

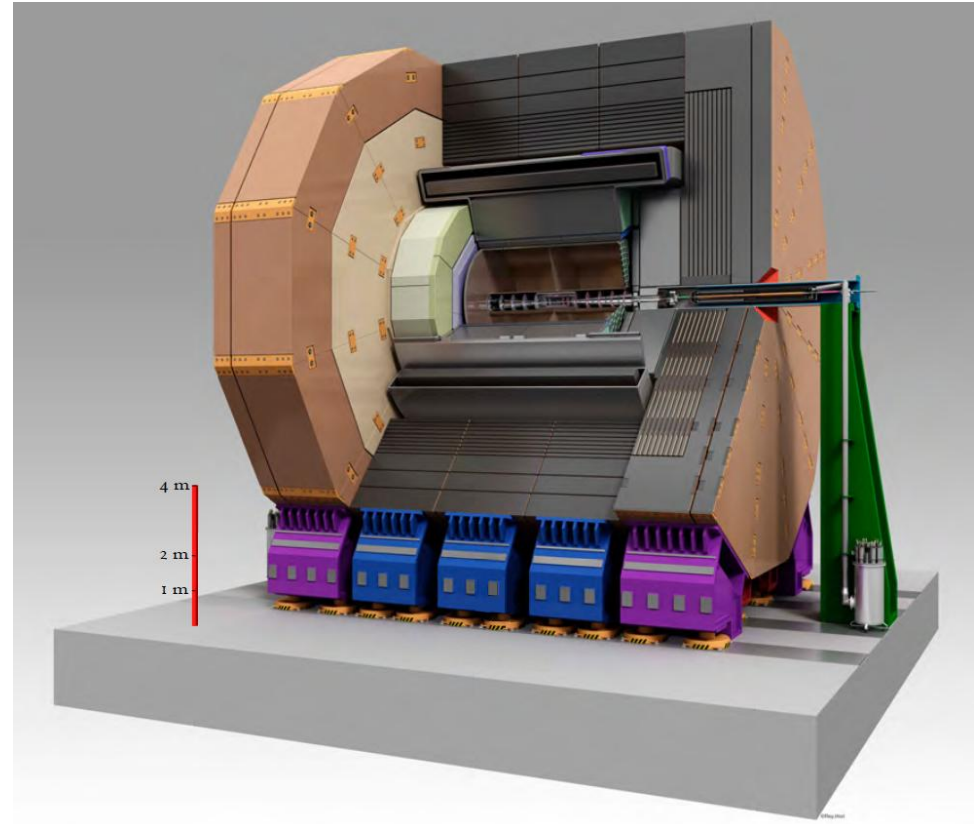

A multi-purpose detector concept



Ties Behnke

Presentation to the IFIC Valencia FCCee open day meeting

16.4.2026

ILD: a detector for precision

Detector Requirements

- Impact parameter resolution $\sigma(d_0) < 5 \oplus 10 / (p[\text{GeV}] \sin^{3/2}\theta) \mu\text{m}$ ~ LHC / 2
- Transverse momentum resolution $\sigma(1/p_T) = 2 \times 10^{-5} \text{ GeV}^{-1} \oplus 1 \times 10^{-3} / (p_T \sin^{1/2}\theta)$ ~ LHC / 10
- Jet energy resolution 3-4% (around $E_{\text{jet}} \sim 100 \text{ GeV}$) ~ LHC / 2
- Hermeticity $\theta_{\text{min}} = 5 \text{ mrad}$ ~ LHC / 3

Physics Studies

- $H \rightarrow bb, cc, \tau\tau$
- Total $\sigma(e+e \rightarrow ZH)$
- $Z/W/H \rightarrow jj$; $H \rightarrow \text{invisible}$
- $H \rightarrow \text{invisible}$; BSM

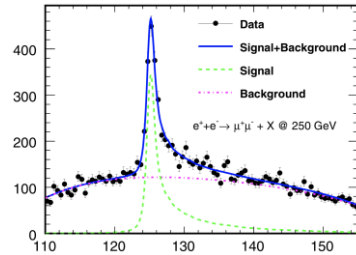
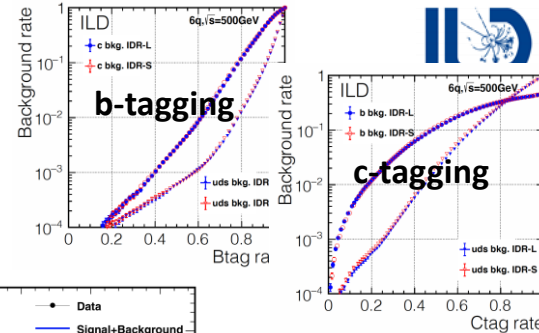

Higgs recoil against $Z \rightarrow \mu\mu$

[arXiv:2003.01116](https://arxiv.org/abs/2003.01116)

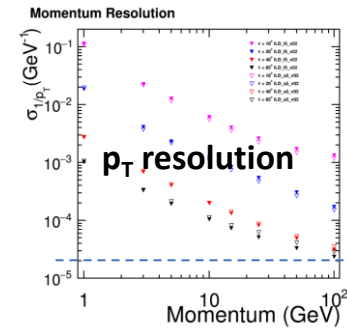

p_T resolution

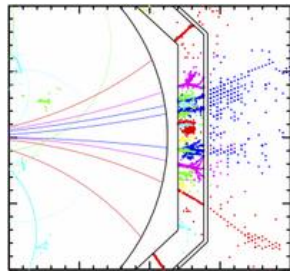

ILD is optimized around **particle flow**:

- Highly granular calorimeters
 - Low-mass trackers
 - Highly detailed software reconstruction
- Separation of clusters at particle level

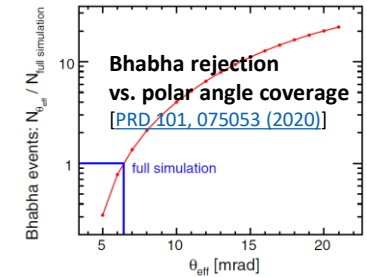
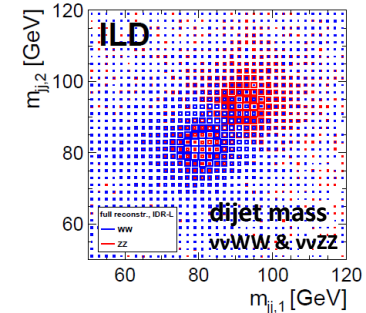

ILD overall design

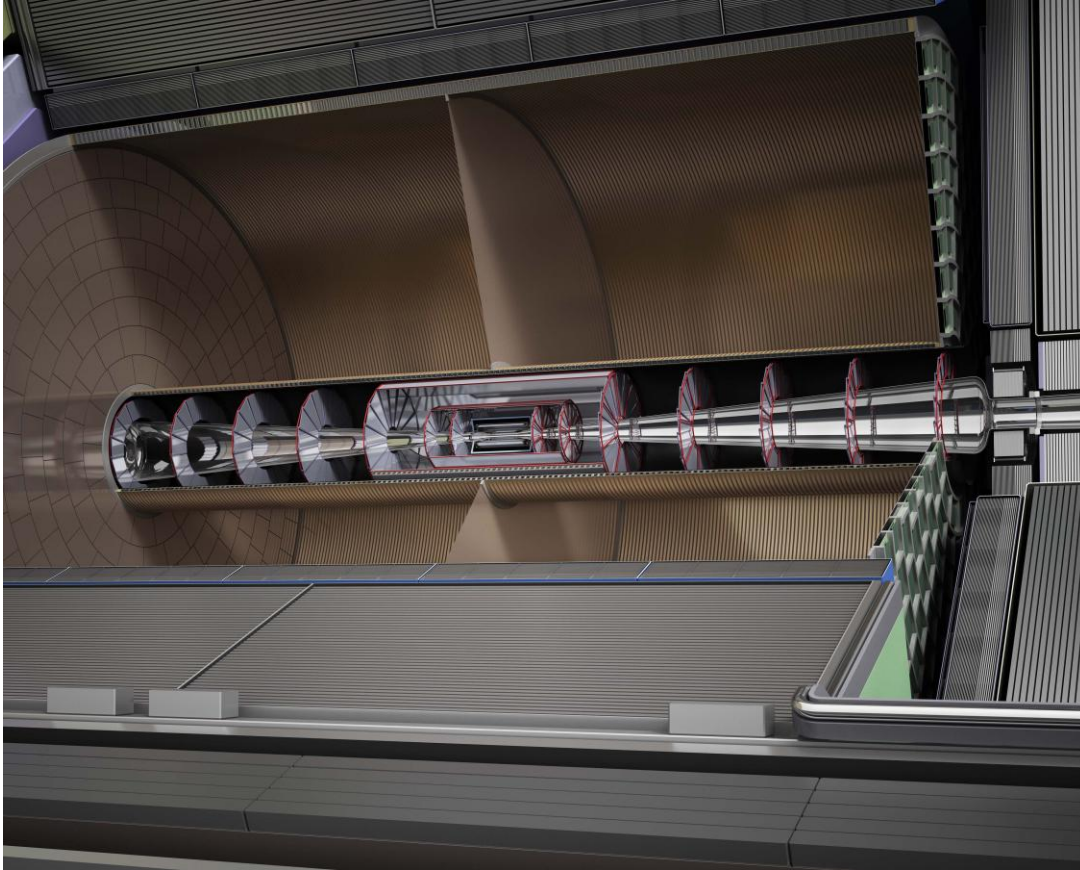

- Powerful inner detector system:
 - Hybrid Silicon- TPC tracking
 - Inner and outer Si system
 - High precision low mass silicon system
- Highly granular calorimeter
 - ECAL: Si-W sampling
 - HCAL: Scintillator or RPC sampling calorimeter

A word on Granularity

A key element of particle flow: granularity across the detector

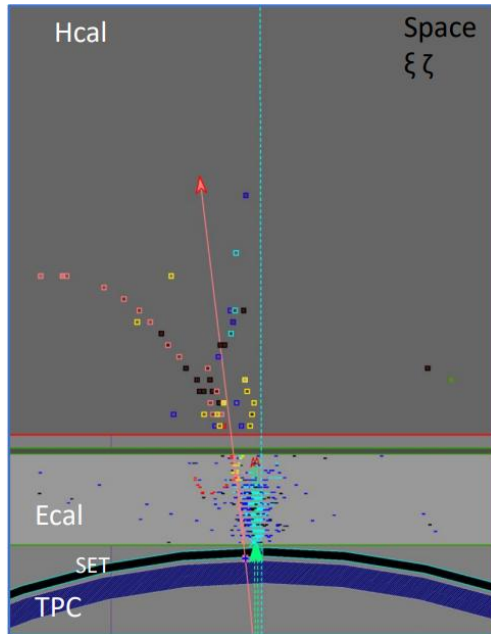

Hits from a hadronic
tau decay in ILD

Particle flow:

- Association of primary partons with detector hits
- Tracking of particle throughout the detector
- Topological information crucial in even reconstruction and event building
- Replace – remove to optimize event resolution

Henri Videau, LLR, ILD event

ILD at FCCee



FCCee has very different bunch pattern compared to a linear collider

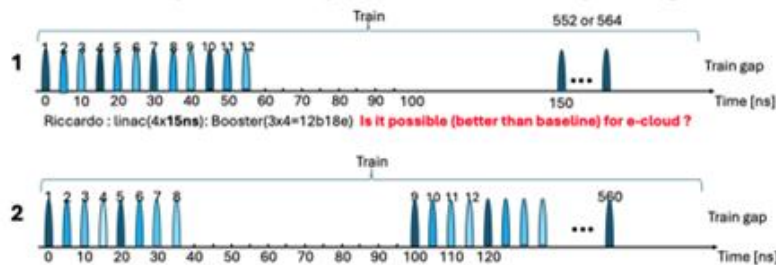

FCCee: trains of bunches every 5 or 50 ns
short inter-train gaps of <200ns

Compare to ILC: trains with bunches
every 175ns, trains at 10 Hz.

FCCee: power pulsing not possible

To ensure excellent science: triggerless readout, continuous sensitivity to events

- At FCCee: will be very challenging, will require probably fast readout and on-detector buffering
- Backgrounds at FCCee are not yet fully understood

ILD@FCC design



Two ILD@FCC versions under study: differ in the design of the inner part.
Inner region needs to be optimized to minimize beam background: this is still a significant challenge for FCCee and no final solution exists (yet)

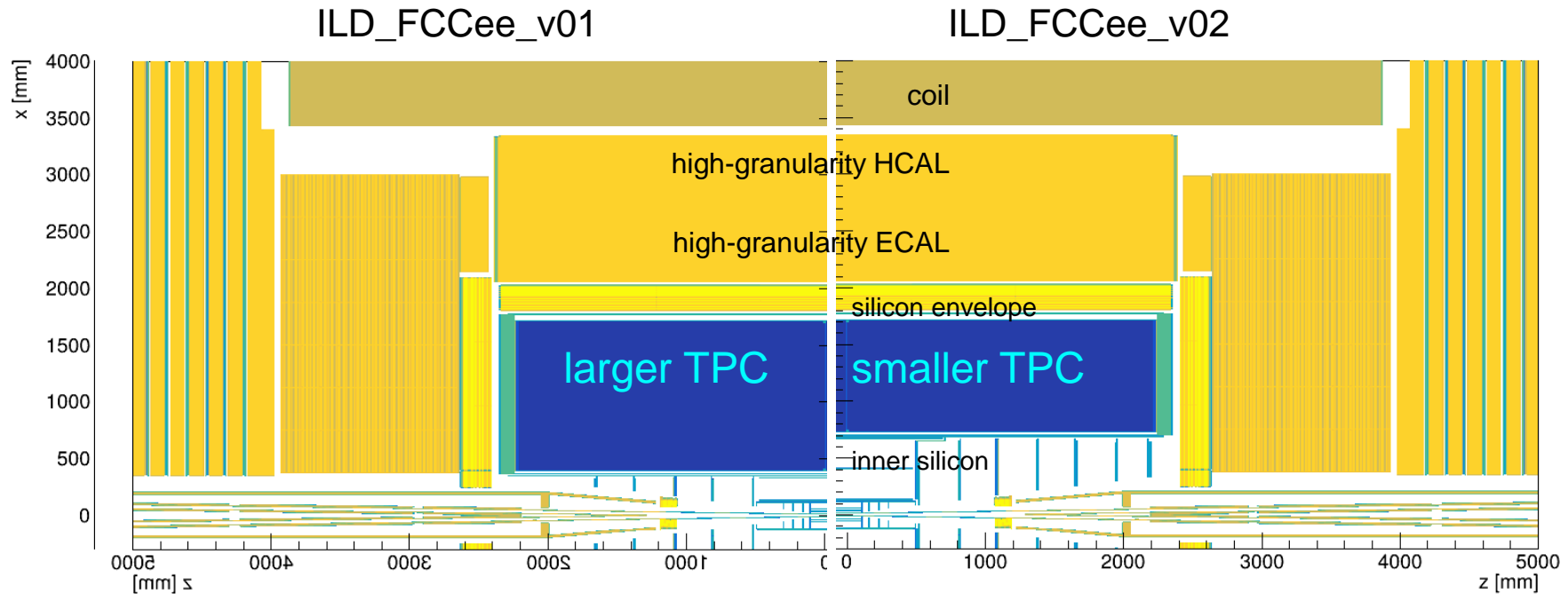

ILD at FCCee and other colliders



- The forward regions are very different – the forward detectors need adapting
The forward region of the ILD detector is under study for a FCC-ee and a HALHF version
- The asymmetric nature of collisions in HALHF will impact the design of ILD in particular in the forward region.
- The different time structure of different colliders impacts the running mode
 - ILC: long inter-bunch space allows power pulsing
 - FCC-ee: quasi CW operation requires active detector cooling and fast front end
- Central tracker: The TPC will see increased backgrounds at a circular machine. It is currently not yet fully demonstrated if a TPC will be able to operate at a Tera-Z factory
- The contributions the TPC can deliver to particle ID in particular at the Z are powerful and make it worthwhile to continue studying this option
- A common challenge is to maintain excellent calibration of the system. Thermal management of the detector will be more challenging for the FCC collider.

Subdetector Status



ILD has a concept of the detector,
well defined
with technological options where sensible

The main components of ILD
have been validated and
beam-tested.

A coherent System design has
been developed.

A complete and detailed
Geant4 model of ILD exists
and is used.

ILD is engaging strongly with the newly
formed DRD detector R&D collaborations.

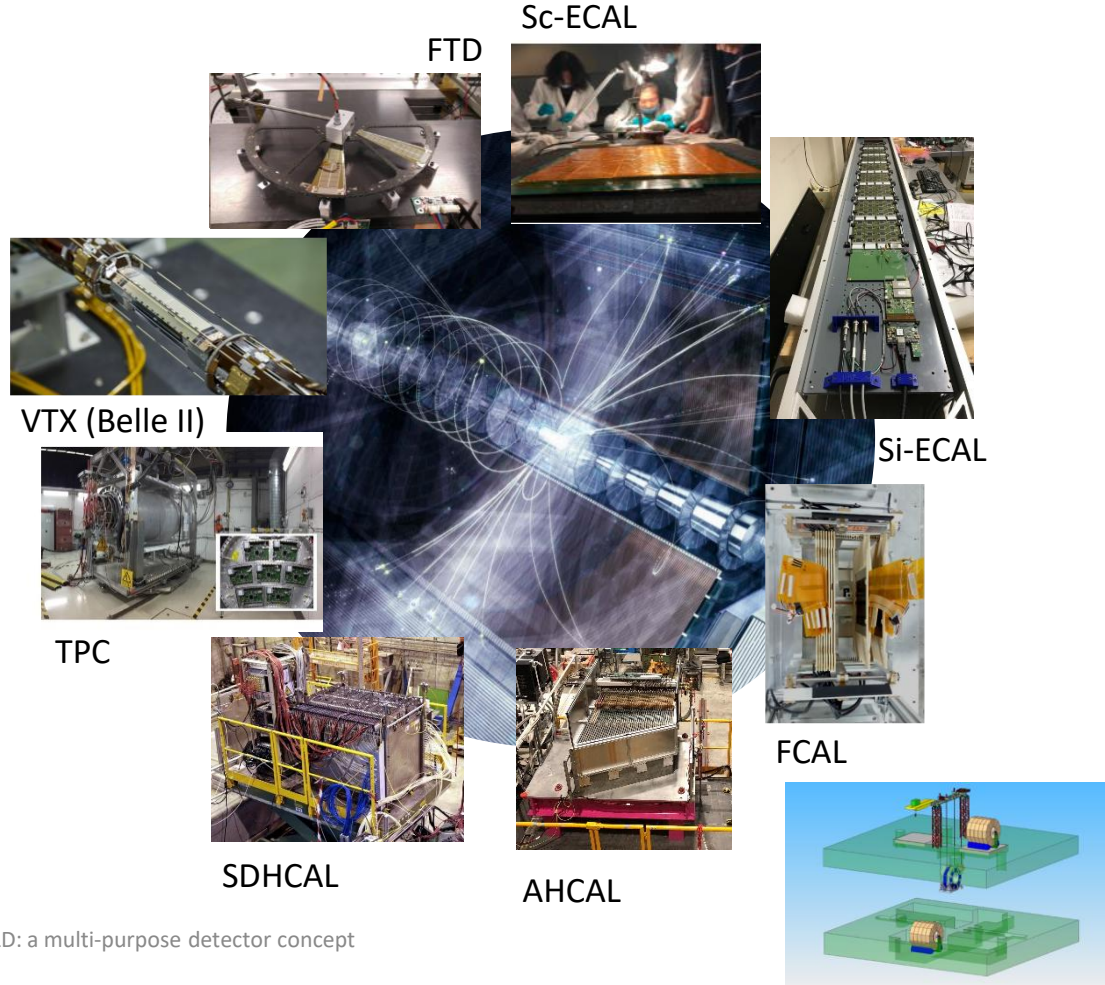

A TPC at a FCC like collider



Several issues

- Inter-bunch spacing much less than at ILC
 - Not a problem
- Occupancy due to physics events and backgrounds
 - Not a problem
- Overall charge buildup in the system
 - problem

Studying the feasibility of a TPC at a FCC-ee remains an issue and requires detailed studies

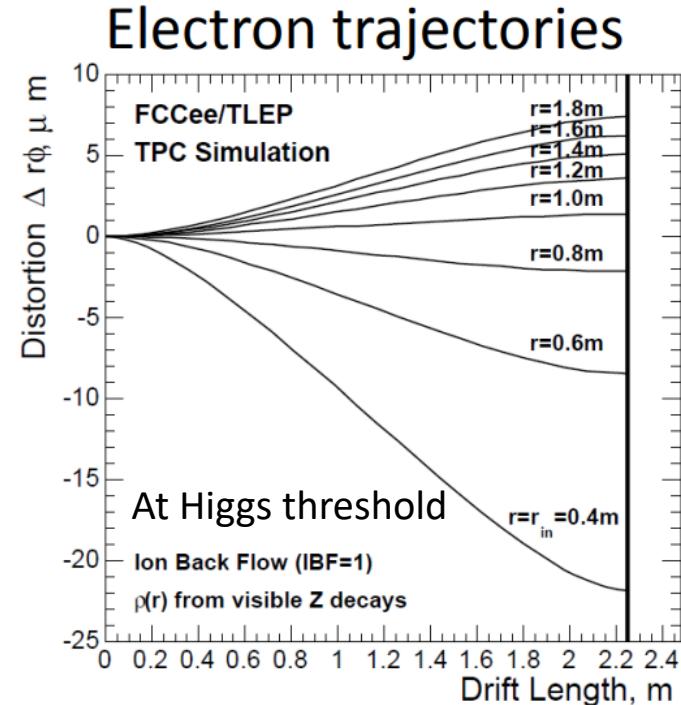

When running on the Z: around factor of 20 worse: max distortions close to 1 mm

The Collaboration



Result of recent membership confirmation:

- 58 institutes confirmed ILC membership
- Around 10 institutes as guests members

institutes per region

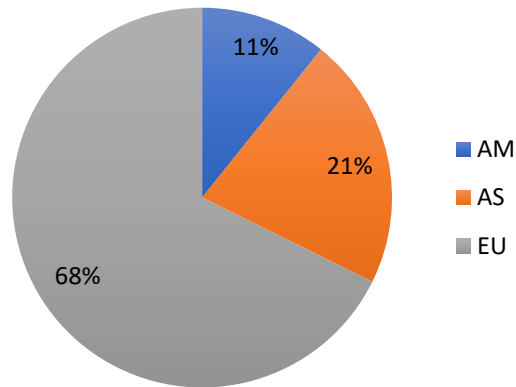

ILD as a group got started around 2008

ILD's roots are linear colliders, ILC in particular but ILC is now engaging strongly with FCCee

ILD's main objective is to develop the best possible experiment for a Higgs/ Electroweak and beyond facility

The next step for ILC is to ensure that ILC is accepted as a proposal for a detector at the FCCee

Spain in ILD



Spanish groups have been part of ILD since its founding with contributions spanning physics studies and detectors developments

Vertex - Forward Tracker – Calorimetry (SiECAL, SDHCAL)
technical coordinator from Spain (Mary Cruz)



UNIVERSITAT DE BARCELONA

SIW-ECAL Layer

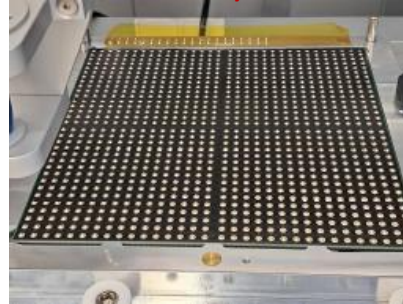

Hybridization @ IFIC lab

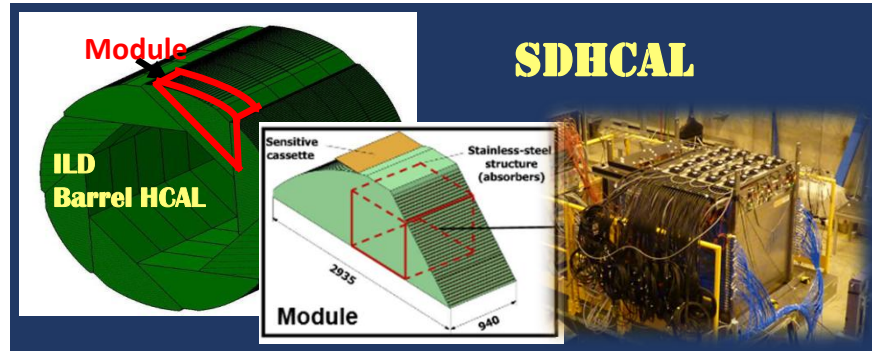

ILD around the world



Memberships of Russian groups is currently suspended

Reality

Prototyping



Published: JINST 10 (2015) P10039



Demonstrating

Engineering

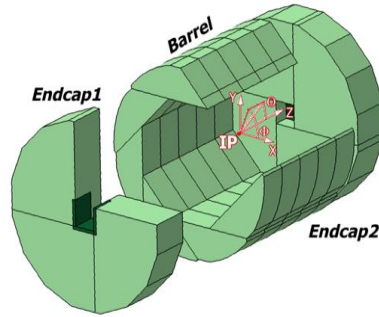

Dt Model
Total Deformation, 6,314e
Type: Total Deformation
Frequency: 6,3905 Hz
Unit: mm

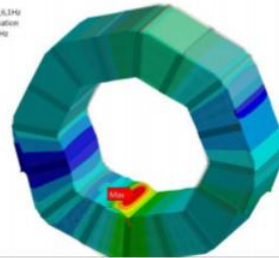
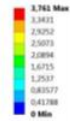

Integration

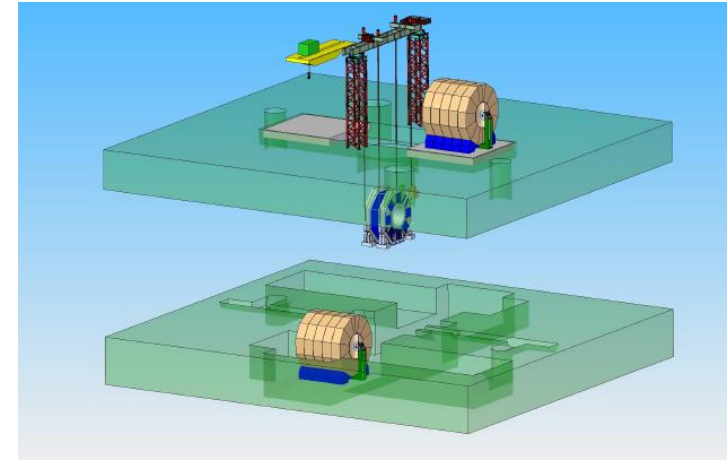

Continued strong effort on analysis in the ILD context;

- Nearly all analyses done in full simulation
- Very active role by ILD in intn'l processes like ESPPU
- Comprehensive list of projects: [ILD collection of projects](#)

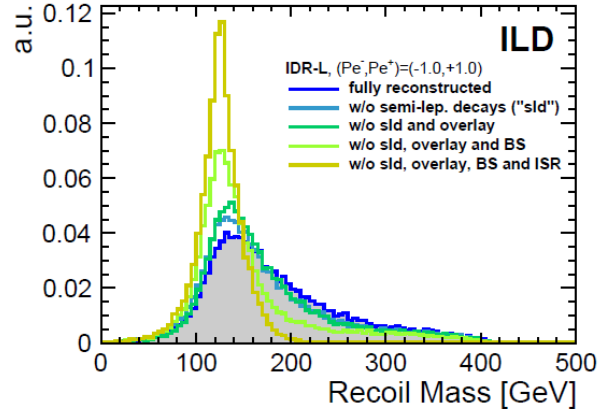

Recoil mass spectrum (invisible Higgs search) for different reconstruction conditions

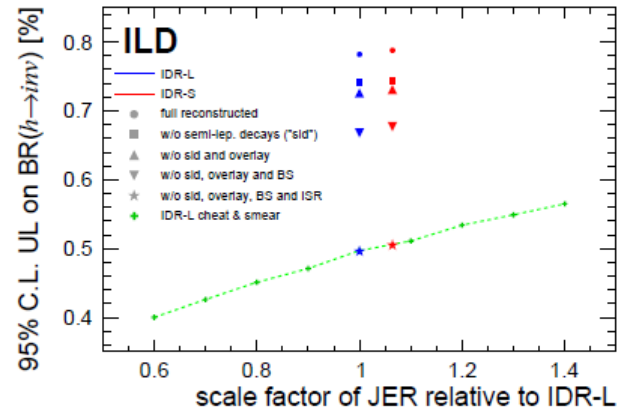

Impact of a detector indicator (JER resolution) on physics observable

ILD and Software



ILD has done a lot on the software and reconstruction side:

- We are a central player in pushing community wide software solutions in particular with **iLCSoft** (LCIO, DD4hep, etc) developed over 15 years
- We are deeply engaged already with communities (linear, circular, FCC-hh) to modernize our software stack: **key4hep** (DD4hep, EDM4hep,...)

There is enormous progress out there in the community on computing, computing models, computing implementations, analysis methods and tools:

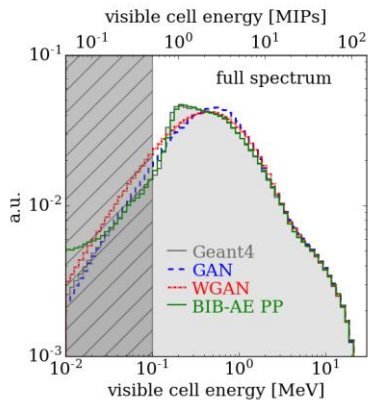

- parallelisation, multi-threading
- GPU based computing
- Machine Learning and AI
- Quantum computing

F. Gaede, E.Eren et al.:
Use of GAN's to simulate
photon showers in the ILD
Calorimeter (2005.05334)

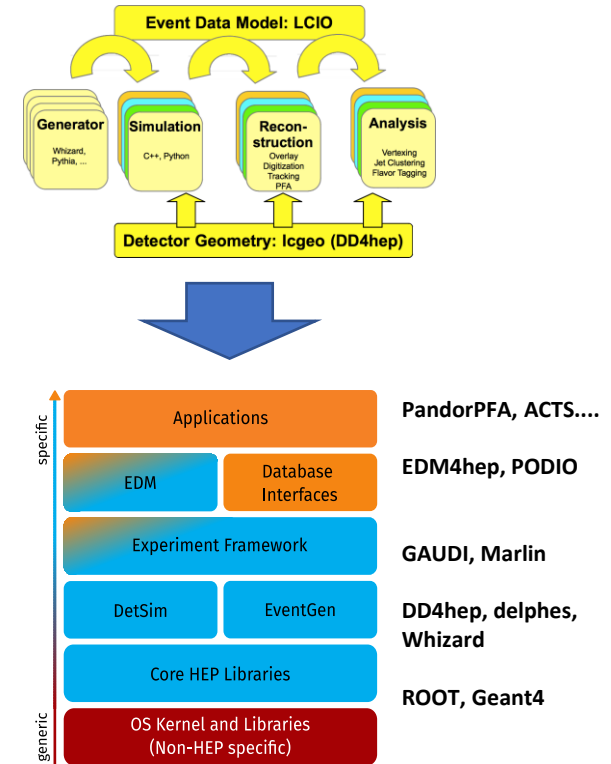

Summary/ Outlook



The ILD group is maintaining and developing a modern particle-flow based detector concept

ILD is continuing to develop the case for a powerful and adaptable detector for a Higgs/ EW/ Top etc factory

ILD is heavily engaged in hardware and in analysis developments

ILD is engaging with FCCee at all levels

ILD is open to anyone who is interested to work with us or to join ILD in a more formal fashion

ILD is maintain presence in discussions for alternative (LCF) or future options like HALHF.