



ALLEGRO

Detector Concept Status

Martin Aleksa (CERN), Nicolas Morange (IJCLab), Marc-Andre Pleier (BNL)

- What is ALLEGRO – Some History
- The ALLEGRO Full Detector Concept Expression of Interest
- ALLEGRO Detector Contacts and their Roles
- ALLEGRO ECAL & HCAL (DRDCalo WP2 & WP3)
- FCC SW Implementation
- Next Steps

What is ALLEGRO?

- **It started with a noble-liquid calorimeter for future experiments**
 - In 2015 started to think about a noble-liquid ECAL for FCC-hh
 - Became part of the FCC-hh reference detector → CDR in 2019, input to the last Update of the European Strategy (ESU)
 - [CDR](#), FCC-hh calorimeter ([arxiv:1912.09962](#)), FCC-hh reference detector: [CERN Yellow Report](#)
- **After 2020 ESU focus shifted to FCC-ee**
 - We adapted noble-liquid ECAL to work in a lepton collider experiment, performance studies showed that it is very competitive compared to other proposals (Si/W, dual read-out calorimetry) - (see [arxiv:2109.00391](#))
 - Noble-liquid calorimetry became work-package inside [CERN EP R&D](#) and later part of DRDCalo as WP2 ([link](#))
- **In 2022 proposed a detector concept based on noble-liquid ECAL**
 - Implemented a version into FCC SW which consisted of a noble-liquid ECAL and some “reasonable” choices for the other sub-detectors. Different choices can easily be tried due to the modularity of the FCC SW. Close collaboration with Sci/Fe HCAL (TileCal) from FCC-hh days
 - Presented detector concept during [FCC Weeks](#), FCC PED Workshops and conferences → triggered interest
 - In 2023 survey to find a name → **ALLEGRO** (**A** Lepton Lepton collider Experiment with **G**ranular **R**ead-**O**ut) was born
- **Current situation**
 - **Strong noble-liquid ECAL team** collaborating within **DRD6 WP2** ([link](#))
 - **ALLEGRO kick-off meeting** in Nov. 2024 ([link](#))
 - **Expressions of Interest (Eoi) for Full Detector Concept submitted to 2025/26 European Strategy for Particle Physics Update** ([link](#))
 - **Call for sub-detector contact persons** issued in summer. all contact persons **identified and announced** end 2025.

→ A detector concept in its very beginnings

Eol for Full Detector Concept

Sub-Detector	Institutes
Vertex Det. and MDI Region	ETH Zurich (CH), Univ. of Zurich (CH), PSI (CH), BNL (US), INFN Pisa (IT), INFN Frascati (IT), IPHC (FR), CPPM (FR), LPNHE (FR), APC (FR), IP2I (FR)
Tracker	Univ. of Michigan (US), MPP Munich (DE), BNL (US), UT Austin (US), IJCLab (FR), EPFL (CH)
Timing Layer	Univ. of Zurich (CH), PSI (CH), BNL (US), CEA-Irfu (FR), IP2I Lyon (FR)
Electromagnetic Calorimeter	CERN, APC (FR), IJCLab (FR), CPPM (FR), OMEGA (FR), LAPP (FR), MPP Munich (DE), TU Dresden (DE), BNL (US), Brown Univ. (US), NYU (US), Columbia Univ. (US), SMU (US), Univ. of Arizona (US), UT Austin (US), Stony Brook (US), Charles Univ. (CZ), IFIN-HH and UPB (RO), IEP SAS Kosice (SK)
Solenoid and Cryostat	CERN
Hadronic Calorimeter	ITIM Cluj Napoca (RO), LIP (PT), IFIC Valencia (ES), Bergen (NO), FZU (CZ), Charles Uni (CZ), Tbilisi (GE), CERN
Muon System	MPP Munich (DE), Weizmann Institute (IL), Univ. of Napoli (IT), Rome 1 (IT), Rome 3 (IT), Univ. of Michigan (US)
Luminosity Calorimeter	Univ. of Geneva (CH), Univ. of Zurich (CH), Univ. of Copenhagen (DK)
Read-Out and Trigger	CERN, Univ. of Geneva (CH), HEPIA (CH), Univ. of Zurich (CH), ZHAW (CH), MPP Munich (DE)
Software and Simulation	CERN, APC (FR), IJCLab (FR), LAPP (FR), UT Austin (US), B.K.C College (IN)

- **Eol for full detector concept** submitted to the European Strategy for Particle Physics 2025/26 ([link](#))
 - **170 authors from 47 institutes**
- **Most of these groups** have also **submitted Eol's for sub-detectors** ([link](#)) and are working together within the framework of **DRDs**

Expression of Interest for the ALLEGRO Full-Detector Concept for FCC-ee

M. Aleksa,¹ N. Morange,² M.-A. Pleier,³ G. Aad,⁴ T.K. Aarrestad,⁵ R. Aleksan,⁶ M. Alvigi,^{7,8} T. Andeen,⁹ J. Andrea,¹⁰ F. Anulli,^{11,12} F. Aretio-Zarate,¹ O. Arnez,¹³ H. Arnold,¹⁴ N.A. Asbah,¹⁵ M. Backhaus,¹⁶ M. Barbero,¹⁷ T. Barillari,¹⁸ J. Baudot,¹⁹ H.P. Beck,²⁰ G. Bernardi,²¹ A. Besson,²² M. Biglietti,¹⁸ F. Blanc,¹⁹ M. Bomben,¹⁷ M. Boscolo,²⁰ G. Boudoul,²¹ S. Bressler,²² G. Calderini,²³ L. Caminada,^{24,25} F. Canelli,²⁶ G. Charles,² A. Chaudhuri,²⁶ H. Chen,²⁷ R. Chiche,² D. Cleri,¹ D. Contardo,²⁸ M. Corradi,^{11,12} T. Dai,²⁹ M. Dam,²⁸ R. De Asmundis,⁹ A. Deiana,²⁹ M. Della Pietra,^{7,8} M. Delmastro,¹³ G. Deputch,³ K. Dewyspelerae,¹⁷ C. Di Donato,⁸ B. Di Micco,¹⁸ R. Di Nardo,¹⁸ F. Djama,⁴ M. Donega,³ A. Durglishvili,³⁰ G. Eigen,³¹ Z. El Bitar,¹⁹ W. Erdmann,²⁵ F. Fallavollita,¹³ J. Faltova,³² L. Felgion,⁴ L. Fiorini,³³ D. Fournier,² B. Francois,¹ J. Fried,³ N. Gallice,³ S. Gao,³ C. Gargiulo,¹ J. Ge,²⁷ V. Gkoukousis,²⁴ T. Golling,³⁴ L. Guan,²⁷ Y. Guo,²⁷ G. Haefeli,¹⁹ M. Haviernik,³² C. Herwig,²⁷ M. Himmelsbach,⁷ Z. Huang,⁷ G. Iakovidis,³ P. Iengo,^{7,8} A. Ilg,²⁴ M. Iodice,¹⁸ M. Kado,¹⁵ P. Karst,⁴ B. Kilminster,²⁴ A. Kiryunin,¹⁵ S. Kluth,¹⁵ P. Kontaxakis,³⁴ M. Koppitz,^{1,35} O. Kortner,¹⁵ S. Kortner,¹⁵ B. Korzh,²⁴ A. Koulouris,¹ H. Kroha,¹⁵ C. Lange,²⁵ S. Leontsinis,²⁴ T. Li,¹⁷ C. Li,²⁷ T. Loeliger,³⁶ C. Luci,^{11,12} A. Macchiolo,²⁴ A. Maloizel,¹⁷ R. Marchevski,¹⁹ G. Marchiori,¹⁷ J. Maurer,³⁷ S. Menke,¹⁵ M. Mentink,¹ O. Mezhzenska,³⁸ M. Mlynarikova,¹ S. Moberg,¹⁶ S. Molina,¹ E. Monnier,³ P. Mukim,³ K. Nelson,²⁷ N. Nikiforov,¹ R. Nisius,¹⁵ P. Onyisi,⁹ P. Owen,²⁴ F. Palla,^{39,1} T.H. Park,¹⁵ J. Parsons,⁴⁰ R. Pedro,⁴¹ J. Pekkanen,⁹ E. Petit,⁴ F. Petrucci,¹⁸ I. Polak,⁴² G. Popeneciu,⁴³ G. Proto,¹⁵ C. Prutti,^{11,1} J. Qian,²⁷ V. Radeka,³ B. Ravina,¹ S. Rescia,³ R. Richter,¹⁵ S. Rosati,¹² J. Rutherford,⁴⁴ E. Salzer,²⁷ P. Schacht,¹⁵ S. Schramm,²⁴ T. Schwarz,²⁷ P. Schwemling,⁵ G. Sekhniaidze,⁸ S. Senyukov,¹⁹ N. Serra,²⁴ A. Sfyria,³⁴ L. Shchutska,¹⁹ R. Simionello,¹ S. Snyder,³ O. Solovyanov,⁴⁵ F. Sopkova,³² P. Strizenev,³⁸ G. Suliman,⁴⁶ C. Suslu,²⁷ G. Tarna,³⁷ A. Tricoli,³ V. Tudorache,³⁷ A. Upegui,⁴⁷ R. Van, ^{12,12} E. Varnes,⁴⁴ S. Veneziano,^{11,12} A. Verbitskiy,¹⁵ E. Voevodina,¹⁹ R. Wallny,⁵ C. Wang,⁹ C. Weaverdyck,²⁷ M. Weber,¹⁶ T. Wengler,¹ H. Wilkens,¹ Z. Wu,¹⁵ B. Yu,³ C. Zhang,³ M. Zhao,³ B. Zhou,²⁷ and J. Zhu.²⁷

Eol's for sub-detectors

Sub-Detector	EoI IDs
Vertex Det. and MDI Region	ID0019, ID0027, ID0036, ID0047, ID0069, ID0088, ID0105
Tracker	ID0015, ID0024, ID0043, ID0061, ID0080, ID0085, ID0098, ID0099
Timing Layer	ID0080, ID0096, ID0098, ID0099
Electromagnetic Calorimeter	ID0023, ID0031, ID0064, ID0067, ID0082
Solenoid and Cryostat	
Hadronic Calorimeter	ID0086
Muon System	ID0011, ID0016, ID0037, ID0049, ID0060, ID0069, ID0078, ID0084
Luminosity Calorimeter	ID0104
Read-Out and Trigger	ID0017, ID0092, ID0103

<https://indico.cern.ch/event/1439855/contributions/6461614/>

FCC Detector Concepts Work Package

In DRDs:

RnD / technologies

- Gaseous Detectors (DRD1)
- Liquid Detectors (DRD2)
- Semiconductor Detectors (DRD3)
- Photodetectors & PID (DRD4)
- Quantum Sensors (DRD5)
- Calorimetry (DRD6)
- Electronics (DRD7)
- Mechanics (DRD8)

US R&D Collaborations (RDCs) focus on generic (non-targeted), interdisciplinary and blue sky R&D – will collaborate where possible.

In FCC Detector concepts:

a) Generic system-level studies (create structure as needed or organize workshops)

- Tracker (e.g. Si + straw tracker) & PID
- Calorimetry
- Muons
- TDAQ
- Luminometry
- Magnet

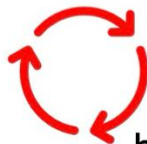

b) Concept-specific studies (using specific envelopes/support structures, or physics benchmarks)

- **Allegro**
- CLD
- IDEA
- ILD
- ...

Non-exclusive membership, need to preserve synergies and unity of the community!

Evolution of FCC Detector Concepts Work Package, Dec. 2025 ([link](#))

ALLEGRO Detector Contacts

Sub-Detector	Detector Contact
Vertex Det. and MDI Region	Oliver Kortner (MPP Munich)
Tracker	
Timing Layer	
Electromagnetic Calorimeter	Nicolas Morange (IJCLab)
Solenoid and Cryostat	
Hadronic Calorimeter	Henric Wilkens (CERN)
Muon System	Jianming Qian (U. of Mich.) & Paolo Iengo (U. of Napoli)
Luminosity Calorimeter	
Read-Out and Trigger	Steven Schramm (U. of Geneva) & Thorsten Wengler (CERN)
Software and Simulation	

- **Call for nominations sent in July 2025**
- Received many nominations
- **Candidates chosen and contacted** during Sept. – Oct., all of them **accepted** until Nov. (see list on the left)
- **Role of contact persons:**
 - **Oversee the progress in their respective field**
 - **Coordinate ALLEGRO-specific aspects in their respective field**
 - **Act as contacts to the FCC PED generic system-level studies groups/meetings**
 - **ALLEGRO-specific sub-system meetings** will be organized to discuss ALLEGRO-specific aspects (see next slide) – those meetings are of course open to everybody!

ALLEGRO Detector Concept



ALLEGRO

A Lepton Lepton collider Experiment with Granular Read-Out

Vertex Detector

Tracking

Silicon Wrapper + ToF

High Granularity ECAL

- Excellent resolution, linearity, stability
- Optimised for particle flow
- Noble-liquid as active material

Solenoid $B=2T$ (study option to go $B>2T$ for c.o.m. energies $> Z$ -pole), sharing cryostat with ECAL, between ECAL and HCAL

- Light solenoid coil $\approx 0.76 X_0$
- Low-material cryostat $< 0.1 X_0$

High Granularity HCAL (Iron Yoke?)

Muon System (Iron Yoke?)

First introduced at [FCC Week 2022](#) in Paris ([link to talk](#))

ALLEGRO ECAL – The Best of Two Worlds

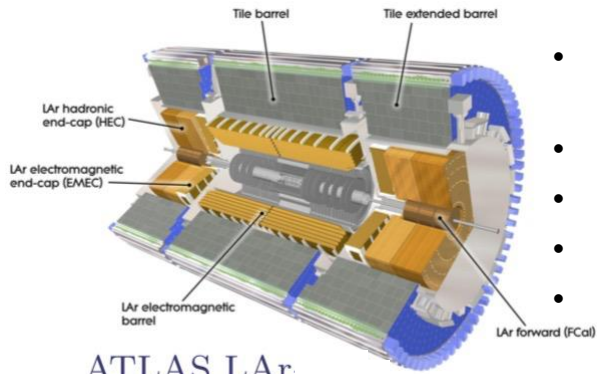

- Good intrinsic energy resolution
- Radiation hardness
- High stability
- Linearity and uniformity
- Easy to calibrate

ATLAS LAr

arXiv:1305.4551

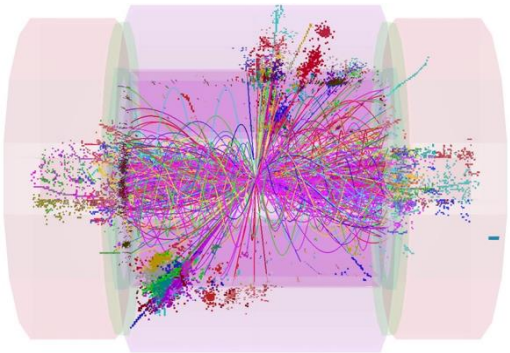

CLIC Detector

- High granularity
 - Pile-up rejection
 - Particle flow
 - Particle ID,
 - Tracking inside Calo
 - 3D/4D/5D imaging

FCC Calorimetry

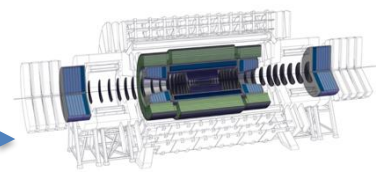

FCC-hh
[CERN Yellow Report](#)

FCC-ee



DRDCalo WP2 & WP3

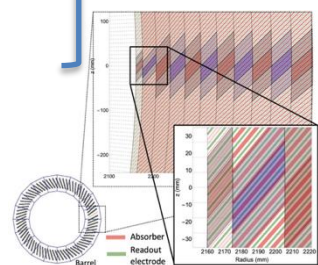

Highly Granular Noble-Liquid Calorimeter (DRDCalo WP2)

Developed in the framework of DRDCalo WP2

Baseline design

- 1536 straight inclined (50.4°) 1.8mm Pb absorber plates
- $R_i=216\text{cm}$, $R_o=256\text{cm}$ (small adjustments possible/probable)
- Multi-layer PCBs as readout electrodes
- 1.2 – 2.4mm LAr gaps
- 40cm deep ($\approx 22 X_0$)
- Segmentation:
 - $\Delta\theta = 10$ (2.5) mrad for regular (1st comp. strip) cells,
 - $\Delta\phi = 8$ mrad
 - \rightarrow cell size in strips: 5.4mm x 17.8mm x 30mm
- 11 longitudinal compartments
- Implemented in FCC-SW Fullsim
- Exact radius and lateral and longitudinal segmentation subject to further optimization!

Possible Options

- LKr or LAr, W or Pb absorbers,
- Absorbers with growing thickness
- Granularity optimization
- Al or carbon fibre cryostat
- Warm or cold electronics

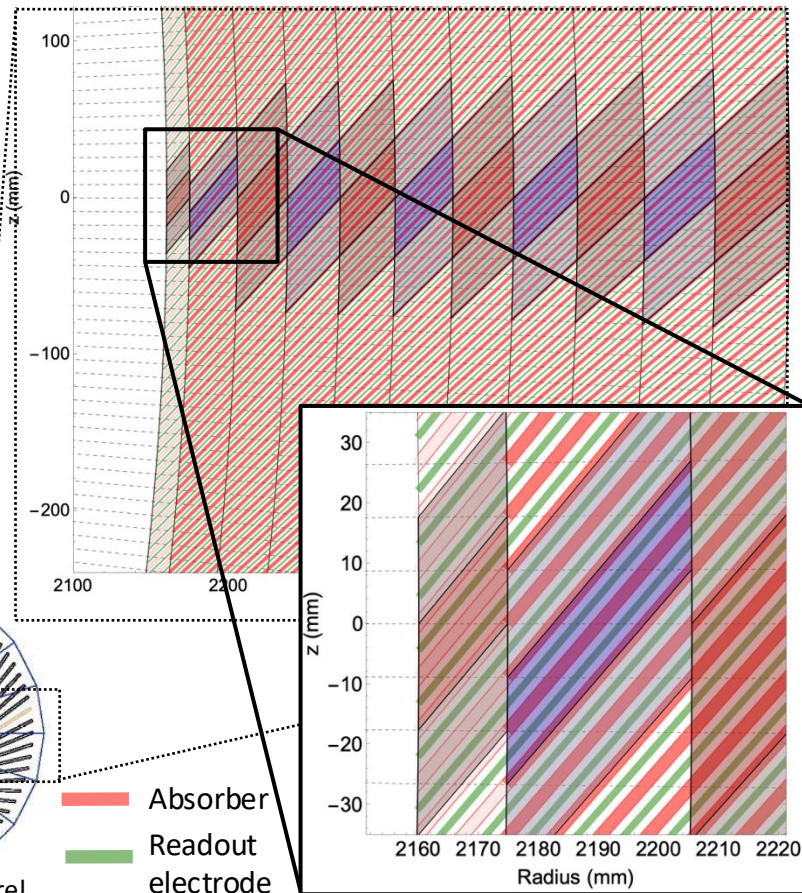
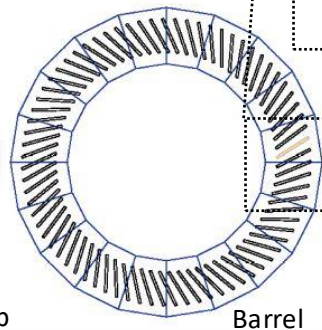
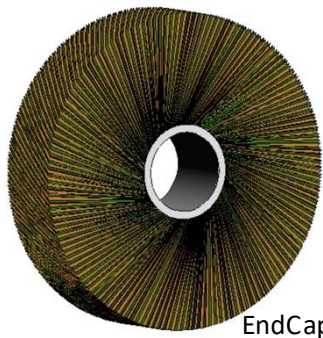

Challenges: Resolution, Noise and Crosstalk

- **EM resolution** with sampling term of 7% – 9%
- **Noise vs cross-talk challenge:** traces need to be shielded to minimize cross-talk → grounded shields increase detector capacitance and hence noise → need to find best compromise – **several prototype electrodes produced & measured**
 - **Noise** of < 1.5 MeV per cell for **warm electronics** and transmission lines of $R_0 = 100 \Omega$ and $\tau = 200 \text{ ns}$ ($C_d \leq 250 \text{ pF}$)
 - → MIP S/N > 5 reached for all layers
 - **Noise** factor 5 less for **cold electronics**
 - **Cross-talk** of < 1% for shaping times $\tau \geq 20 \text{ ns}$
- **Next steps: Further optimization, then ≈64 absorber test module for testbeam**

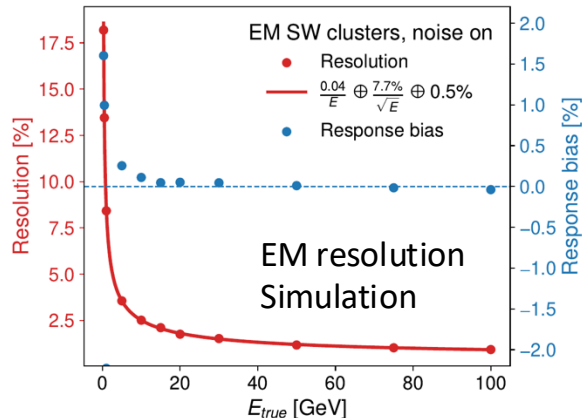
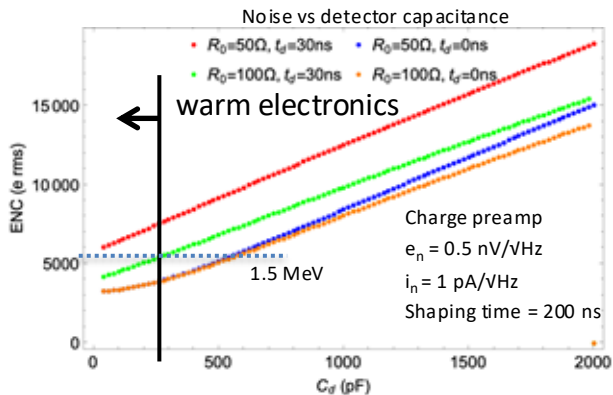

Simulated cross-talk 2 shields < 1% for $\tau \geq 20 \text{ ns}$ confirmed by measurements on prototype

Cross-talk (%)	Cell 1	Cell 2	Cell 3	Cell 4	Cell 5	Cell 6
Shaping time (ns) ↓						
No shaper	0.54	0.85	0.85	2.31	2.62	9.11
20	0.03	0.04	0.01	0.09	0.11	0.75
50	0.01	0.02	0.0	0.04	0.05	0.37
100	0.01	0.01	0.0	0.02	0.03	0.23
150	0.0	0.01	0.0	0.02	0.02	0.18
200	0.0	0.01	0.0	0.01	0.02	0.15
300	0.0	0.0	0.0	0.01	0.01	0.13

Recent Progress ALLEGRO ECAL (DRDCaIo WP2)

See [talk by Zuchen Huang](#) on Thursday

- **Electrodes:**
 - Large-scale prototypes built with many design options (different shieldings of signal traces)
 - → Sub-per-mille level cross-talk achievable
 - Good agreement with FEM simulations
 - **High Voltage (HV)** test on-going
- **Cold electronics:**
 - CHARMS250: further development of Dune electronics
 - CALOROC1C: On-going development at OMEGA
- **Absorbers:**
 - 1.8mm lead plates, sandwiched between stainless steel, sheets, glued by prepreg
- **Cryostat (carbon fibre):**
 - Wall thickness down to few % per wall
 - First prototypes built, now planning for 1m³ prototype

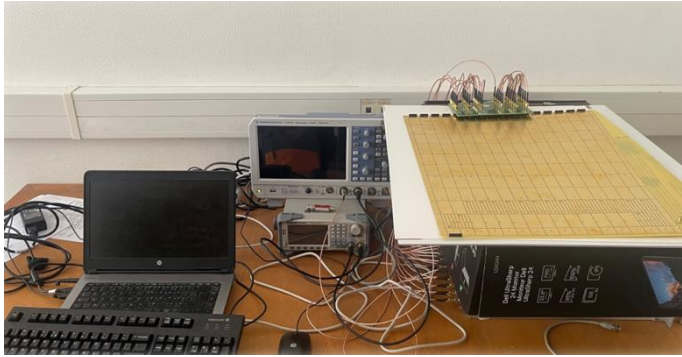

Electrode test set-up

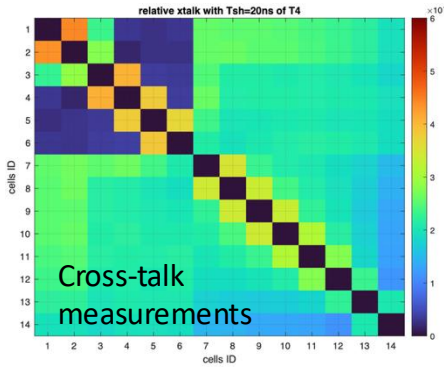

Cross-talk measurements



Carbon fibre wall for cryostat



Absorber cold test

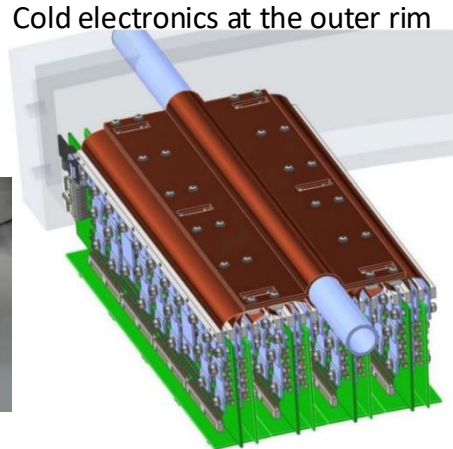

Highly Granular HCAL for ALLEGRO (DRDCalo WP3)

- Developed in the framework of DRDCalo WP3
- ATLAS TileCal inspired HCAL has been implemented into FullSim, other Sci/Steel options (CALICE like) will also be studied
- FCC-ee TileCal inspired by ATLAS TileCal:
 - 5mm steel absorber plates alternating with 3mm Scint.: 8 - 9.5 λ
 - 128 modules in ϕ , 2 tile/module
 - 13 compartments in depth (in addition to 11 comp. in the ECAL)
 - $\Delta\eta = 0.025$ (grouping 3-4 tiles), $\Delta\phi = 0.025$
 - FCC-ee TileCal geometry is available in FCCDetectors
 - Hardware work started: testing sci tile + WLS fibre + SiPM readout
 - ECAL + HCAL performance: Sampling term of $\sim 35\%$ for $\pi^\pm \rightarrow$ excellent starting point for particle flow reconstruction! \rightarrow further improvement expected

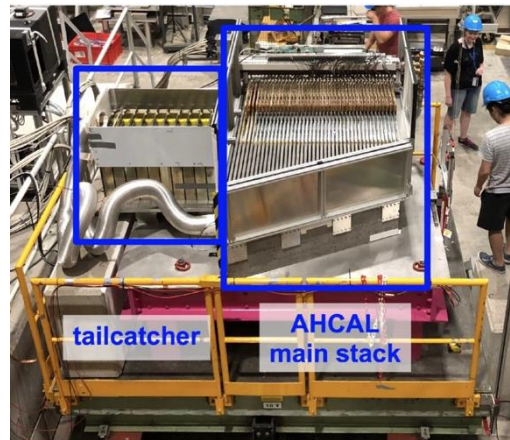

CALICE AHCAL

TileCal

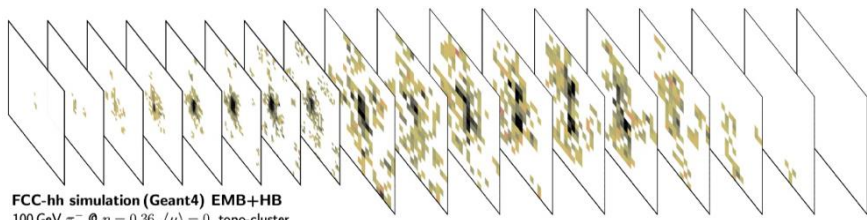

FCC-hh simulation (Geant4) EMB+HB
100 GeV π^- @ $\eta = 0.36$, $(\mu) = 0$, topo-cluster

Example π^- shower FCC-hh

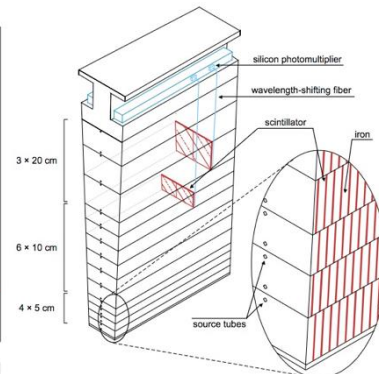
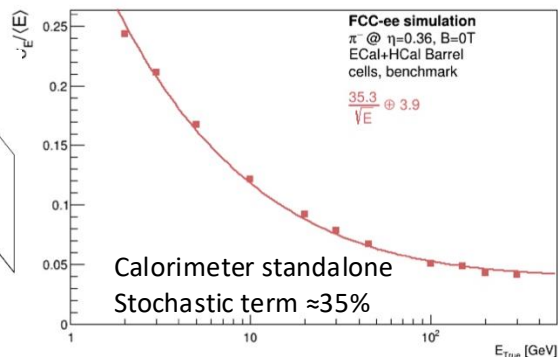

ALLEGRO Detector Concept

From the beginning many different ideas/options → we should stay open for new ideas

Envelopes need to be optimised/adapted to chosen technologies → discussions in meetings of contact persons

At the moment one version was implemented into FCC SW, but all proposed sub-detectors should be implemented into FCC SW.



FCC SW – ALLEGRO Simulation

- **What do we currently have in the ALLEGRO simulation?**
- **Tracking system taken from IDEA 'as is'**
 - Vertex detector with curved sensors (can be made straight)
 - Two versions:
 - One with drift chamber z-extent un-changed (to be optimized)
 - One with straw tube tracker
 - Silicon Wrapper similar to the vertex detector but with planar sensors
- **Flexible Noble Liquid ECAL barrel with inclined absorbers**
 - Baseline: straight Pb+Steel absorber, growing sensitive gap
- **Turbine geometry Noble Liquid ECAL endcaps**
 - First version available
- **TileCal HCAL tuned to FCC-ee (barrel and endcaps)**
- **Muon Tagger as sensitive cylinder/disks**
 - Mainly a place holder

See [talk by Jacopo Fanini](#) at the FCC PED WS
or [talk by Brieuc François](#) at the ALLEGRO ID Meeting

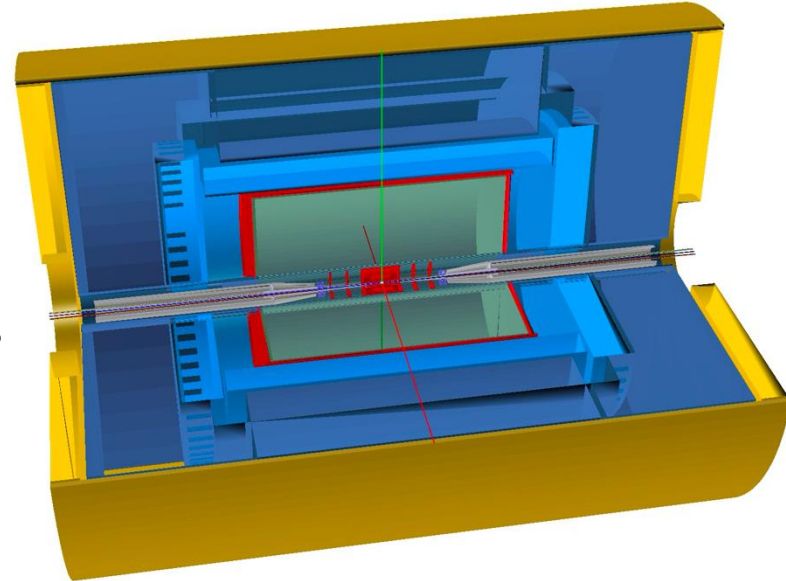

Courtesy Brieuc Francois

ALLEGRO Simulation & Reconstruction

- **ALLEGRO simulation is fully integrated in the Key4hep framework**
 - As for the other FCC detectors (a must to leverage synergies)
 - **Very modular approach** → once your sub-detector is implemented events can be simulated with other ALLEGRO sub-detectors → easy to compare physics performance
- **What is currently available for the ALLEGRO reconstruction**
 - Gaussian smearing based vertex detector, drift chamber / straw tracker and silicon wrapper digitization
 - Generator particle based tracking → realistic tracking solutions under development
 - Fairly detailed calorimeter digitization (calibration, noise, cross-talk)
 - Several calorimeter clusterings: sliding window, topological clustering, CLUE
 - MVA based calibration and theta correction available
 - MVA based π^0 /photon separation algorithm
 - Calo only jet clustering
 - Particle-flow object (PFO) reconstruction with PandoraPFAis and ML-PFlow under development

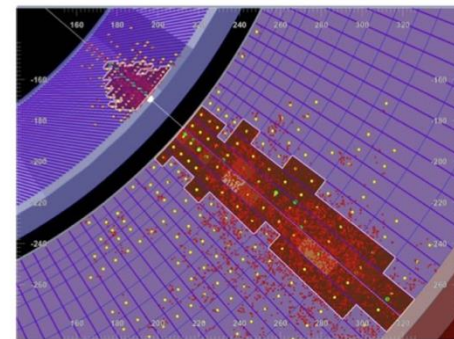

*clustering in ECAL (and HCAL) barrels
now working on endcap clustering*

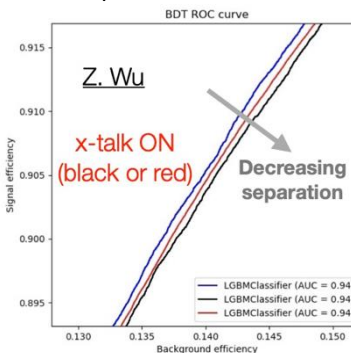
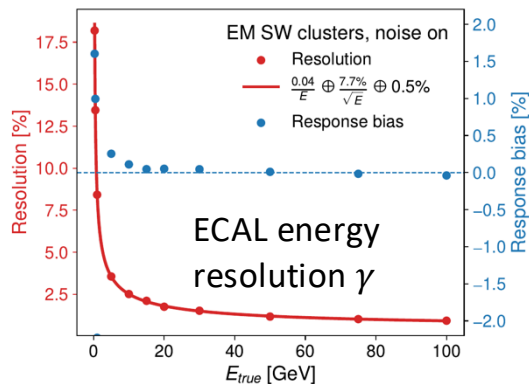
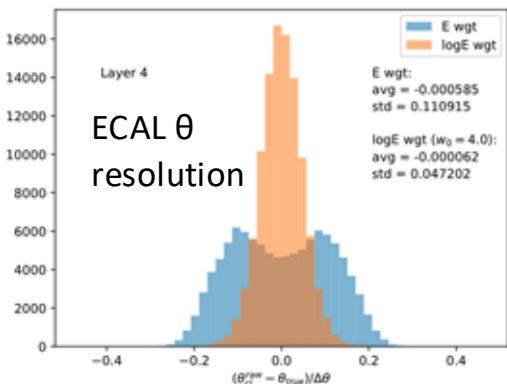

photon/pi0 discrimination

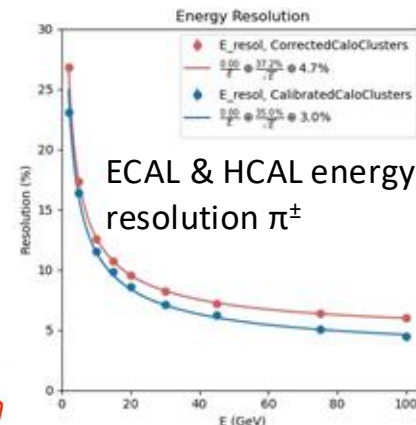

ECAL & HCAL energy resolution π^0

Next Steps – FCC Detector Concepts Group

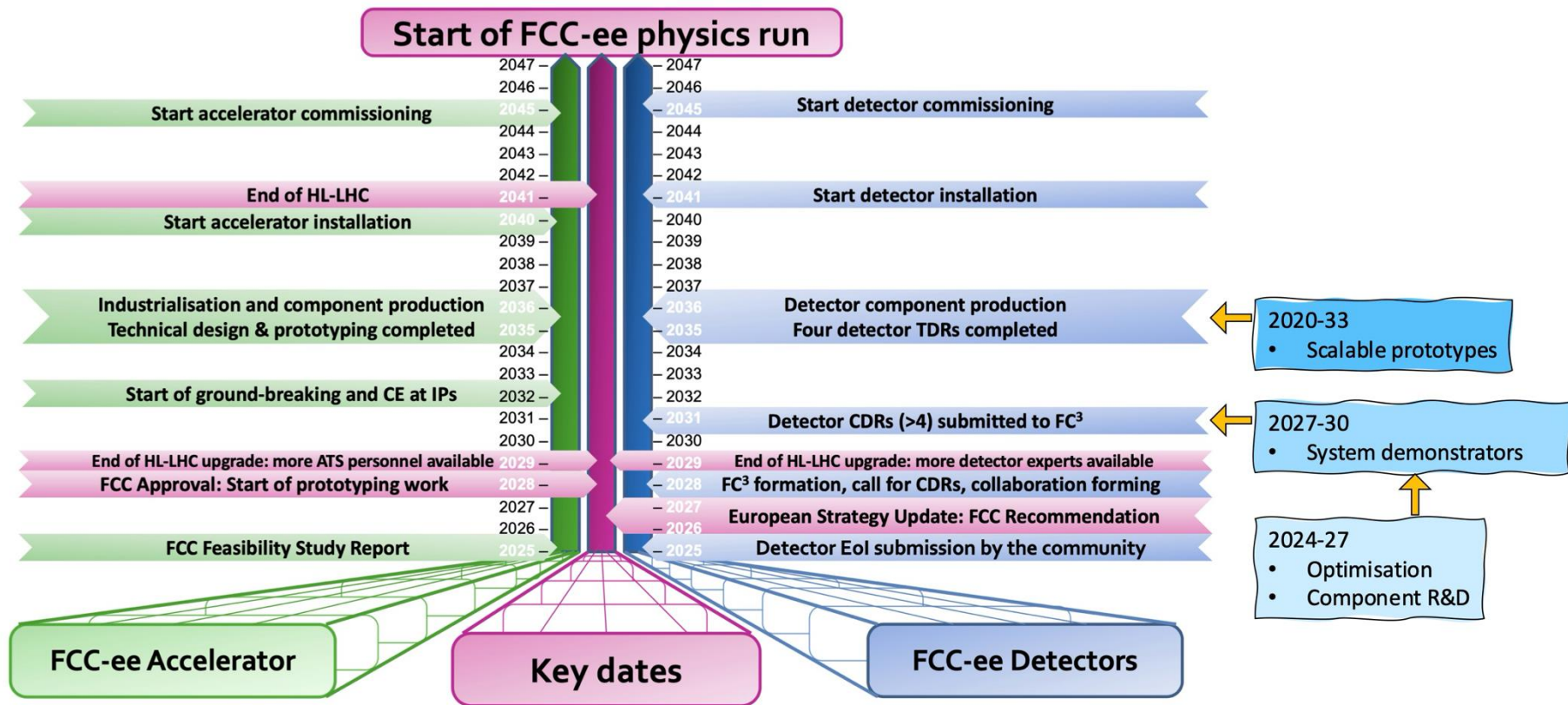

M. Dam, FCC Week 2025

Next Steps – ALLEGRO

- Prepared an EoI for the ALLEGRO full-detector concept for the ongoing European Strategy Update (ESU) in response to the EoI call for full-detector concepts
- We aim to propose ALLEGRO as a high-performance general-purpose detector concept for FCC-ee, that will fulfil all the requirements of its ambitious physics program. While the concept is centred around a noble-liquid based ECAL, the technology choices concerning all other sub-detectors are fully open

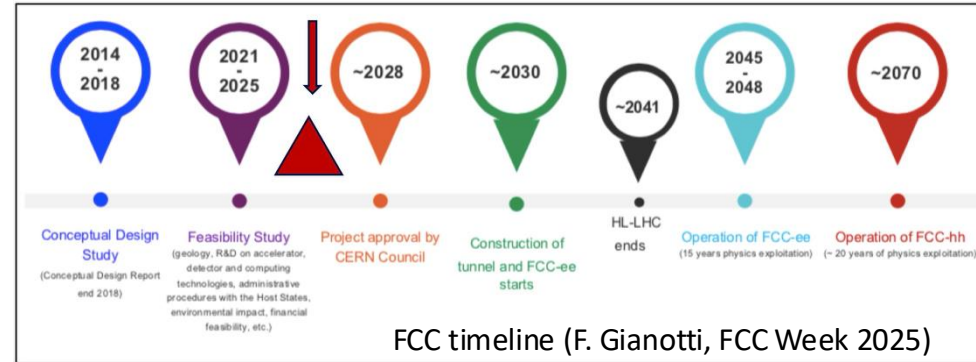

- At this stage there is no formation of any collaboration planned yet, no commitment by any of the groups, we would just like to start listing interested institutes and groups who are planning to possibly contribute in one way or another to the ALLEGRO detector concept. We are very open to any contributions and proposals for sub-detectors provided they are thought to be suited to comply with the physics benchmarks of FCC-ee
- All generic aspects of the sub-detectors will be discussed in the dedicated central FCC PED Generic System Level Studies Meetings (see before), only detector-concept specific discussions will take place in the dedicated ALLEGRO meetings. Regular overviews of corresponding ALLEGRO developments will be given in the general Detector Concepts meetings.
- In the coming years there could be several options for the different ALLEGRO sub-detector systems. We encourage of course to work together and possibly converge. A down-selection to baseline options and the formation of a proto-collaboration we expect once a decision on FCC-ee has been taken and once we enter the CDR and later TDR phase (possibly in the coming 5 years → in line with the timeline proposed in the slide before: ~2028)
- Until then it is important that all sub-detectors get further developed within the DRDs, including system demonstrators and those detectors get fully integrated into the FCC SW to enable us to do ALLEGRO full detector simulations with different sub-detectors

Status of DRD Collaborations

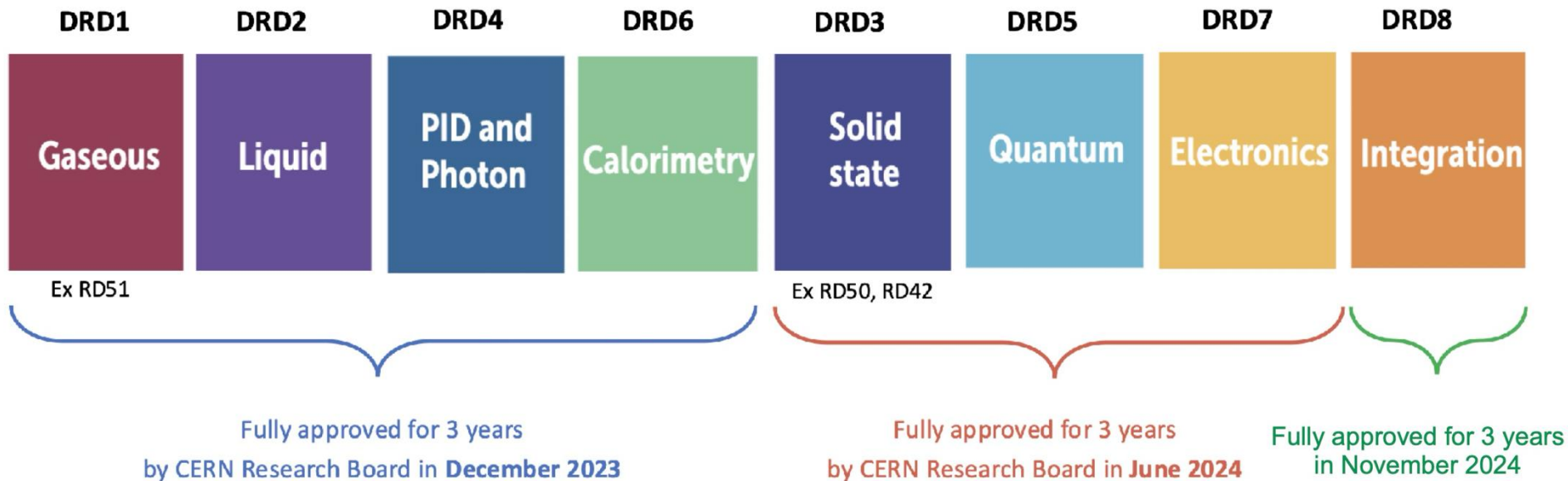

DRD Meetings: <https://indico.cern.ch/category/6805/>

M. Dam, FCC Week 2025

Conclusions

- **ALLEGRO** has been proposed as a **high-performance general-purpose detector concept for FCC-ee** – an **EoI was submitted for the ESU**
- There is a **strong noble-liquid ECAL** team (20 institutes) and a **strong HCAL** team (8 institutes)
- We have **collected interests to work on ALLEGRO** – no commitments at this stage, but interests expressed by 47 institutes, 170 authors
- In the coming years we should **further develop our ideas of detectors within the existing DRDs**, keeping the **physics requirements** in mind, **build prototype detectors** and **implement them into FCC SW** with **realistic performance**
- **No collaboration building at the moment, we will all work together in the framework of the FCC-PED Detector Concepts Work Package** (see meetings there on [tracker/calorimetry/muons/...](#))!
- The **invitation to join ALLEGRO** remains of course **open** – there is plenty of space to contribute!
- We expect a **decision on FCC-ee in 2-3 years** from now. Will then enter the CDR and later TDR phase.
- **Many interesting challenges ahead of us! Come and join us!**



Thank You for Your Attention! Time for Discussion!

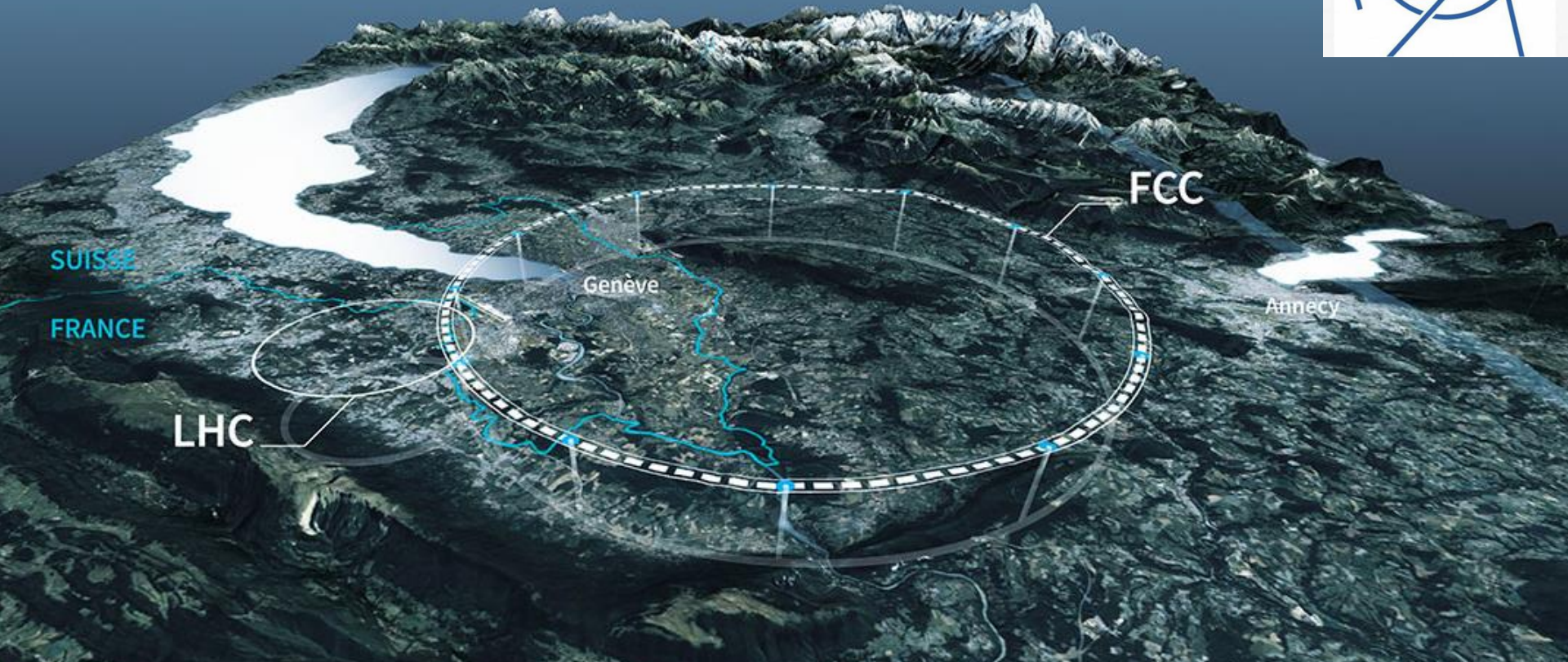

ALLEGRO Detector Concept – M. Aleksa



Back-Up

FCC-ee Summary of Machine Parameters

Parameter	Z	WW	H (ZH)	ttbar
beam energy [GeV]	45	80	120	182.5
beam current [mA]	1280	135	26.7	5.0
number bunches/beam	10000	880	248	36
bunch intensity [10^{11}]	2.43	2.91	2.04	2.64
SR energy loss / turn [GeV]	0.0391	0.37	1.869	10.0
total RF voltage 400/800 MHz [GV]	0.120/0	1.0/0	2.08/0	4.0/7.25
long. damping time [turns]	1170	216	64.5	18.5
horizontal beta* [m]	0.1	0.2	0.3	1
vertical beta* [mm]	0.8	1	1	1.6
horizontal geometric emittance [nm]	0.71	2.17	0.64	1.49
vertical geom. emittance [pm]	1.42	4.34	1.29	2.98
horizontal rms IP spot size [μm]	8	21	14	39
vertical rms IP spot size [nm]	34	66	36	69
luminosity per IP [$10^{34} \text{ cm}^{-2}\text{s}^{-1}$]	182	19.4	7.3	1.33
total integrated luminosity / year [ab^{-1}/yr] 4 IPs	87	9.3	3.5	0.65
beam lifetime (rad Bhabha + BS+lattice)	8	18	6	10

Currently assessing technical feasibility of changing operation sequence (e.g. starting at ZH energy)

4 years
 5×10^{12} Z
 $\text{LEP} \times 10^5$

2 years
 $> 10^8$ WW
 $\text{LEP} \times 10^4$

3 years
 2×10^6 H

5 years
 2×10^6 tt pairs

- x 10-50 improvements on all EW observables
- up to x 10 improvement on Higgs coupling (model-indep.) measurements over HL-LHC
- x10 Belle II statistics for b, c, τ
- indirect discovery potential up to ~ 70 TeV
- direct discovery potential for feebly-interacting particles over 5-100 GeV mass range

Up to 4 interaction points \rightarrow robustness, statistics, possibility of specialised detectors to maximise physics output

The Challenge – High Precision Measurements

Observable	present value \pm error	FCC-ee Stat.	FCC-ee Syst.	Comment and leading exp. error
m_Z (keV)	91186700 \pm 2200	4	100	From Z line shape scan Beam energy calibration
Γ_Z (keV)	2495200 \pm 2300	4	25	From Z line shape scan Beam energy calibration
$\sin^2 \theta_W^{\text{eff}} (\times 10^6)$	231480 \pm 160	2	2.4	from $A_{FB}^{\mu\mu}$ at Z peak Beam energy calibration
$1/\alpha_{\text{QED}}(m_Z^2) (\times 10^3)$	128952 \pm 14	3	small	from $A_{FB}^{\mu\mu}$ off peak QED&EW errors dominate
$R_t^Z (\times 10^3)$	20767 \pm 25	0.06	0.2-1	ratio of hadrons to leptons acceptance for leptons
$\alpha_s(m_Z^2) (\times 10^4)$	1196 \pm 30	0.1	0.4-1.6	from R_t^Z above
$\sigma_{\text{had}}^0 (\times 10^3)$ (nb)	41541 \pm 37	0.1	4	peak hadronic cross section luminosity measurement
$N_\nu (\times 10^3)$	2996 \pm 7	0.005	1	Z peak cross sections Luminosity measurement
$R_b (\times 10^6)$	216290 \pm 660	0.3	< 60	ratio of $b\bar{b}$ to hadrons stat. extrapol. from SLD
$A_{FB,0}^b (\times 10^4)$	992 \pm 16	0.02	1-3	b-quark asymmetry at Z pole from jet charge
$A_{FB}^{\text{pol},\tau} (\times 10^4)$	1498 \pm 49	0.15	< 2	τ polarization asymmetry τ decay physics
τ lifetime (fs)	290.3 \pm 0.5	0.001	0.04	radial alignment
τ mass (MeV)	1776.86 \pm 0.12	0.004	0.04	momentum scale
τ leptonic ($\mu\nu_\mu\nu_\tau$) B.R. (%)	17.38 \pm 0.04	0.0001	0.003	e/μ /hadron separation
m_W (MeV)	80350 \pm 15	0.25	0.3	From WW threshold scan Beam energy calibration
Γ_W (MeV)	2085 \pm 42	1.2	0.3	From WW threshold scan Beam energy calibration
$\alpha_s(m_W^2) (\times 10^4)$	1170 \pm 420	3	small	from R_t^W
$N_\nu (\times 10^3)$	2920 \pm 50	0.8	small	ratio of invis. to leptonic in radiative Z returns
m_{top} (MeV/ c^2)	172740 \pm 500	17	small	From $t\bar{t}$ threshold scan QCD errors dominate
Γ_{top} (MeV/ c^2)	1410 \pm 190	45	small	From $t\bar{t}$ threshold scan QCD errors dominate
$\lambda_{\text{top}}/\lambda_{\text{top}}^{\text{SM}}$	1.2 \pm 0.3	0.10	small	From $t\bar{t}$ threshold scan QCD errors dominate
ttZ couplings	\pm 30%	0.5 – 1.5 %	small	From $\sqrt{s} = 365$ GeV run

- **FCC-ee EWPO measurements with unprecedented statistical precision**
 - e.g. 6×10^{12} hadronic Z decays at Z-pole
 - **Statistical precision** for EWPOs measured at the Z-pole is **typically 500 times smaller than the current uncertainties**
- **→ Systematic uncertainty dominant!**
- **→ Can achieve indirect sensitivity to new physics up to a scale $\Lambda_{\text{new physics}}$ of 70 TeV**
- **We therefore require:**
 - Better control of parametric uncertainties, e.g. PDFs, α_s, m_t, m_H
 - Higher order theoretical computations, e.g. N...NLO
 - Access to phase-space limited regions + understand correlations among bins in distributions
 - **Minimizing detector systematics**

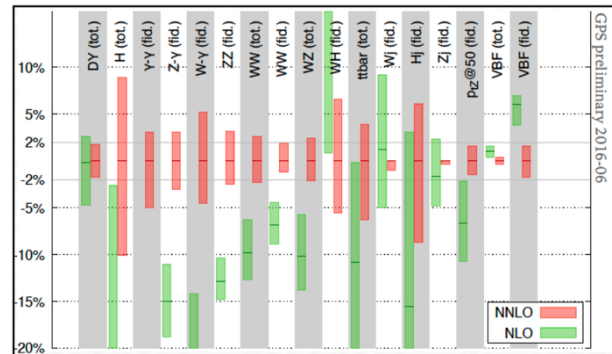

FCC-ee Physics Programme

"Higgs Factory" Programme

- At two energies, 240 and 365 GeV, collect in total
 - 1.2M HZ events and 75k WW → H events
- Higgs couplings to fermions and bosons
- Higgs self-coupling (2-4 σ) via loop diagrams
- Unique possibility: measure electron coupling in s-channel production $e^+e^- \rightarrow H$ @ $\sqrt{s} = 125$ GeV

Ultra Precise EW Programme & QCD

- Measurement of EW parameters with factor ~ 300 improvement in *statistical* precision wrt current WA
- 6×10^{12} Z and 3×10^8 WW
 - $m_Z, \Gamma_Z, \Gamma_{inv}, \sin^2\theta_W^{eff}, R_Z^e, R_b, \alpha_s, m_W, \Gamma_W, \dots$
 - 2×10^6 tt
 - $m_{top}, \Gamma_{top}, EW$ couplings
- Indirect sensitivity to new phys. up to $\Lambda=70$ TeV scale

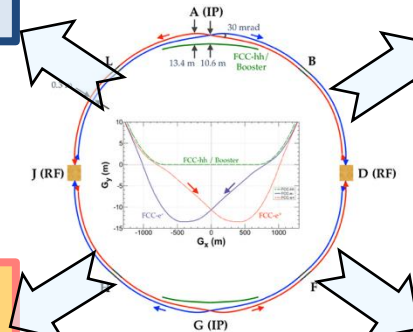

Heavy Flavour Programme

- Enormous statistics: 10^{12} bb, cc; 1.7×10^{11} $\tau\tau$
- Extremely clean environment, favourable kinematic conditions (boost) from Z decays
- CKM matrix, CP measurements, "flavour anomaly" studies, e.g. $b \rightarrow s\tau\tau$, rare decays, CLFV searches, lepton universality, PNMS matrix unitarity

Febly Coupled Particles - LLPs

- Intensity frontier: Opportunity to directly observe new feebly interacting particles with masses below m_Z :
- Axion-like particles, dark photons, Heavy Neutral Leptons
 - Signatures: long lifetimes – LLPs

Courtesy M. Dam

M. Aleksa (CERN)

FCC-ee Detector Requirements

"Higgs Factory" Programme

- Momentum resol. at $p_T \sim 50$ GeV of $\sigma_{p_T}/p_T \approx 10^{-3}$ commensurate with $\mathcal{O}(10^{-3})$ beam energy spread
- Jet energy resolution of 30%/√E in multi-jet environment for Z/W separation
- Superior impact parameter resolution for c, b tagging

Ultra Precise EW Programme & QCD

- Absolute normalisation (luminosity) to 10^{-4}
- Relative normalisation (e.g. Γ_{had}/Γ_ℓ) to 10^{-5}
- Momentum resolution "as good as we can get it"
 - Multiple scattering limited
- Track angular resolution < 0.1 mrad (BES from $\mu\mu$)
- Stability of B-field to 10^{-6} : stability of v_s meast.

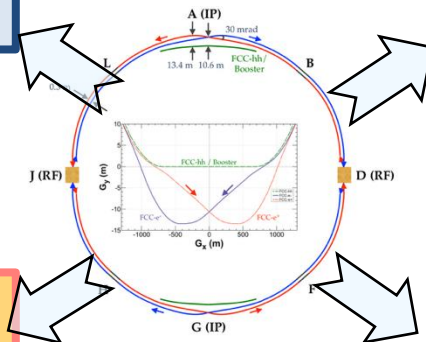

Heavy Flavour Programme

- Superior impact parameter resolution: secondary vertices, tagging, identification, life-time measts.
- ECAL resolution at the few %/√E level for inv. mass of final states with π^0 s or γ s
- Excellent π^0/γ separation and measurement for tau physics
- PID: K/ π separation over wide momentum range for b and τ physics

Feebly Coupled Particles - LLPs

- Benchmark signature: $Z \rightarrow \nu N$, with N decaying late
- Sensitivity to far detached vertices (mm \rightarrow m)
 - Tracking: more layers, continuous tracking
 - Calorimetry: granularity, tracking capability
 - Large decay lengths \Rightarrow extended detector volume
 - Precise timing for velocity (mass) estimate
 - Hermeticity

Courtesy M. Dam

M. Aleksa (CERN)

FCC-ee Physics Programme

Higgs & Top factory

m_H, σ, Γ_H
self-coupling
 $H \rightarrow bb, cc, ss, gg$
 $H \rightarrow inv$
 $ee \rightarrow H$
 $H \rightarrow bs, ..$

Top

$m_{top}, \Gamma_{top}, ttZ, FCNCs$

Excellent tracking
Jet energy resolution
at high energies

Flavor

"boosted" B/D/ τ factory:

CKM matrix
CPV measurements
Charged LFV
Lepton Universality
 τ properties (lifetime, BRs..)

$B_c \rightarrow \tau \nu$
 $B_s \rightarrow D, K/\pi$
 $B_s \rightarrow K^* \tau \tau$
 $B \rightarrow K^* \nu \nu$
 $B_s \rightarrow \varphi \nu \nu ...$

Excellent tracking /
energy resolution /
PID
at low energies

QCD - EWK

most precise SM test

$m_Z, \Gamma_Z, \Gamma_{inv}$
 $\sin^2 \theta_W, R^Z, R_b, R_c$

$A_{FB}^{b,c}, \tau$ pol.

$\alpha_S,$

m_W, Γ_W

Small systematics

BSM

feebly interacting particles

Heavy Neutral Leptons
(HNL)

Dark Photons Z_D

Axion Like Particles (ALPs)

Exotic Higgs decays

Versatile detector

FCC-ee Detector: Experimental Challenges

- **30 mrad beam crossing angle**
 - Detector B-field limited to 2 Tesla at Z-peak operation
 - Tightly packed MDI (Machine Detector Interface)
- **“Continuous” beams** (no bunch trains); bunch spacing down to ≤ 20 ns
 - Power management and cooling (no power pulsing as possible for linear coll.)
- **Extremely high luminosities**
 - High statistical precision – control of systematics down to 10^{-6} level
- **Physics events at up to 100 kHz**
 - Fast detector response
 - High occupancy in the inner layers and forward region (Bhabha scattering, $\gamma\gamma$ hadrons)
 - Beamstrahlung
 - Is trigger needed? Triggerless design challenging but rewarding
- **More physics challenges**
 - Absolute luminosity measurement to 10^{-4} – luminometer accept. to $\mathcal{O}(1 \mu\text{m})$ level
 - Detector acceptance to $\sim 10^{-5}$ – acceptance definition to few micro-radians, hermeticity (no cracks!)
 - Precise ν_s determination through quasi-continuous resonant depolarisation (RDP) measurements \rightarrow e.g. 50 keV at the Z pole
 - Stability of momentum measurement – stability of magnetic field wrt E_{cm} (10^{-6})

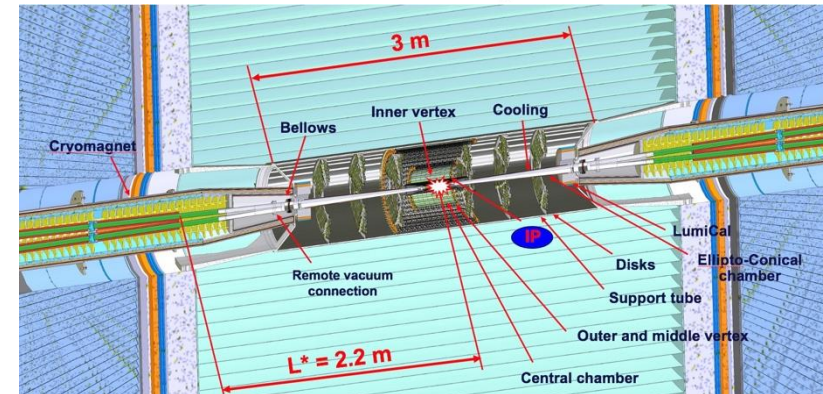
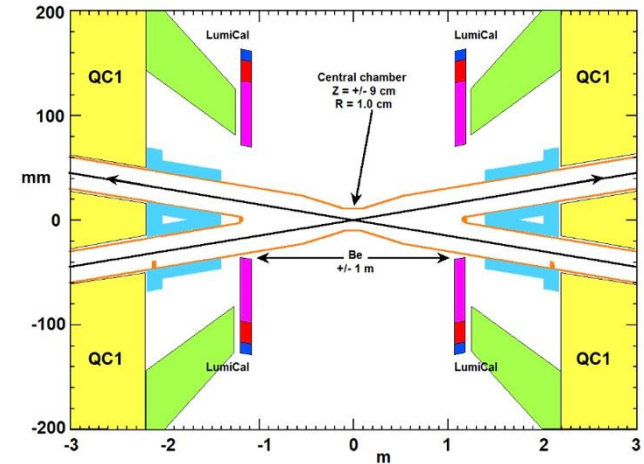

MDI region engineering has started

FCC-ee versus other e^+e^- Collider Options

Numbers of events in 15 years, tuned to maximise the physics outcome

					\sqrt{s} uncertainty	
ZH maximum	$\sqrt{s} \sim 240$ GeV	3 years	2×10^6	$e^+e^- \rightarrow \bar{Z}H$	Never done	2 MeV
$t\bar{t}$ threshold	$\sqrt{s} \sim 365$ GeV	5 years	2×10^6	$e^+e^- \rightarrow t\bar{t}$	Never done	5 MeV
Z peak	$\sqrt{s} \sim 91$ GeV	4 years	6×10^{12}	$e^+e^- \rightarrow Z$	LEP $\times 10^5$	< 50 keV
WW threshold+	$\sqrt{s} \geq 161$ GeV	2 years	3×10^8	$e^+e^- \rightarrow W^+W^-$	LEP $\times 10^3$	< 200 keV
[s-channel H	$\sqrt{s} = 125$ GeV	5* years	~ 8000	$e^+e^- \rightarrow H_{125}$	Never done	< 100 keV

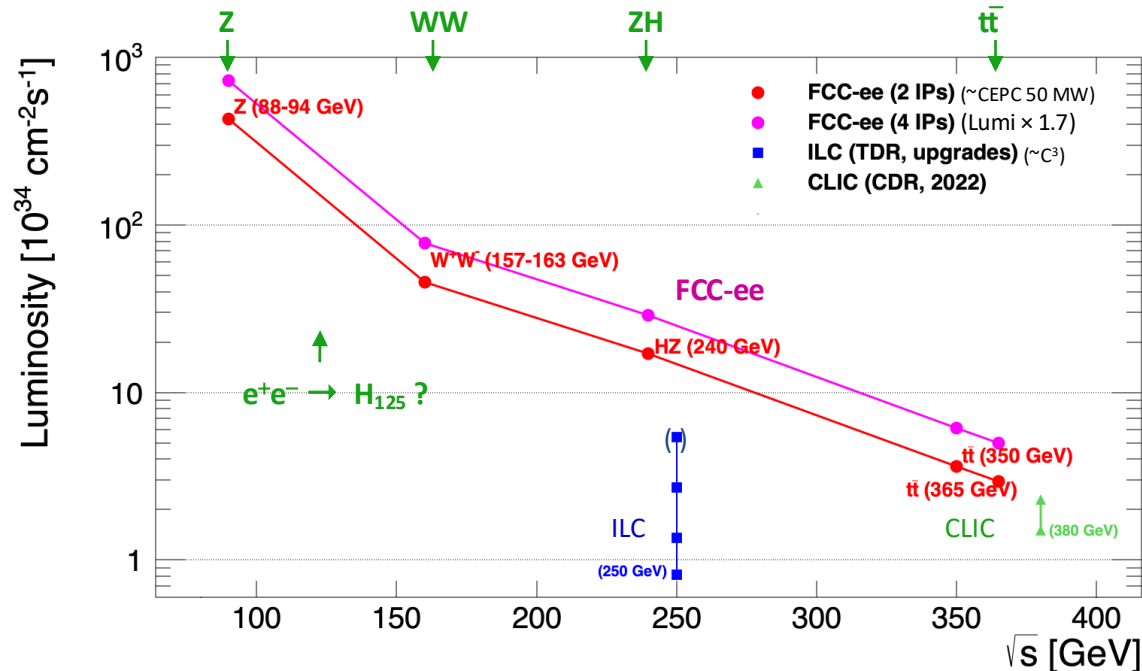

FCC-ee: ultimate precision with

- **$\sim 100\,000$ Z / second (!)**
 - 1 Z / second at LEP
 - **$\sim 10\,000$ W / hour**
 - 20 000 W in 5 years at LEP
 - **$\sim 1\,500$ Higgs bosons / day**
 - 10-20 times more than ILC
 - **$\sim 1\,500$ top quarks / day**
- ... in each detector

→ FCC-ee EWPO measurements with unprecedented statistical precision

e.g. 6×10^{12} hadronic Z decays at Z-pole

Statistical precision for EWPOs measured at the Z-pole is typically **500 times smaller than the current uncertainties**

→ **Systematic uncertainty dominant!**

Higgs Factory: Higgs Production and Decay

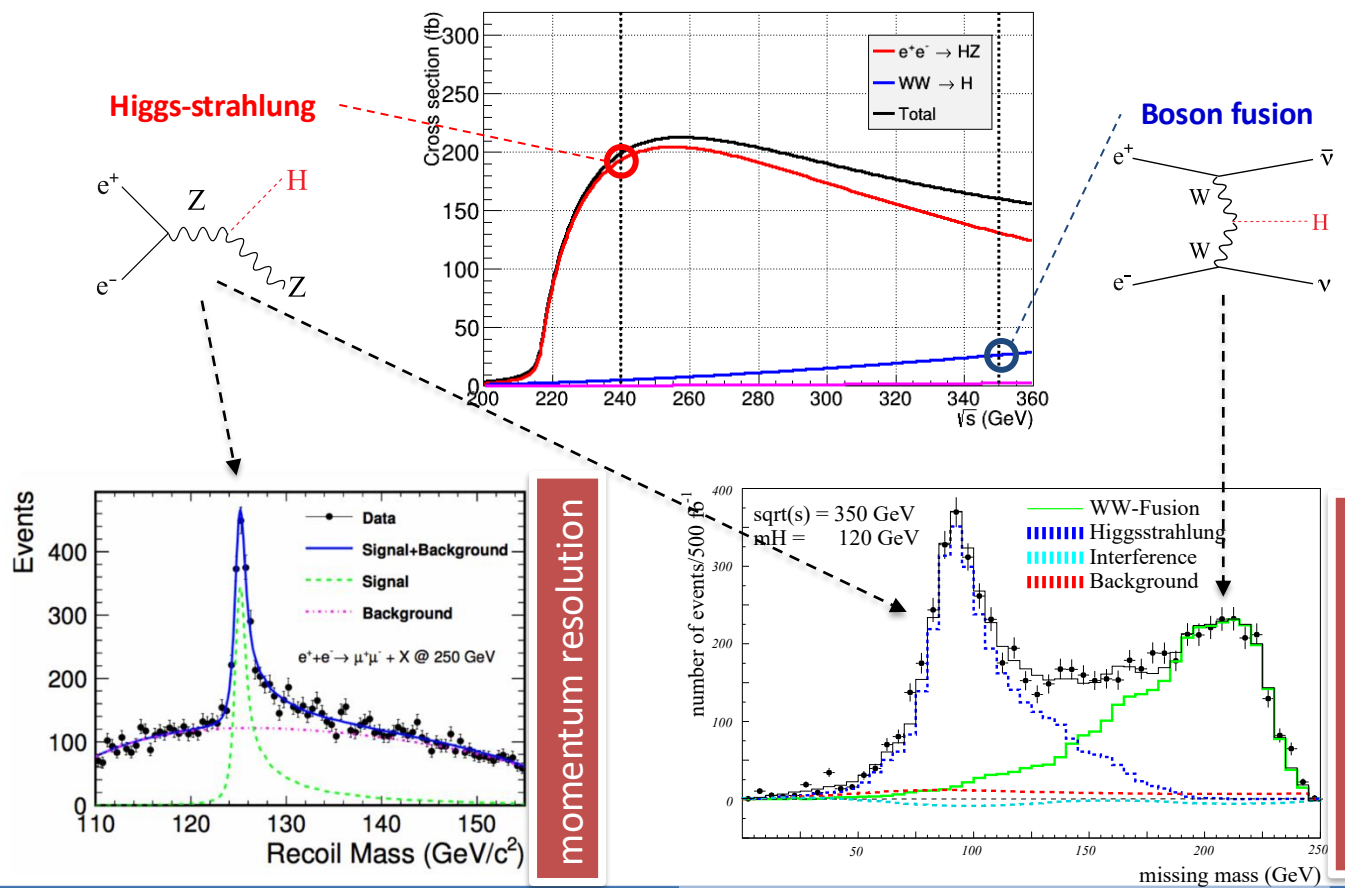

$M_H = 125$ GeV	SM BF
bb	56.1%
WW*	23.1%
gg	8.2%
$\tau\tau$	6.3%
ZZ*	2.6%
cc	2.9%
$\gamma\gamma$	0.2%
Z γ	0.15%
ss	0.1%
$\mu\mu$	0.02%

flavour tagging

Vertex Detector and Tracking

Flavour Tagging:
Impact parameter
"design goal" ...

$$\sigma_{d_0} = a \oplus \frac{b}{p \sin^{3/2} \theta}$$

$a \simeq 5 \mu\text{m}; \quad b \simeq 15 \mu\text{m GeV}$

arXiv:1911.12230

e.g. CLD flavour tagging

b-tagging

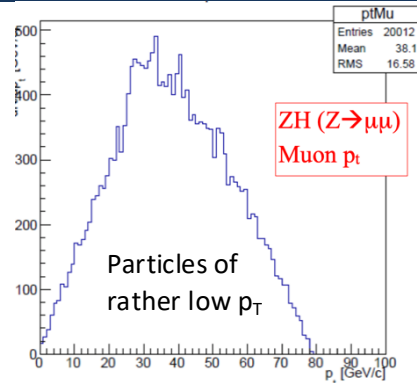
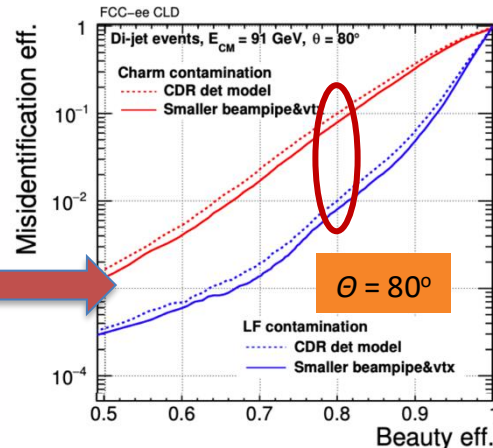
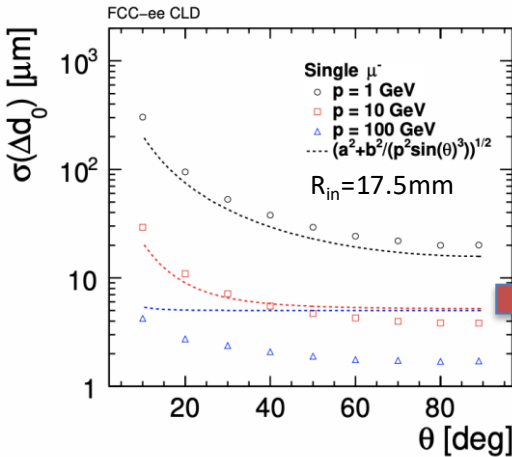

→ Momentum resolution
multiple scattering dominated

$$\sigma(p_T)/p_T^2 = a \oplus \frac{b}{p \sin \theta}$$

$$\frac{\Delta p_T}{p_T} \Big|_{m.s.} \approx \frac{0.0136 \text{ GeV}/c}{0.3\beta B_0 L_0} \sqrt{\frac{d_{tot}}{X_0 \sin \theta}}$$

Ambitious goal: $\sigma_{p_T}/p_T \simeq 10^{-3} @ 50\text{GeV}$

→ Flavour tagging – Vertex Detector: Lighter, more precise (smaller pixel size), closer to IP

→ Momentum Resolution – Tracking Detector: The lighter the better

	r beam pipe	1 st VTX layer
ILC	12 mm	14 mm
CLIC	29 mm	31 mm
FCC-ee	10 mm	12 mm

Particle Identification

- **PID capabilities across a wide momentum range** essential for flavour studies and enhance overall physics reach
- **Drift chamber** promises $>3\sigma$ π/K separation all the way up to 100 GeV
 - dE/dx cross-over window at 1 GeV, can be alleviated by unchallenging TOF measurement of $\delta T \lesssim 0.5$ ns
- **Time of flight (TOF) alone** δT of ~ 10 ps over 2 m
 - could give 3σ π/K separation up to ~ 5 GeV
- **Alternative approaches**, in particular (gaseous) **RICH** counters are also investigated (e.g. A pressurized RICH Detector – ARC)

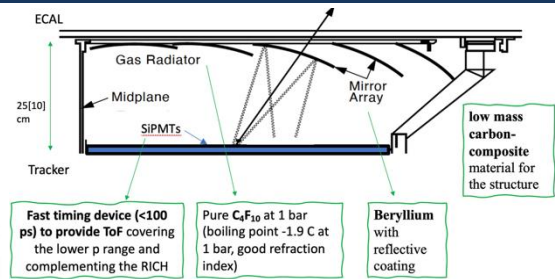

FCC Workshop, Feb. 2022
Proposal for EP R&D WP3 (DRD4)

Possible RICH layout in an FCC-ee experiment

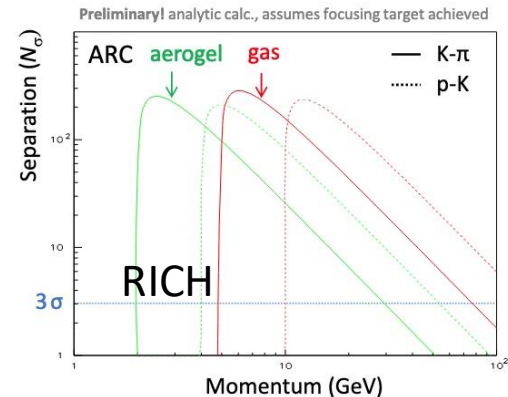
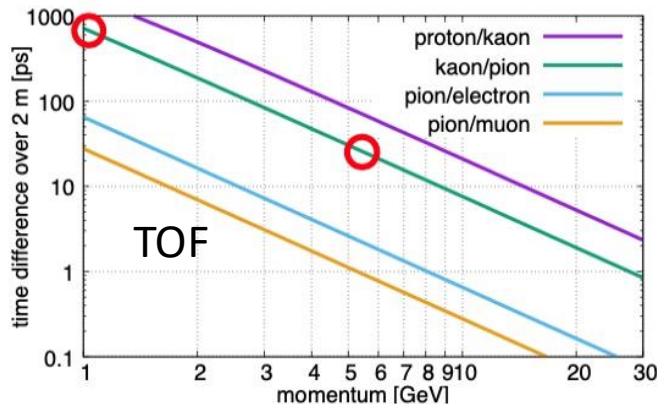
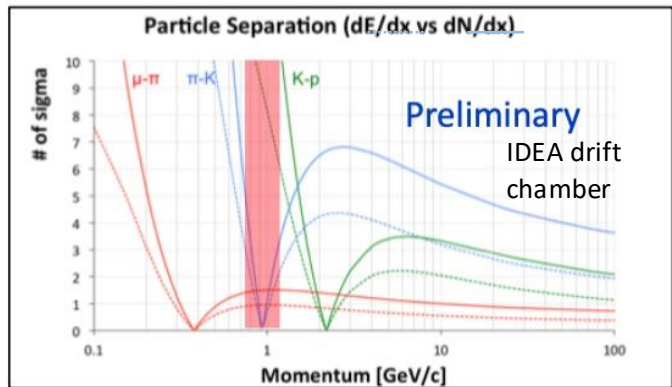
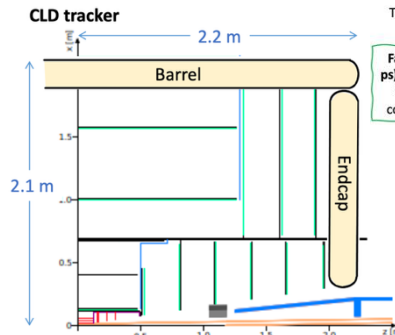

DRDCalo WP2 – ALLEGRO ECAL

WP2 reminder: organisational structure

See [talk by Zuchen Huang](#) on Thursday

• **Currently** contributing institutes

- APC (Paris, France)
- BNL (Brookhaven, USA)
- Brown University (Providence, USA)
- CERN
- CPPM (Marseille, France)
- CUNI (Prague, Czech Republic)
- IFIN-HH + UNSTPB (Bucharest, Romania)
- IJCLab (Orsay, France)
- LAPP (Annecy, France)
- LPSC (Grenoble, France)
- MPI Munich (Germany)
- NYU (NY, USA)
- Omega (Palaiseau, France)
- Southern Methodist University (Dallas, USA)
- Stony Brook University (USA)
- TU Dresden (Germany)
- IEP SAS Kosice (Slovakia)
- University of Arizona (USA)
- University of Columbia (NY, USA)
- UT Austin (USA)

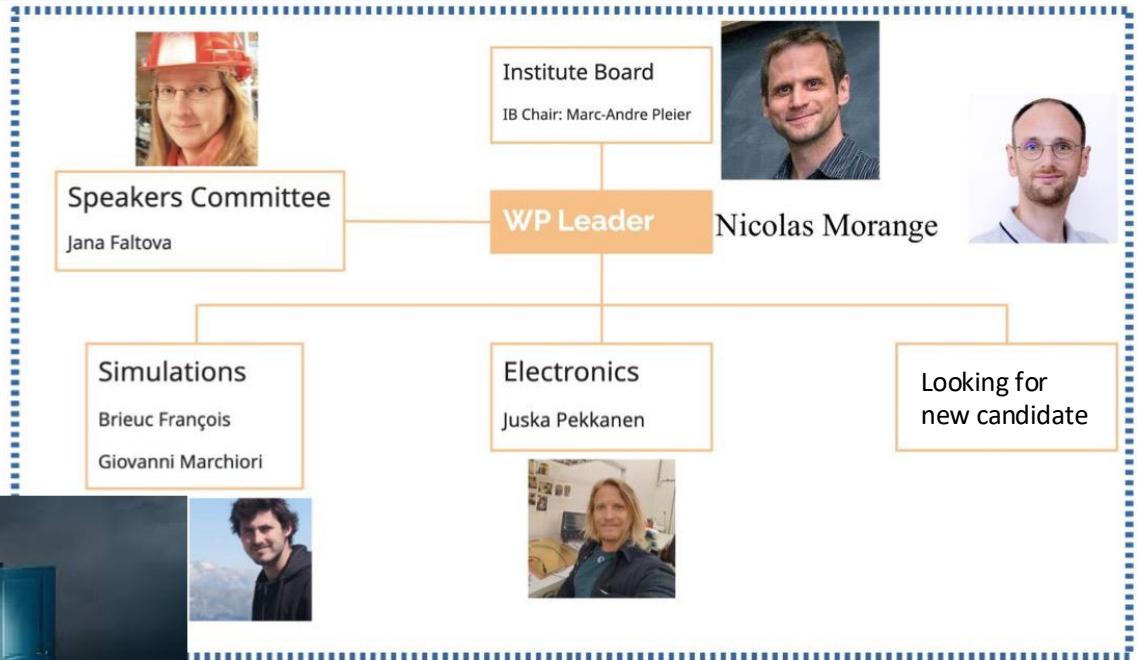

**20 institutes in
8 countries**

Web Page: <https://allegro.web.cern.ch>

ALLEGRO ECAL (now DRDCalo WP2) Meetings:

<https://indico.cern.ch/category/18309/> & <https://indico.cern.ch/category/8922/>

Calorimetry

Energy coverage < 300 GeV → 22 X₀, 7λ

Precise jet angular resolution

Jet energy: $\sigma(E_{\text{jet}})/E_{\text{jet}} \approx 30\% / \sqrt{E} [\text{GeV}]$?

⇒ **Mass reconstruction from jet pairs**

Resolution important for control of (combinatorial) backgrounds in multi-jet final states with E_T^{miss}

How to achieve jet energy res. of ~3-4% at 50GeV:

- **Highly granular calorimeters**
- **Particle flow reconstruction and possibly in addition techniques to correct non-compensation (e/h≠1), e.g. dual read-out**

- **Excellent Jet resolution:** $\approx 30\%/\sqrt{E}$
- **ECAL resolution:**
 - Higgs physics $\approx 15\%/\sqrt{E}$
 - But for heavy flavour programme better resolution beneficial: → 8%/√E → 3%/√E
- **Fine segmentation for PF algorithm and powerful γ/π^0 separation and measurement**

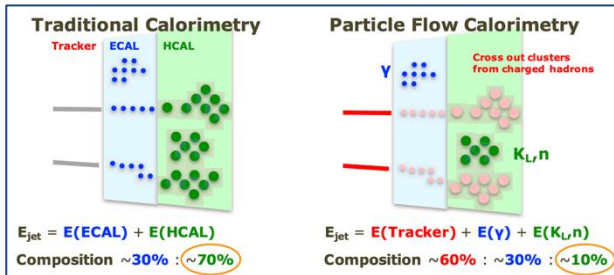

Detector technology (ECAL & HCAL)	E.m. energy res. stochastic term	E.m. energy res. constant term	ECAL & HCAL had. energy resolution (stoch. term for single had.)	ECAL & HCAL had. energy resolution (for 50 GeV jets)	Ultimate hadronic energy res. incl. PFflow (for 50 GeV jets)
Highly granular Si/W based ECAL & Scintillator based HCAL	15 – 17% [12,20]	1% [12,20]	45 – 50% [45,20]	≈ 6% ?	4% [20]
Highly granular Noble liquid based ECAL & Scintillator based HCAL	8 – 10% [24,27,46]	< 1% [24,27,47]	≈ 40% [27,28]	≈ 6% ?	3 – 4% ?
Dual-readout Fibre calorimeter	11% [48]	< 1% [48]	≈ 30% [48]	4 – 5% [49]	3 – 4% ?
Hybrid crystal and Dual-readout calorimeter	3% [30]	< 1% [30]	≈ 26% [30]	5 – 6% [30,50]	3 – 4% [50]

For more information see <https://link.springer.com/article/10.1140/epjp/s13360-021-02034-2>

Calorimetry

Energy coverage < 300 GeV \rightarrow 22 X_0 , 7 λ

Precise jet angular resolution

Jet energy: $\sigma(E_{\text{jet}})/E_{\text{jet}} \approx 30\% / \sqrt{E} [\text{GeV}]$?

\Rightarrow Mass reconstruction from jet pairs

Resolution important for control of (combinatorial) backgrounds in multi-jet final states with E_T^{miss}

How to achieve jet energy res. of $\sim 3\text{-}4\%$ at 50GeV:

- Highly granular calorimeters
- Particle flow reconstruction and possibly in addition techniques to correct non-compensation ($e/h \neq 1$), e.g. dual read-out

- Excellent Jet resolution: $\approx 30\%/\sqrt{E}$
- ECAL resolution:
 - Higgs physics $\approx 15\%/\sqrt{E}$
 - But for heavy flavour programme better resolution beneficial: $\rightarrow 8\%/\sqrt{E} \rightarrow 3\%/\sqrt{E}$
- Fine segmentation for PF algorithm and powerful γ/π^0 separation and measurement

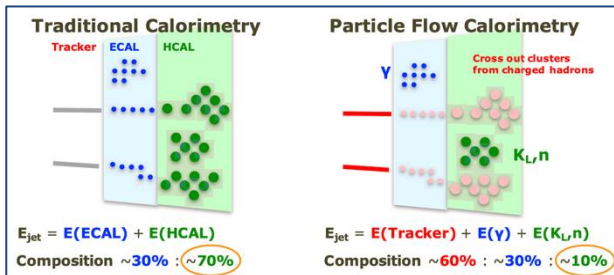

Detector technology (ECAL & HCAL)	E.m. energy res. stochastic term	E.m. energy res. constant term	ECAL & HCAL had. energy resolution (stoch. term for single had.)	ECAL & HCAL had. energy resolution (for 50 GeV jets)	Ultimate hadronic energy res. incl. PFlow (for 50 GeV jets)
Highly granular Si/W based ECAL & Scintillator based HCAL	15 – 17% [12,20]	1% [12,20]	45 – 50% [45,20]	$\approx 6\%$?	4% [20]
Highly granular Noble liquid based ECAL & Scintillator based HCAL	8 – 10% [24,27,46]	< 1% [24,27,47]	$\approx 40\%$ [27,28]	$\approx 6\%$?	3 – 4% ?
Dual-readout Fibre calorimeter	11% [48]	< 1% [48]	$\approx 30\%$ [48]	4 – 5% [49]	3 – 4% ?
Hybrid crystal and Dual-readout calorimeter	3% [30]	< 1% [30]	$\approx 26\%$ [30]	5 – 6% [30,50]	3 – 4% [50]

For more information see <https://link.springer.com/article/10.1140/epjp/s13360-021-02034-2>

Example – Stability of ATLAS LAr Energy Scale

- **Noble-liquid calorimetry:** High intrinsic stability (see gain and pedestal stability)
 - Pedestal stability < 100 keV (!)
 - Gain stability 2.6×10^{-4}
- These parameters are monitored in daily calibration runs \rightarrow constants are updated when necessary (about once a month)
- \rightarrow Leading to high stability of the energy scale of 2×10^{-4} , monitored by invariant mass m_{ee} ($Z \rightarrow ee$ events) and E/p

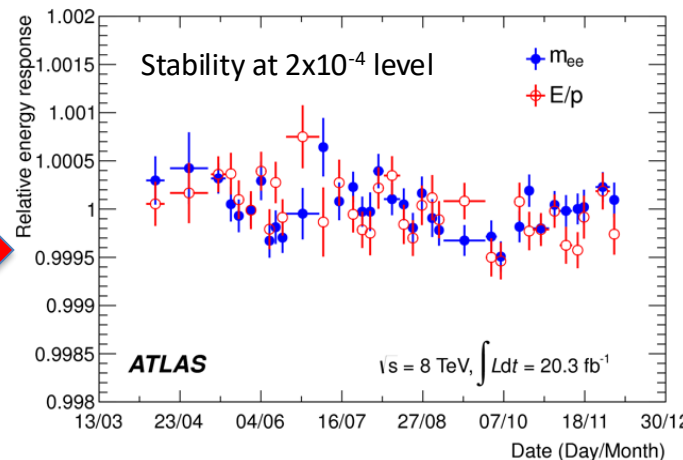
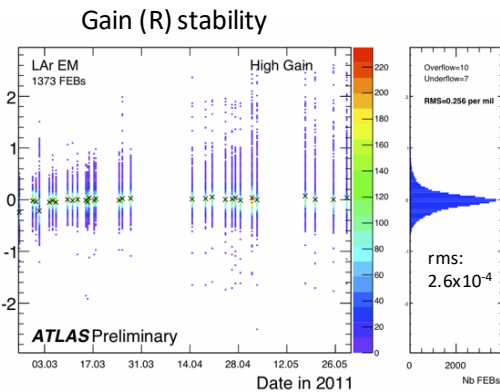
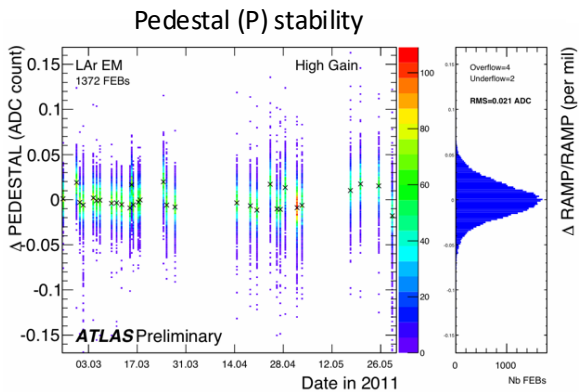

Granularity – What are the Limits in ATLAS LAr?

- In the ATLAS LAr calorimeter electrodes have 3 layers that are glued together ($\sim 275\mu\text{m}$ thick)
 - 2 HV layers on the outside
 - 1 signal layer in the middle
- \rightarrow All cells have to be connected with fine signal traces (2-3mm) to the edges of the electrodes
 - Front layer read at inner radius
 - Middle and back layer read at outer radius
- \rightarrow limits lateral and longitudinal granularity
- \rightarrow maximum 3 long. layers

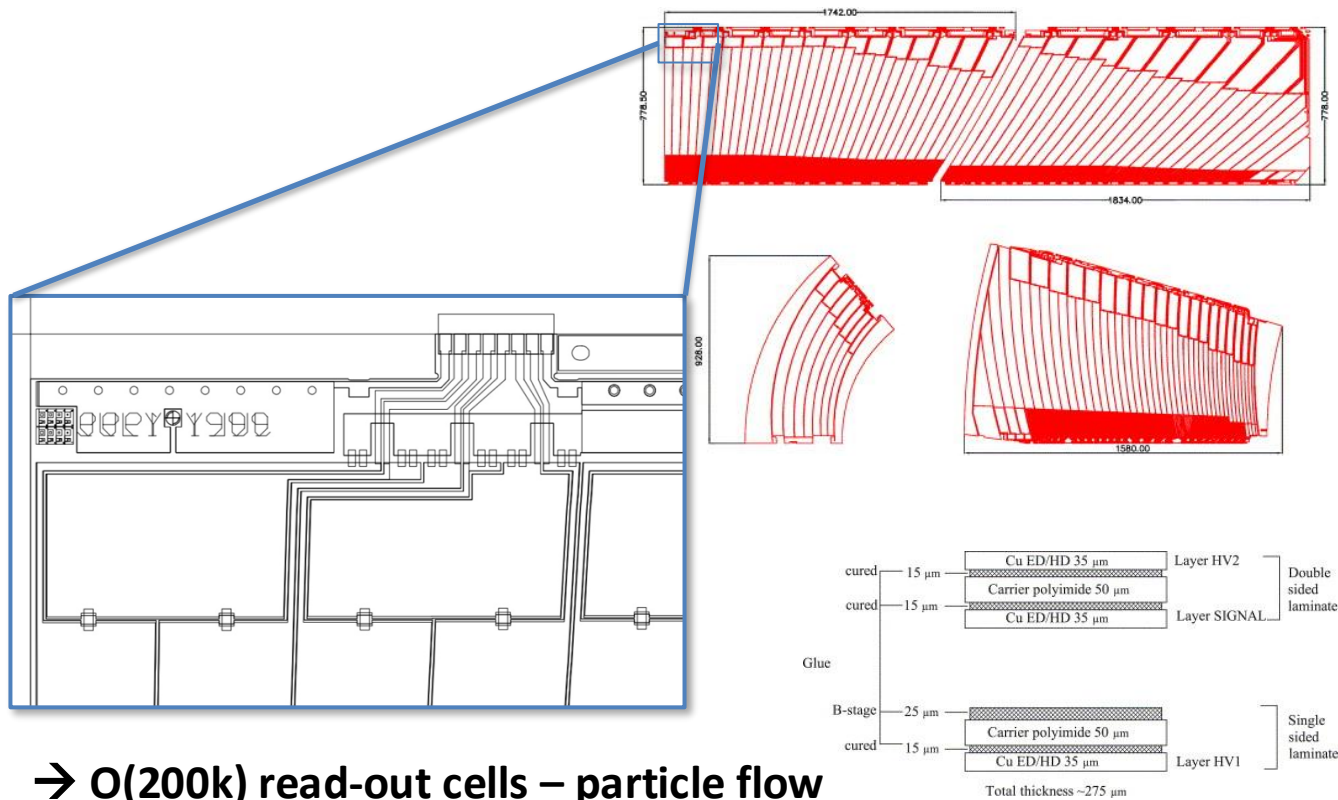
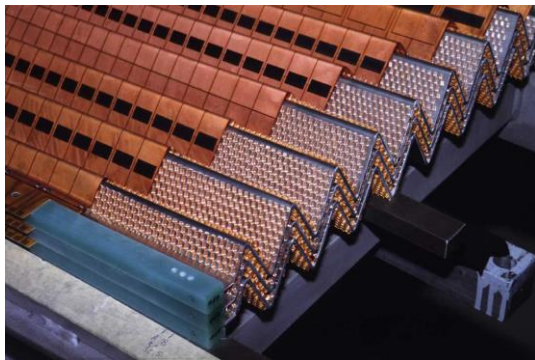

\rightarrow $O(200\text{k})$ read-out cells – particle flow reconstruction possible, but not optimal

Noble-Liquid Calo: How to Achieve High Granularity?

Realize electrodes as multi-layer PCBs

($H=1.2\text{mm}$ thick), 5 to 7 layers

- HV and read-out
- Signal traces (width w_t) in dedicated signal layer connected with vias to the signal pads
- Traces shielded by ground-shields (width w_s , dist. h_s) forming $50\Omega - 80\Omega$ transmission lines
 - Optimizing between 0, 1 or 2 shield layers
- \rightarrow capacitance between shields and signal pads C_s will add to the detector capacitance via the gap C_d
- $\rightarrow C_{cell} = C_s + C_d \approx 25 - 300\text{pF}$
- The higher the granularity the more shields are necessary $\rightarrow C_s$ increases, C_d decreases (smaller cells)

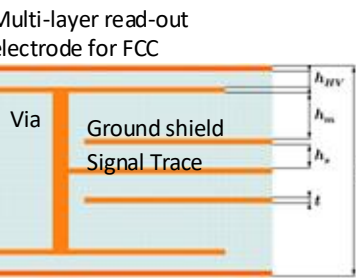
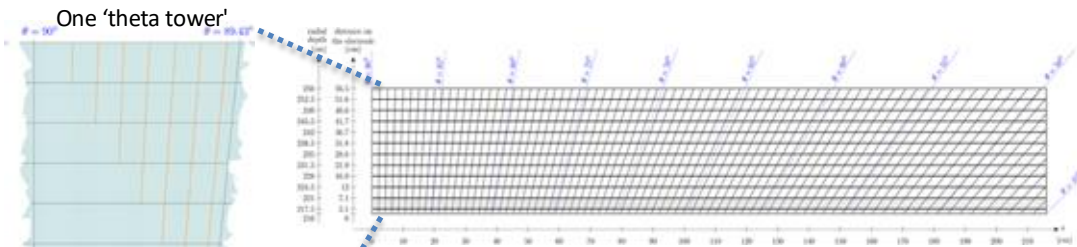

Total capacitance (no trace)

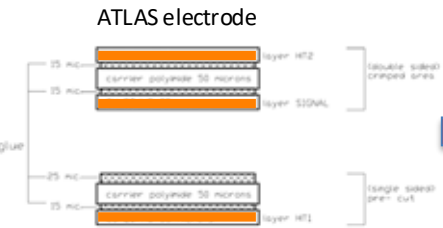
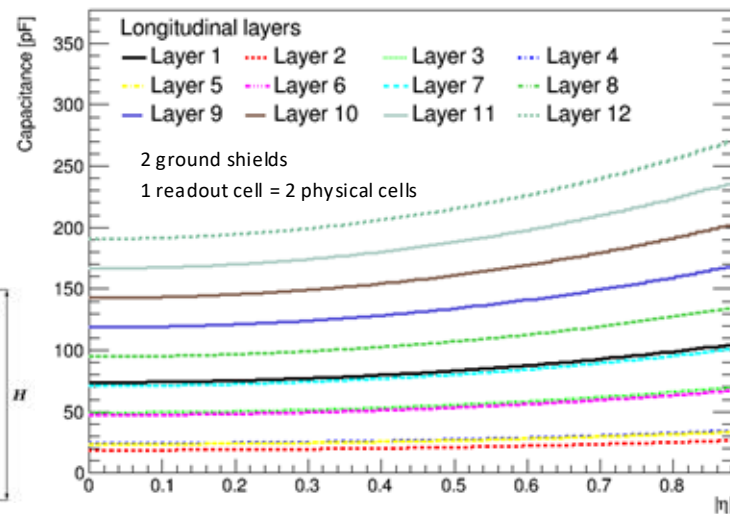

In principle any granularity realisable \rightarrow cost in cross-talk and noise \rightarrow careful optimization!

Work Ahead (Not ALLEGRO Specific)

General: Develop a detector that match the performance set by physics benchmarks

- **Vertex Detector & MDI Region:**
 - Sensor technology exists (MAPS, EP R&D WP1.2, DRD3), but light weight support structures, low-material power and cooling infrastructure needs to be developed
 - Continue & strengthen engineering effort on MDI region, support of vertex detectors and LumiCal – develop MDI for all detector concepts
- **Tracking:**
 - Different proposals: Scintillating Fibre tracker, Si tracker (DRD3), gaseous tracker (DRD1): drift chamber, straw tracker
 - Minimize material, start engineering of support structures, services, power, cooling...
- **Particle ID:**
 - Interesting ideas to complement e.g. Si tracker with ARC
 - Low GWP gases/gels for Cherenkov detectors
 - ToF detector (e.g. LGADs)
- **Calorimetry:**
 - Continue building prototypes of all proposed calorimeters, testbeams (DRD6)
 - Define needed granularity, performance optimization
 - Engineering
- **Muon Tagger / Muon System:**
 - Large area gas detectors, technology exists
 - Need to define what is needed for optimal physics reach
 - Low GWP gases for gas detectors (e.g. RPC)
- **Software:**
 - Detector concepts existing in FCCSW, modular approach, can easily plug in new detectors, new ideas
 - Particle flow starting to work, but needs tuning
- **Trigger and DAQ:**
 - Do we need a trigger or can we read out everything (additional power & cooling → more material)
 - Closely linked to studies of occupancies caused by background (Bhabha scattering, $\gamma\gamma$ hadrons, Beamstrahlung)
- **Magnets:**
 - Effort to re-establish availability of a reinforced aluminum-stabilized Nb-Ti conductors needed for FCC-ee, as well as to investigate novel HTS-based conductor technology and its implications (EP R&D WP8)
- **Cryostats:**
 - Further development of low-material carbon-composite cryostats as well as carbon fibre and aluminum honeycomb (EP R&D WP4)
 - Tightness of flanges to stainless steel feed-throughs
 - Tests of prototypes