



VNIVERSITAT
ID VALÈNCIA



CSIC
CONSEJO SUPERIOR DE INVESTIGACIONES CIENTÍFICAS

AITANA IFIC INSTITUT DE
FÍSICA
CORPUSCULAR

Progress on ML cavity BPM tests at ATF and new cavity BPM design

Laura Karina Pedraza, Nuria Fuster, Daniel Esperante, Juan Carlos Fernández,
César Blanch, Daniel González, Marça Boronat, Benito Gimeno

Cold cavity BPM R&D, 02/03/2026



laura.pedraza@ific.uv.es



Progress on ML cavity BPM tests at ATF and new cavity BPM design

Cold cavity BPM R&D, 02/03/2026

Introduction

- I. December results at ATF (Saclay BPM)
 - A) Hardware changes
 - B) Signal processing improvements
 - C) Best resolution results

- II. New cBPM prototype and measurements
 - A) Simulated RF parameters
 - B) Measurements of the new prototype
 - C) Simulation / measurements comparison

Conclusion

I. December results at ATF (Saclay BPM)

A) Hardware changes

- Changing of the LO resonance frequency to achieve lower IF
- Implementation of a phase shifter of the LO to maximise sensitivity
- Additional down-conversion stage to reduce the IF frequency even more

The **phase shifter** allows to tune ϕ_{LO} so that the amplitude of the IF signal is higher where the exponential envelope is higher.

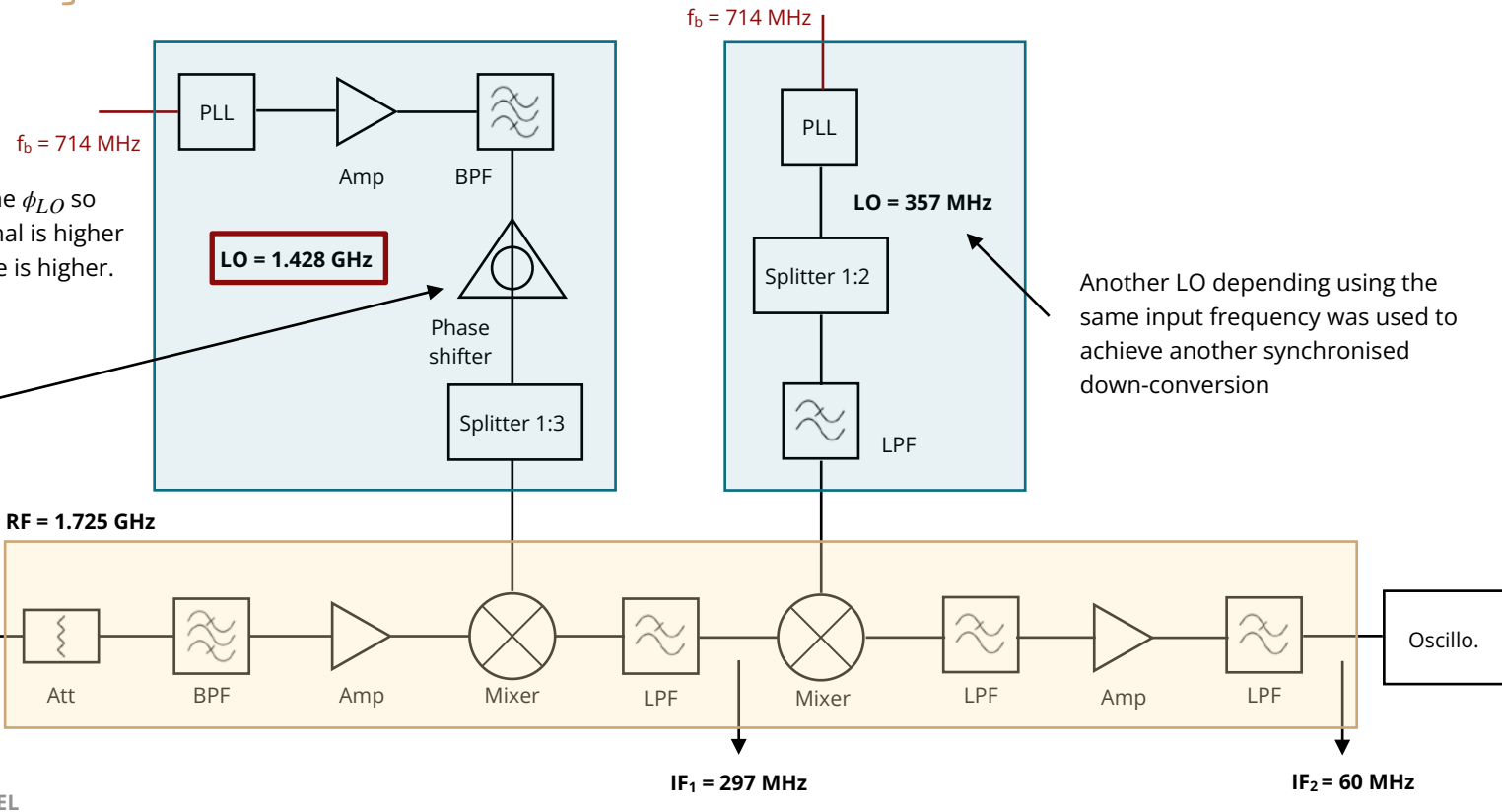
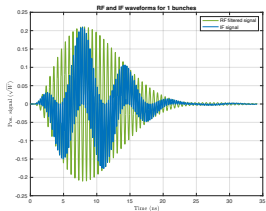

I. December results at ATF (Saclay BPM)

B) Signal processing improvements

Changes that were implemented on the DDC, calibration and resolution algorithms:

- Re-sampling:**

removes interpolated points added by the oscilloscope

- Calibration:**

fixing the statical offset → provides more accurate cBPM measurements

- Time-stamps comparison:**

selecting only measurements that correspond to the same bunch for all BPMs

- Fixed sampling point:**

unifies the way the waveform is processed and avoids different position result when there is a reflection of the waveform

- Removing frozen stripline BPMs**

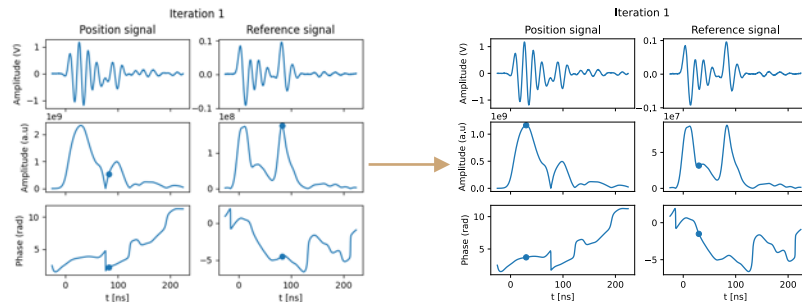
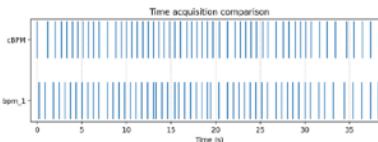
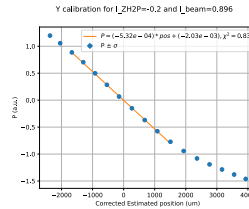
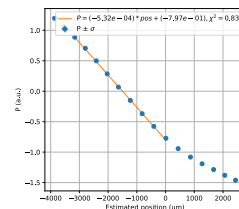
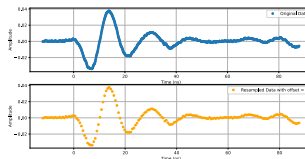

I. December results at ATF (Saclay BPM)

C) Best resolution results

From the calibration fit, we can obtain the dynamic range and χ^2 which indicates the quality of the linear fit (the closer to 1, the better)

The best resolution was typically found at 0.88 nC/bunch and when the beam is positioned closer to the center.

The best result was observed for the double down-conversion.

Best resolution for double down-conversion

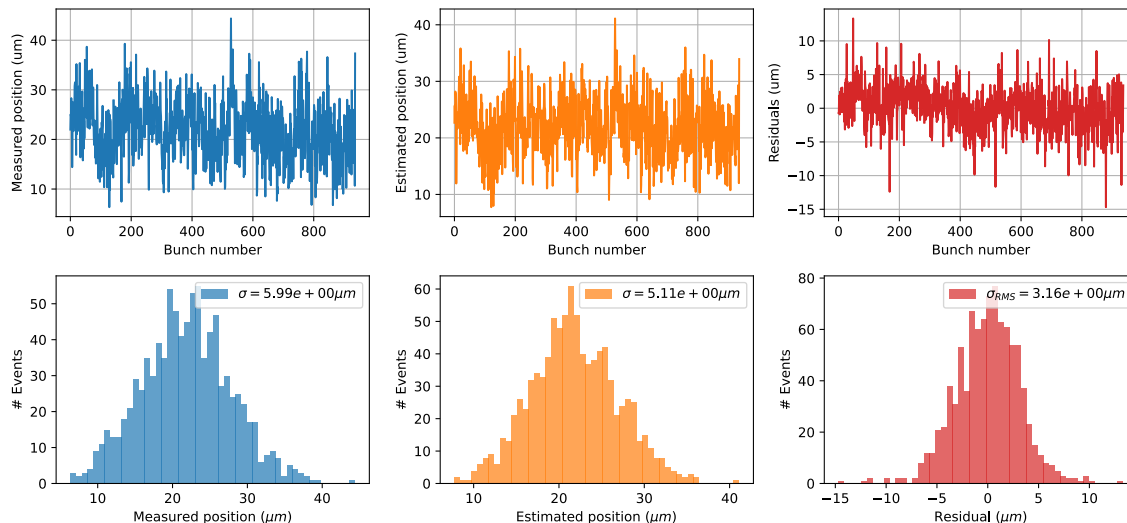

Setup	Calibration fit		Resolution measurements		
	Dynamic range	χ^2	Bunch charge	Beam position	Resolution
Lower IF frequency	1.5 mm	3.66	0.89 nC	0.20 mm	4.45 μm
LO - phase shifter	1.5 mm	4.26	0.88 nC	0.10 mm	4.63 μm
Double down-conversion	1.0 mm	2.46	0.88 nC	0.02 mm	3.16 μm

Progress on ML
cavity BPM tests
at ATF and new
cavity BPM design

Cold cavity BPM R&D, 02/03/2026

Introduction

- I. December results at ATF (Saclay BPM)
 - A) Hardware changes
 - B) Signal processing improvements
 - C) Best resolution results
- II. New cBPM prototype and measurements
 - A) Simulated RF parameters
 - B) Measurements of the new prototype
 - C) Simulation / measurements comparison

Conclusion

II. New cBPM prototype and measurements

A) Simulated RF parameters

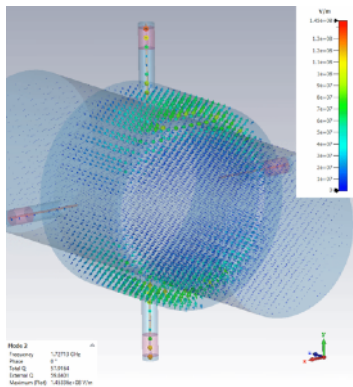

$$l_{up} = 4.5$$

$$l_{step} = 3$$

$$l_{down} = 8$$

$$a_{tab} = 3$$

$$r_{blend} = 1.5$$

$$e_{tab} = 0.3$$

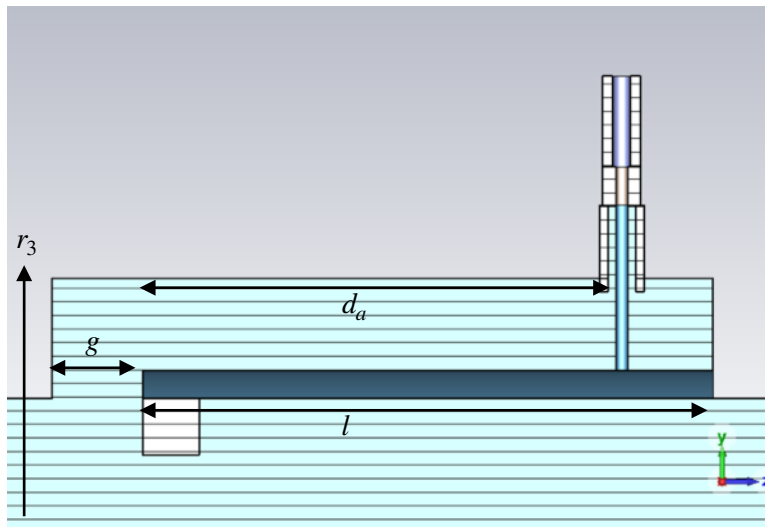
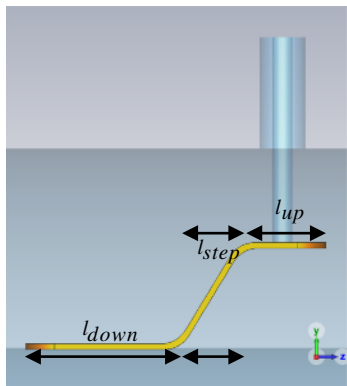

Parameters optimisation (mm):

$$r_3 = 51.75$$

$$l = 53.3$$

$$d_a = 47$$

$$g = 10.25$$

Mode	Monopole					Dipole (on x)				
	Freq (GHz)	Q _L	R/Q (Ω) @ 5 mm	S ₁₁ (dB)	S ₁₂ (dB)	Freq (GHz)	Q _L	R/Q (Ω) @ 5 mm	S ₁₁ (dB)	S ₁₂ (dB)
CEA SACLAY	1.250	22.95	12.9	-	-	1.719	50.96	0.27	-25.0	-33
Optimization (ideal)	1.120	37.65	14.47			1.626	72.30	0.357	-16.3	-30.6
After tab optimization	1.118	34.91	14.50	-5.48	-6.52	1.620	64.09	0.350	-20.2	-30.8

II. New cBPM prototype and measurements

B) Measurements of the new prototype

Metrology:

All BPM dimensions were according to specifications.
Tolerances were according to specifications.

Vector Network Analyzer (VNA):

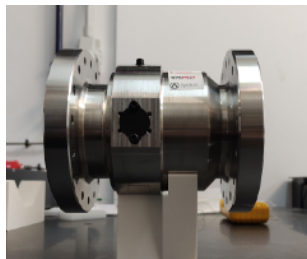

Resistivity:

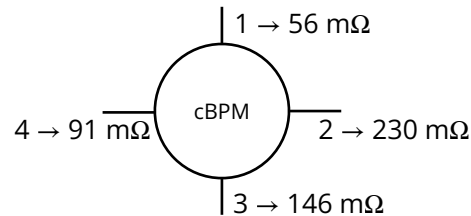

Initial problem with port 3 (was giving ~700 mΩ) but it was solved by loosening it slightly.

Vacuum test: Approved

Reflection:
At the same port

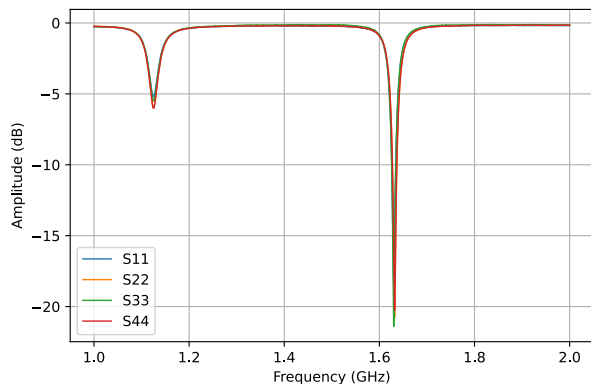

Cross-talk:
Between the 4 consecutive ports

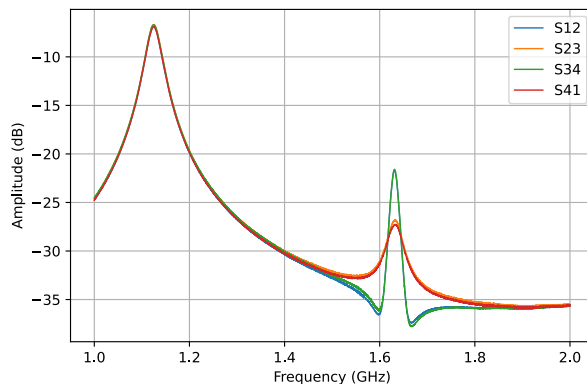

Transmission:
Between the opposite ports

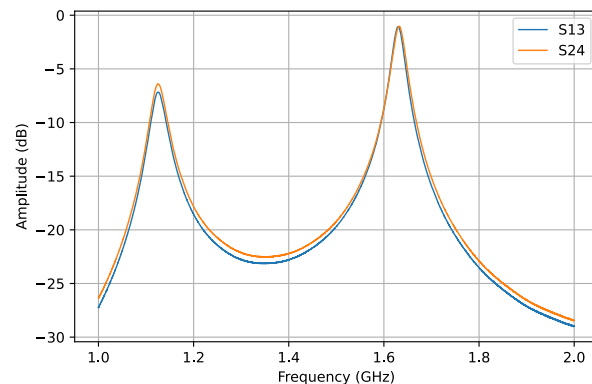

II. New cBPM prototype and measurements

C) Simulation / measurements comparison

Mode	Monopole					Dipole (on x)				
	Freq (GHz)	Q _L	R/Q (Ω) @ 5 mm	S ₁₁ (dB)	S ₁₂ (dB)	Freq (GHz)	Q _L	R/Q (Ω) @ 5 mm	S ₁₁ (dB)	S ₁₂ (dB)
Saclay BPM simulated	1.250	22.95	12.9	-	-	1.719	50.96	0.27	-25.0	-33
Saclay BPM measured	1.255	30.99	-	-5.91	-6.47	1.724	46.40	-	-22.85	-32.7
New BPM simulated	1.118	34.91	14.50	-5.48	-6.52	1.620	64.09	0.350	-20.2	-30.8
New BPM measured	1.125	46.98	-	-5.70	-6.89	1.631	57.84	-	-20.76	-24.30

The new BPM shows measured RF parameters close to the simulations and within the specifications required. The only under-performing parameter is the transmission between orthogonal ports that leads to cross-talk. Efforts on the electronics are being employed to compensate for this.

The new BPM will be tested in May-June 2026 in ATF, according to the plan. We anticipate at least 4 shifts to perform calibration and resolution tests.

Thank you for your attention

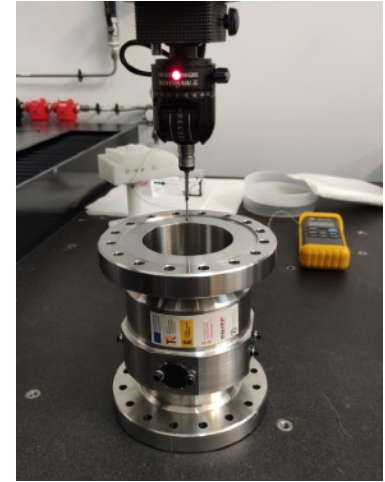
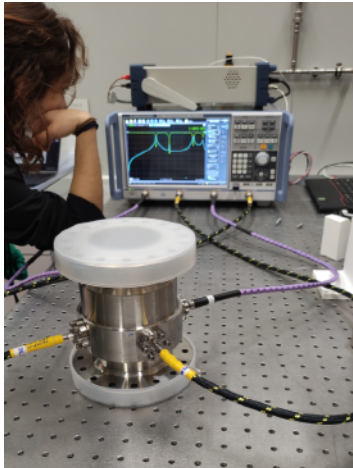

We gratefully acknowledge the ATF staff for their assistance during the installation and BPM measurements. Special thanks to Toshiyuki Okugi, Alex Aryshev, and Konstantin Popov for their support. We also thank Toshihiro Matsumoto and Hiroshi Kaji for providing the necessary equipment for the measurements.

This work has the support of "Plan de Recuperación, Transformación y Resiliencia (PRTR) 2022 (ASFAE/2022/013)", funded by Conselleria d'Innovació, Universitats, Ciència i Societat Digital from Generalitat Valenciana, and NextGenerationEU from European Union.

This work was partially supported by the European Union's Horizon Europe Marie Skłodowska-Curie Staff Exchanges programme under grant agreement no. 101086276.

laura.pedraza@ific.uv.es

Back-up slides

A. Cavity BPM working principle

1) The CEA Saclay BPM

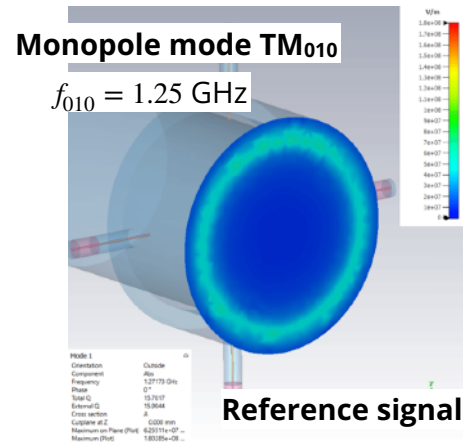

Proportional to the beam charge q

→ **Output signal on the time domain:**

The position signal oscillates at the dipole mode resonance frequency and decays exponentially with decay constant τ

$$V_{position}(t) = V_{out,0} \sin(\omega_{110}t + \varphi) \exp(-t/\tau)$$

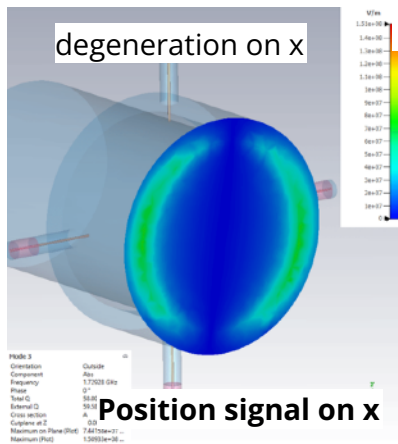

Dipole modes TM_{110}

$$f_{010} = 1.72$$
 GHz

Proportional to the beam charge q and the beam position δx or δy

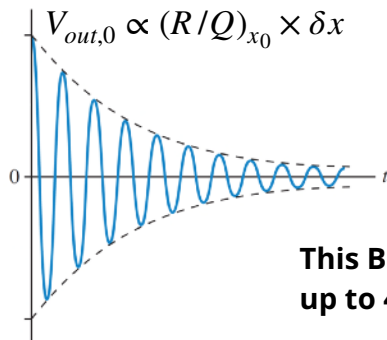
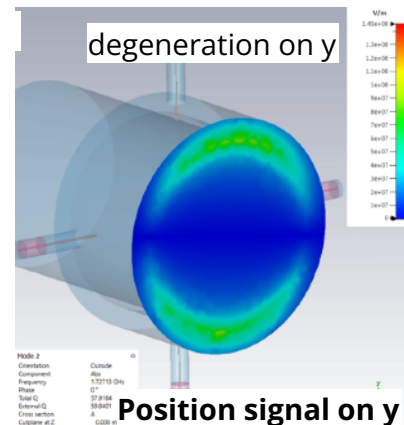

Need to measure the amplitude and the phase to determine the beam position

This BPM has proven to have a resolution up to 4 μm with a dynamic range of ± 5 mm