



- ✓ SCQ standalone test cryostat
- ✓ BPM interface

Tomohiro Yamada
KEK Accelerator laboratory

Test cryostat



Purpose, Motivation and Feature

- Cryogenic testing of SCQ magnet before installing into the cryomodule.
E.g. Current excitation, magnetic field measurement
- The cryostat has inner diameter that can install not only SCQ but also “SCQ+BPM”.
- Hinge type flanges enable us to open and close without using an overhead crane. This feature makes easy to adjust the SCQ and BPM if we could install it to STF accelerator beam line.



Specification of the cryostat

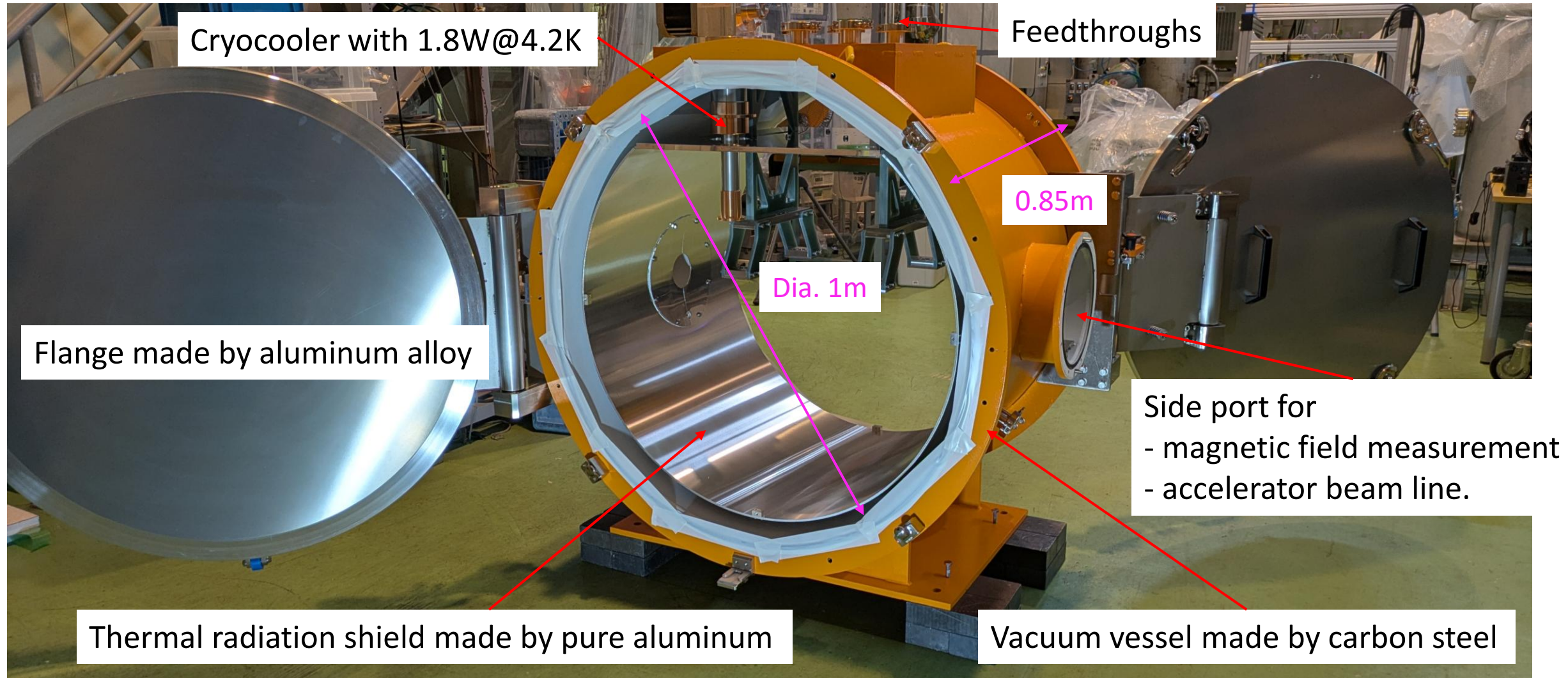

BPM assembly for ILC CM



- ✓ All cavities are assembled in ISO class4 clean room, however, the SCQ must be assembled outside clean room because of its “dirtiness”, meaning a lot of adhesive and impossibility of ultra sonic bath washing, etc...
- ✓ BPM should be assembled inside clean room in the process of cavity assembly. A vacuum pipe is located in the SCQ section. Two 180 deg parts of the SCQ will be assembled around the pipe outside the clean room.

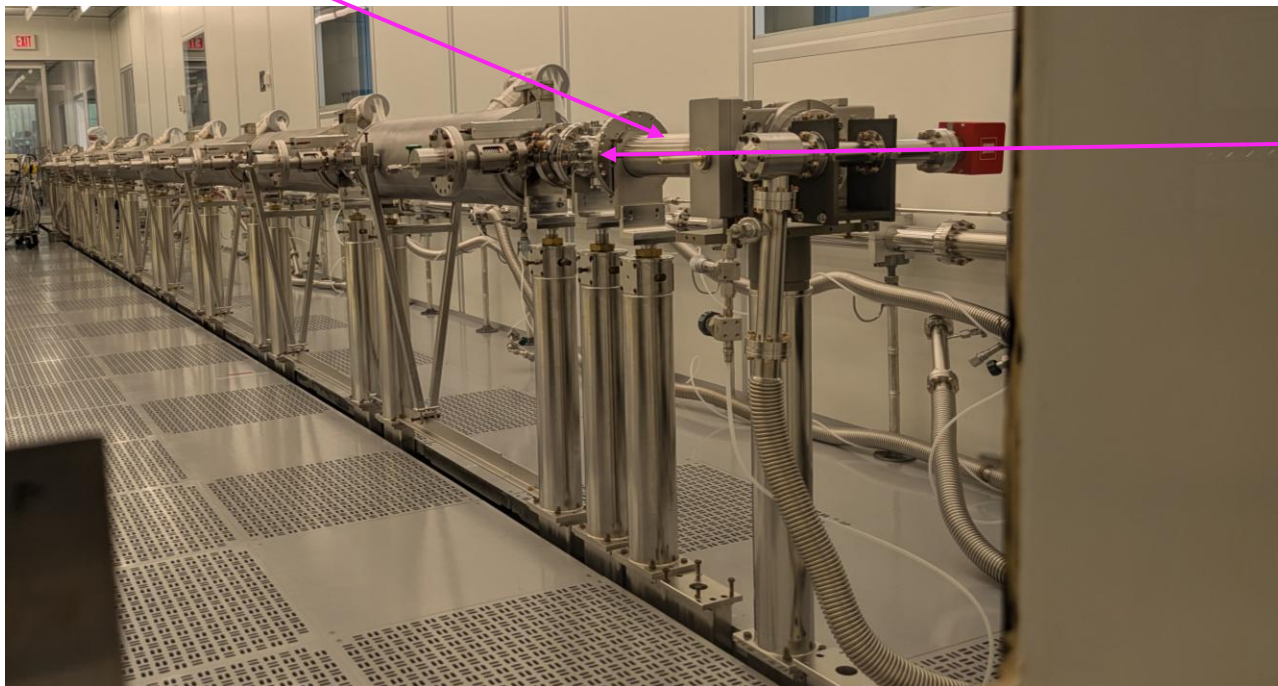

Cavity string assembly for **LCLS-II**

BPM is located at the end of cavity string.

In ILC, it is located at the center of the string.

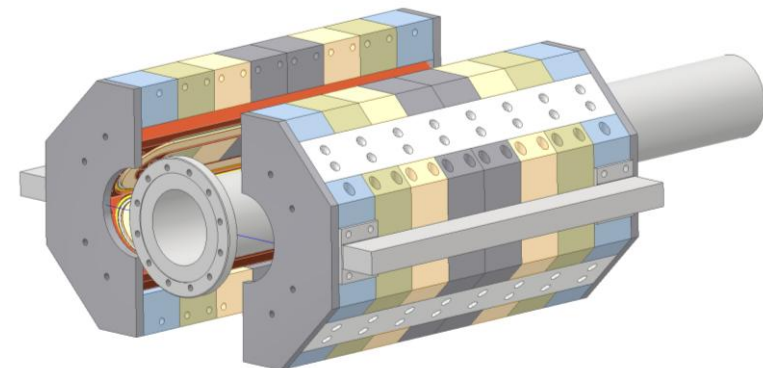

BPM interface plate



- : M6 screw hole
- : Dia 5mm hole +8, -0um

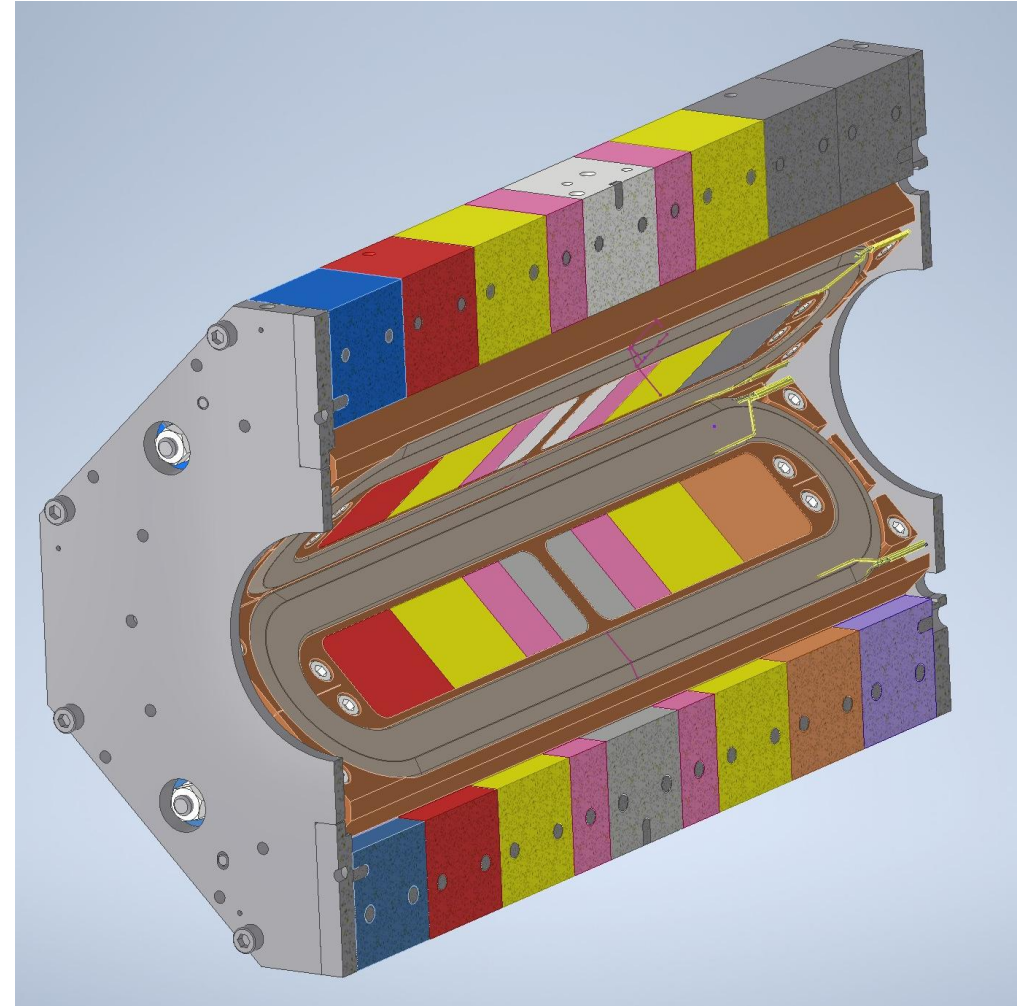
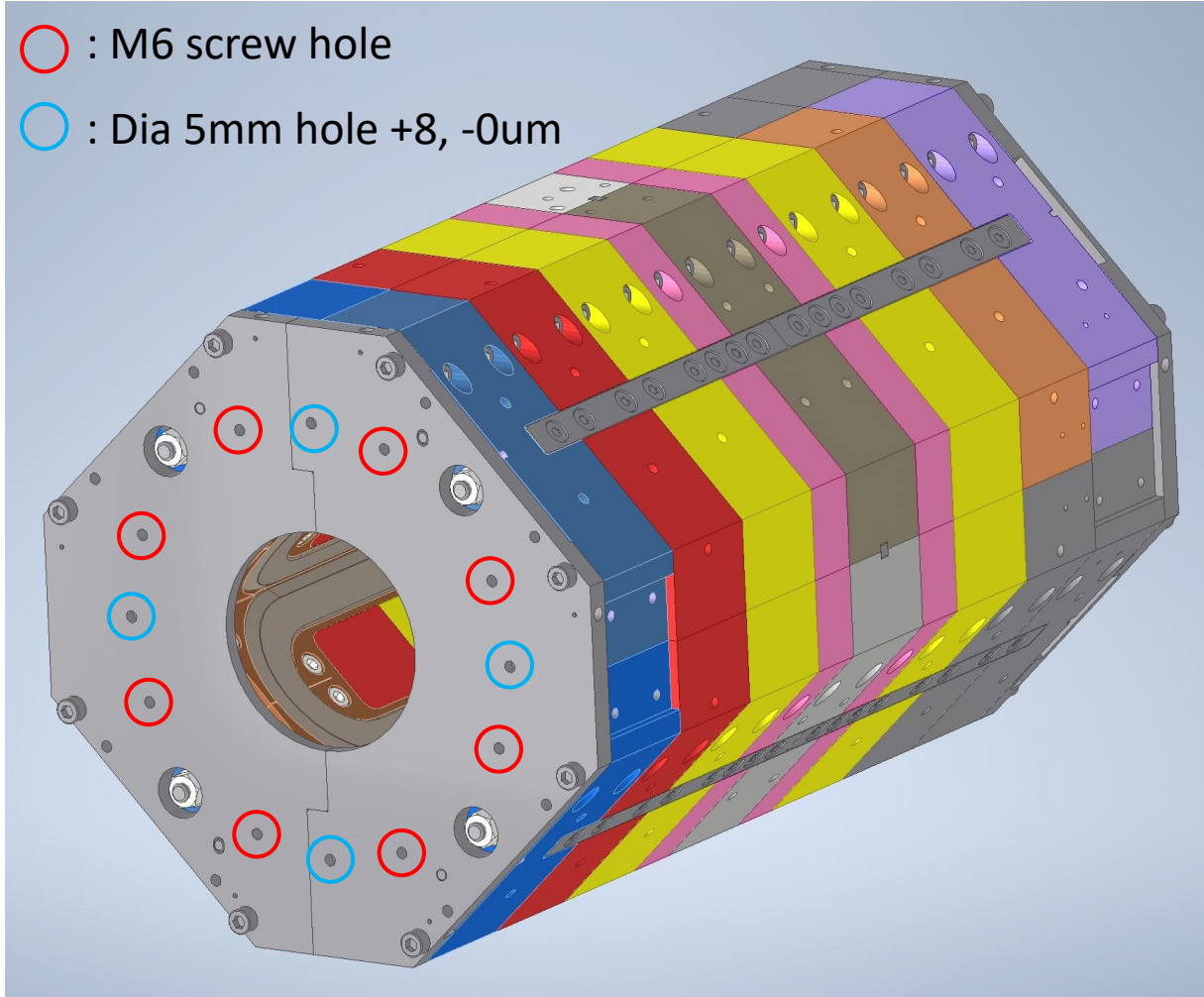

Previous version of cryostat...
But assembled layout can be understood

