

Upgrade plans for LHC detectors

Cristina Fernández Bedoya
on behalf of the LHC experiments



November 25th 2013
V CPAN Days
Santiago de Compostela

LHC Upgrades

European Strategy for Particle Physics (2013):

“Europe’s top priority should be the exploitation of the full potential of the LHC, including the high-luminosity upgrade of the machine and detectors”

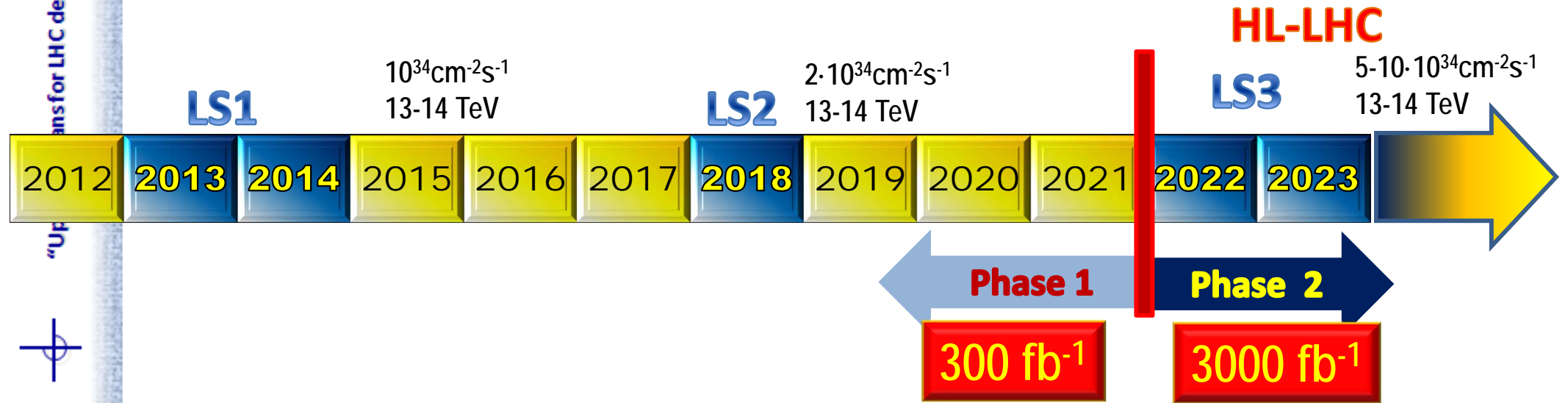

10 times more luminosity:

- Large sensitivity to wide range of Higgs boson property measurements
- Searches for new particles at higher energy
- Unique worldwide facility to look for rare processes
- Greater sensitivity to flavour physics and rare probes of the quark gluon plasma

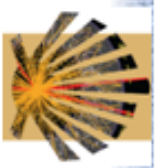

Challenges at High Luminosity



Same physics but at higher luminosity...

* Higher Occupancy:

- * hits on detector elements proportional to the number of interactions, problems of detectors granularity and buffers occupancy

* Radiation damage to detectors and electronics:

- * Peak luminosity: reduced mean time between failures for SEE (Single Event Effects)
- * Integrated luminosity: charge trapping in silicon, increased noise and dark current, light absorption in crystals, etc

* Event pile-up:

- * Trigger efficiency, event size, DAQ bandwidth, computing power...
- * Particle and event reconstruction, missing ET measurement, particle isolation definition, backgrounds to signal processes...



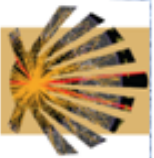

ALICE and LHCb

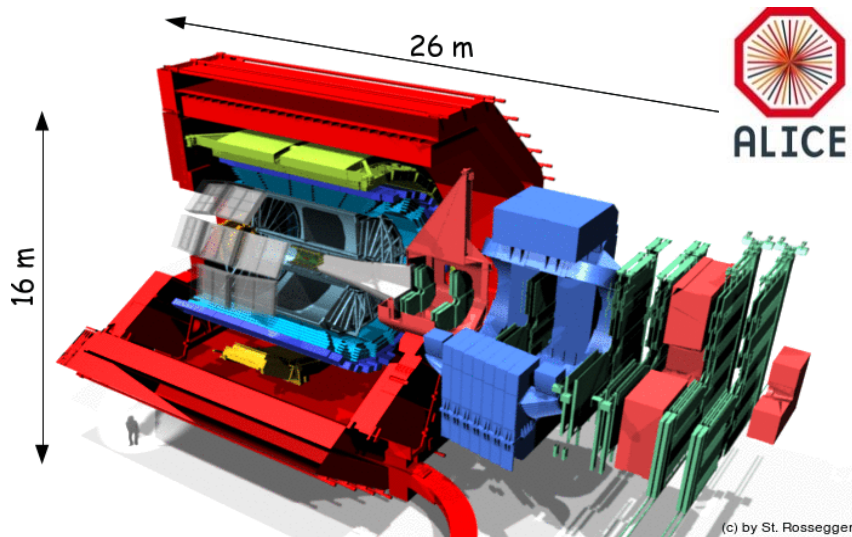

- High precision measurements of rare probes at low p_T , which cannot be selected with a trigger, require a large sample of events recorded on tape

$$(Pb-Pb) L_{int} \geq 10 \text{ nb}^{-1}$$

$$L = 6 \cdot 10^{27} \text{ cm}^{-2}\text{s}^{-1}$$

LS2 upgrades
Goal: Increase statistics

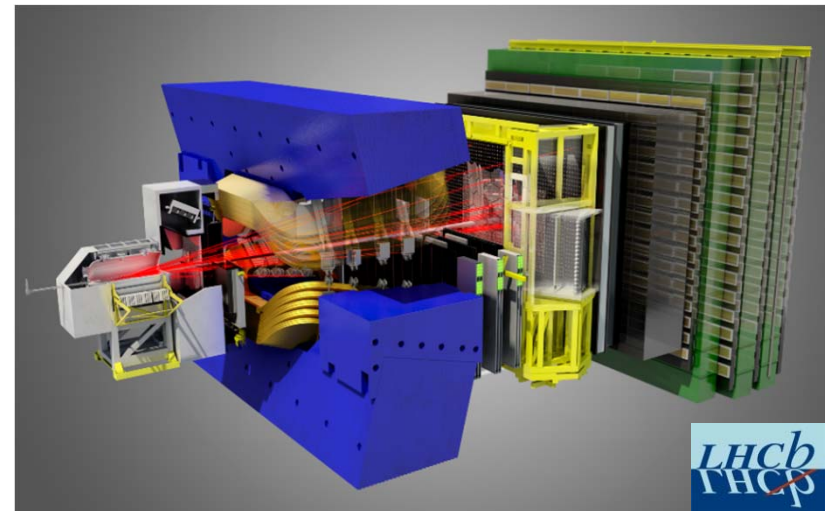

- Look for new physics hints in CP violation effects as well as in rare charm and beauty hadron decays.
- Enhance the experimental sensitivities (specially to hadron channels) to match theory prediction accuracy.

$$L_{int} \geq 50 \text{ fb}^{-1}$$

$$L > 10^{33} \text{ cm}^{-2}\text{s}^{-1}$$

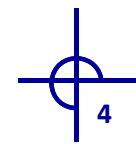

ALICE and LHCb



"Upgrade plans for LHC detectors"



Cristina Fdez. Bedoya

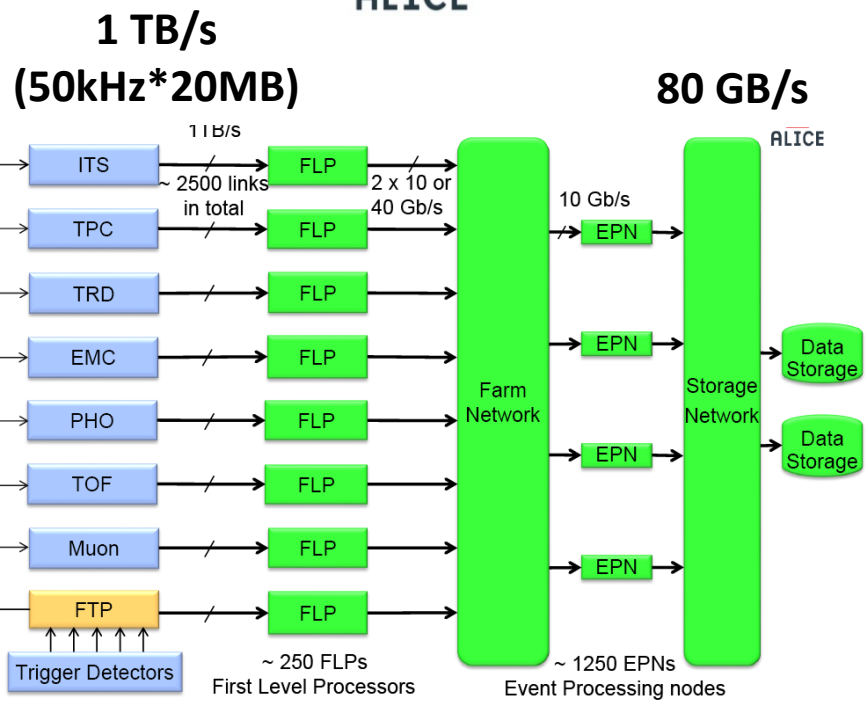

40 MHz architecture overview

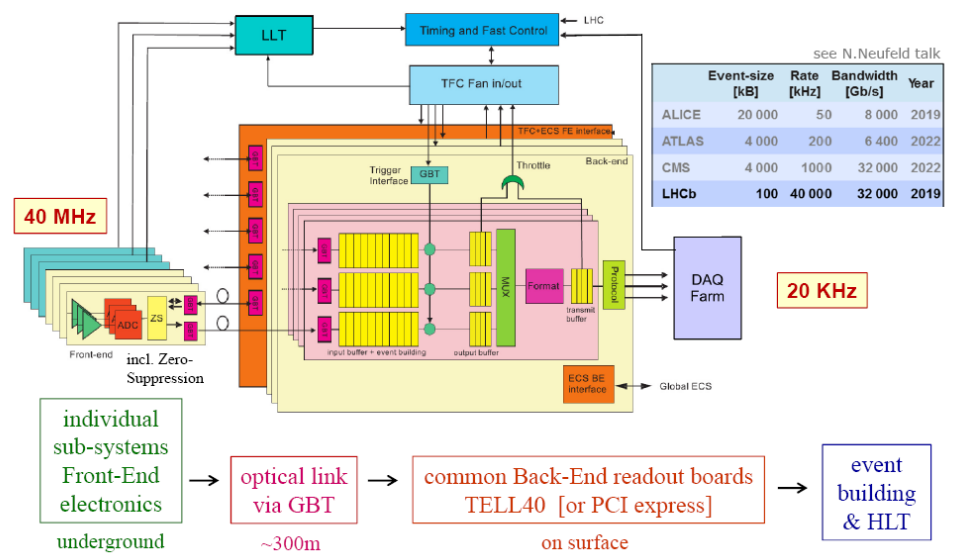

see N. Neufeld talk

	Event-size [kB]	Rate [kHz]	Bandwidth [Gb/s]	Year
ALICE	20 000	50	8 000	2019
ATLAS	4 000	200	6 400	2022
CMS	4 000	1000	32 000	2022
LHCb	100	40 000	32 000	2019

from 500 Hz to 50 kHz readout rate

- Upgrade electronics, online systems and offline reconstruction and analysis framework.
- Perform data reduction with reconstruction of clusters+tracks
- New computing system DAQ, HLT and offline

ALL sub-systems to 40 MHz Front-End electronics (triggerless)

- Replace the electronics of all the subsystems
- Trigger executed in the CPU farm: reduction to 20 kHz

ALICE O² upgrade

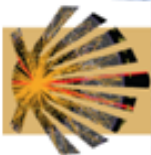

New Tracking Systems

ALICE

NEW BEAM PIPE

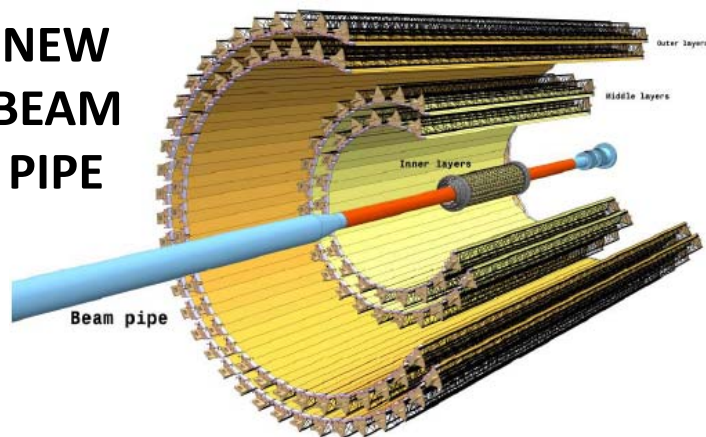

New Inner Tracking System (ITS)

- Improve vertexing and tracking at low p_T
- 7 layers monolithic pixel detector
- TowerJazz 180nm CMOS technology
- High granularity ($20 \times 20 \mu\text{m}^2$)
- low-mass sensors for the relative low radiation expected at an affordable cost

Muon forward tracker (Pixel)

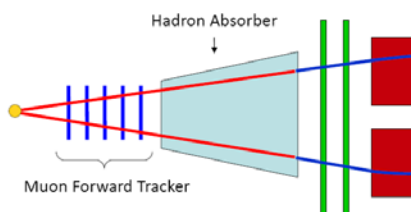

- near the vertex to improve background rejection and mass resolution of the ALIC muon system

LHCb

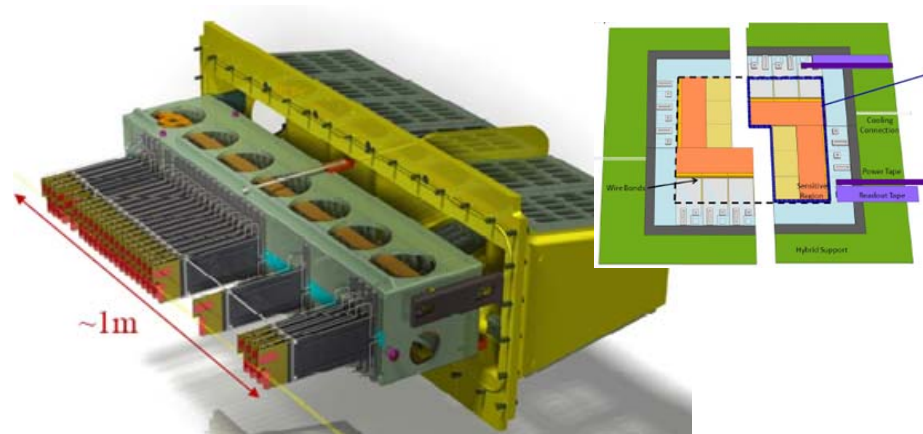

New VELO

- Increased radiation tolerance
- Higher granularity: $55 \times 55 \mu\text{m}^2$ pixel sensors (based on Timepix)
- Novel microchannel CO_2 cooling
- Data driven readout at 40 MHz \rightarrow $> 2 \text{Tbits/s}$ from the whole VELO

Upstream Tracker

Adapt segmentation to occupancies

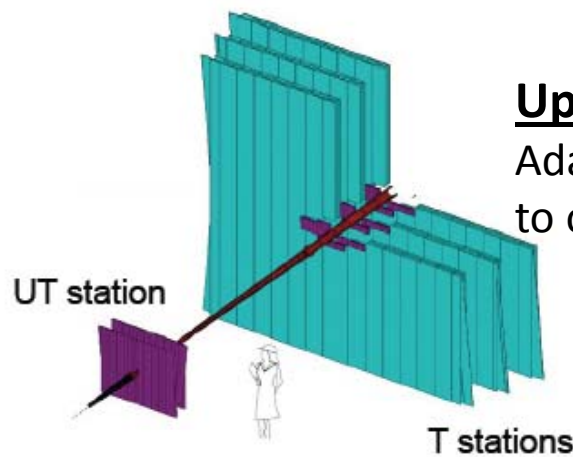

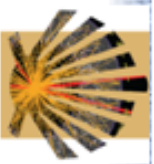

T-stations upgrade: Fibre Tracker (FT)

"Upgrade plans for LHC detectors"



Cristina Fdez. Bedoya

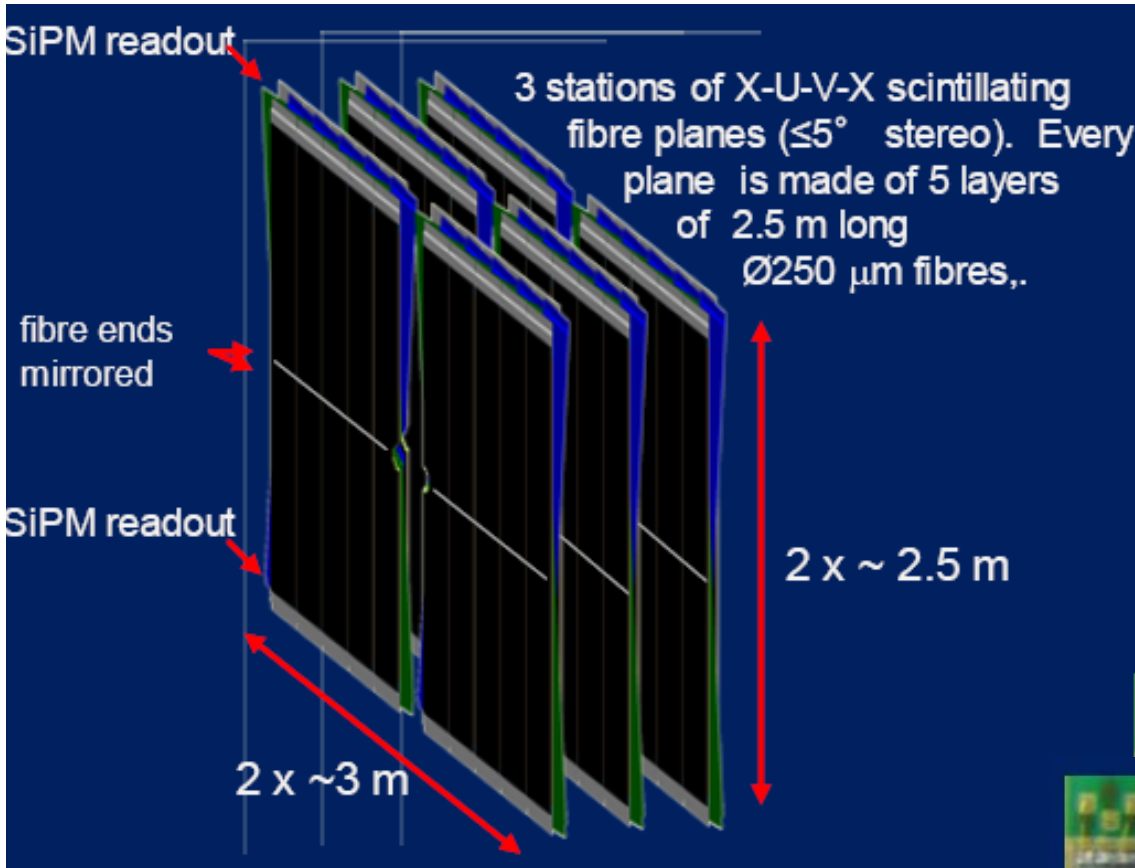

- 250µm diameter scintillating fibers 2.5m long
- SiPM readout (must be cooled to -40°C for noise reduction)
- Fiber inner ends will experience up to 22 kGy
- High hit detection efficiency and fast pattern recognition

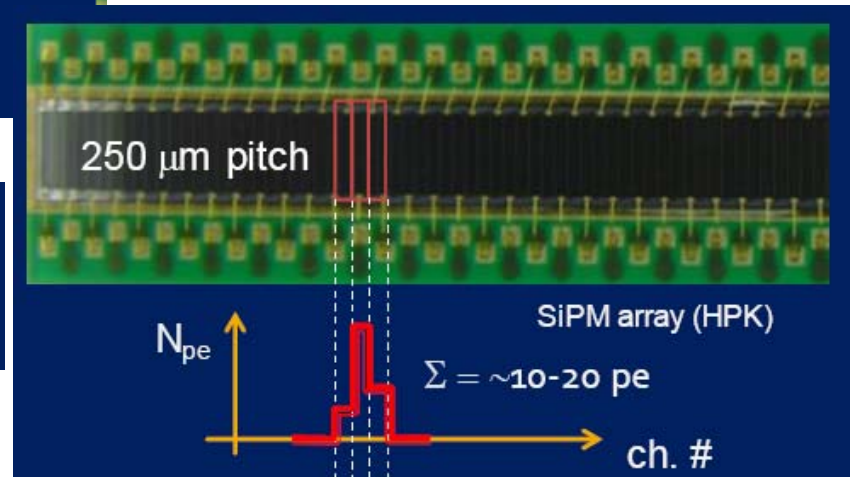



TPC Upgrade

GEMs

- Will be used in many detectors
- Excellent rate capability: up to $10^5/\text{cm}^2$
- Gas mixture: Ar/CO₂/CF₄ – not flammable
- Large areas $\sim 1 \text{ m} \times 2 \text{ m}$ with industrial processes

TPC Upgrade with GEMs

Replace wire chambers
With quadruple-GEM chambers

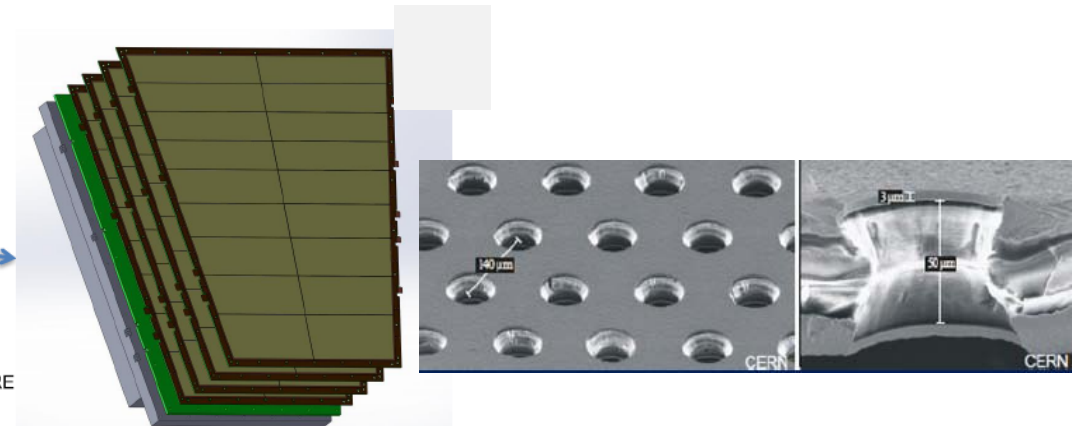
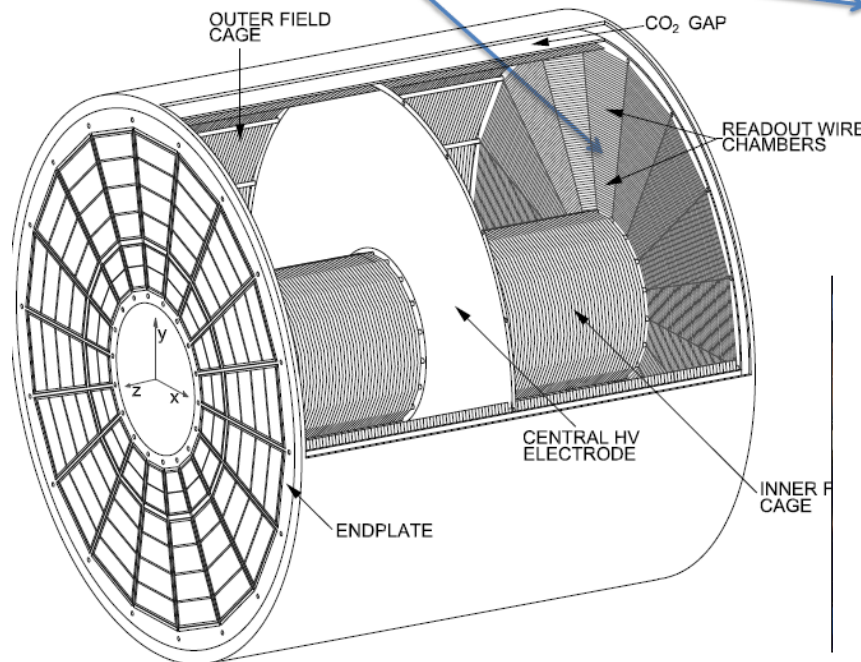

- Ion feedback => MWPC not compatible with 50 kHz operation (max readout rate $\sim 3.5 \text{ kHz}$)
- New pipelined readout electronics

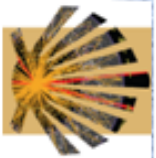

ATLAS and CMS



“Upgrade plans for LHC detectors”



Cristina Fdez. Bedoya

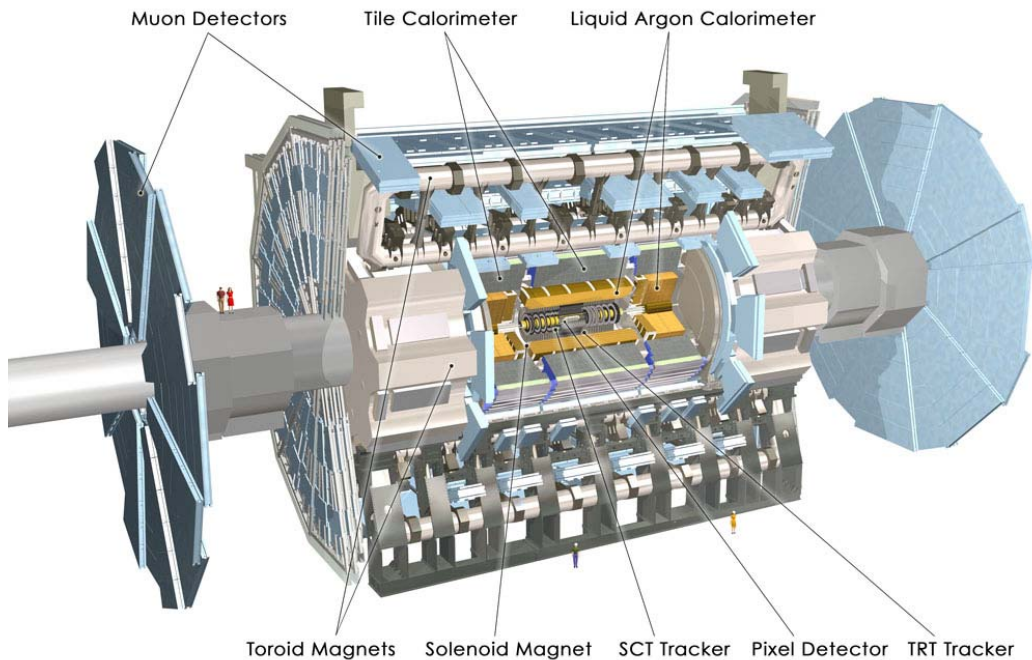

From LS1 to LS3:

- $2 * 10^{34} \text{ cm}^{-2}\text{s}^{-1}$
- PU ~ 50
- 300 fb^{-1}

Beyond LS3:

- $5 * 10^{34} \text{ cm}^{-2}\text{s}^{-1}$
- (with lumi-leveling)
- PU ~ 140
- 3000 fb^{-1} ($250 \text{ fb}^{-1}/\text{year}$)

Full upgrade program to cope with increasing luminosity:

Radiation damage, pile-up mitigation, bandwidth limitations, aging...

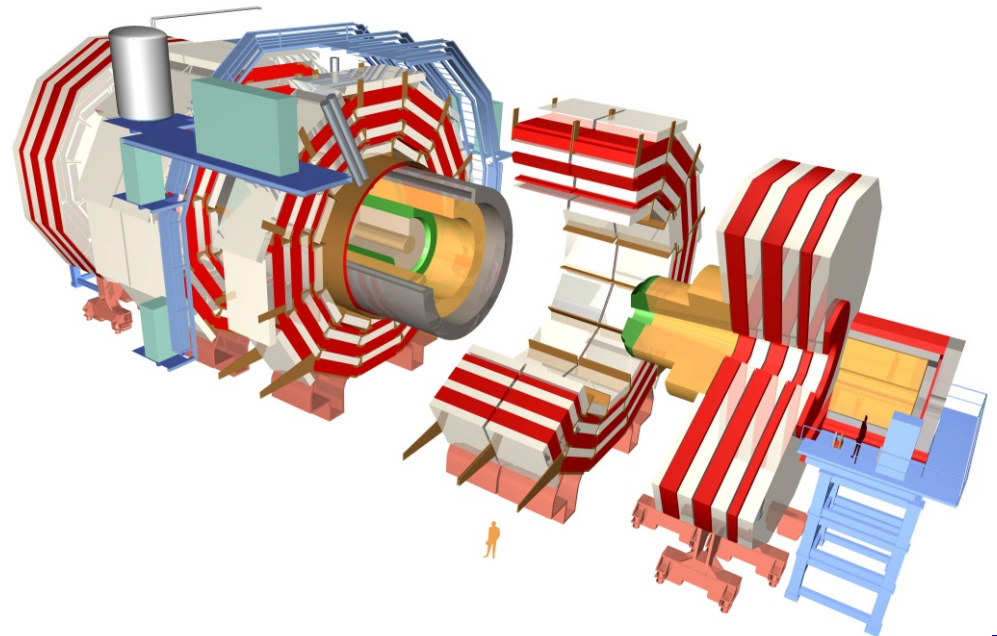

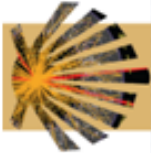

ATLAS and CMS Pixels

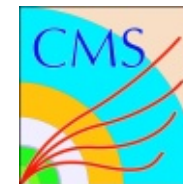

New Insertable B-layer (IBL) in LS1

- Average radius of 3.3 cm
- Pixel size (50mmx250mm) compared to the present 50mmx400mm
- Thin planar sensors and 3D double side sensors
- Reduce the fake tracks arising from random combinations of hits and enhance efficiency of tagging heavy flavour quarks

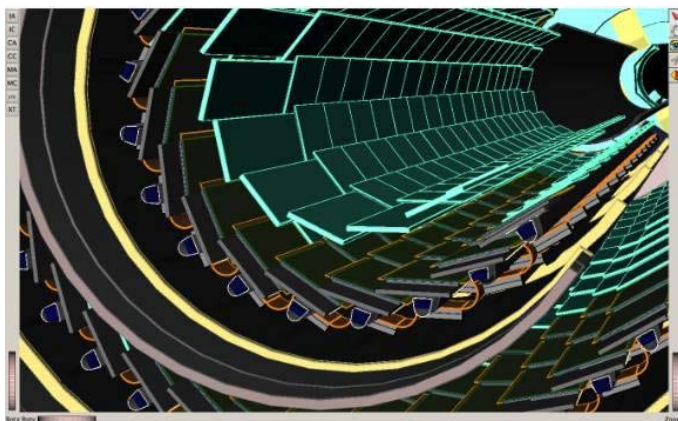

New Pixel in 2017

- New beam pipe in LS1
- 4 layers/3 disks
- 3 cm inner radius
- New readout chip: recovers inefficiency at high rate and PU
- Significantly reduced material budget
- CO₂ cooling, DC-DC powering scheme
- Improved track resolution and efficiency
- Improved vertex resolution and b-tagging

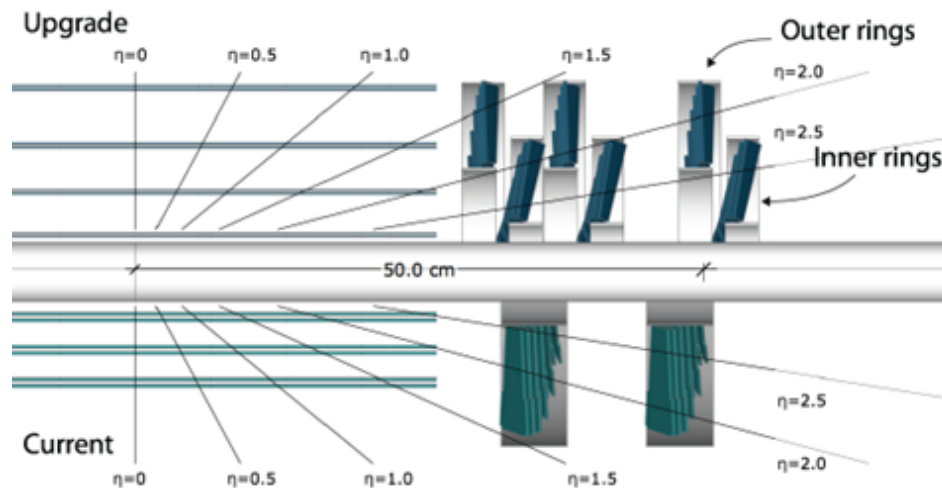



ATLAS and CMS Phase 1 Trigger



Increase of luminosity forces upgrading present system in order to control the rates maintaining similar thresholds already before LS3

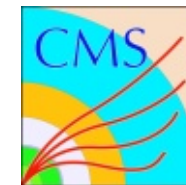

"Upgrade plans for LHC detectors"

High Precision L1 Calorimeter Trigger

- Readout of super-cells in LAr with higher granularity and higher precision

Fast Tracking (FTK) for the Level-2 trigger

- Finds and fits tracks (~ 25 μs) in the ID silicon layers at an "offline precision"

hit pattern matching to pre-stored patterns (coarse)

subsequent linear fitting in FPGAs (precise)

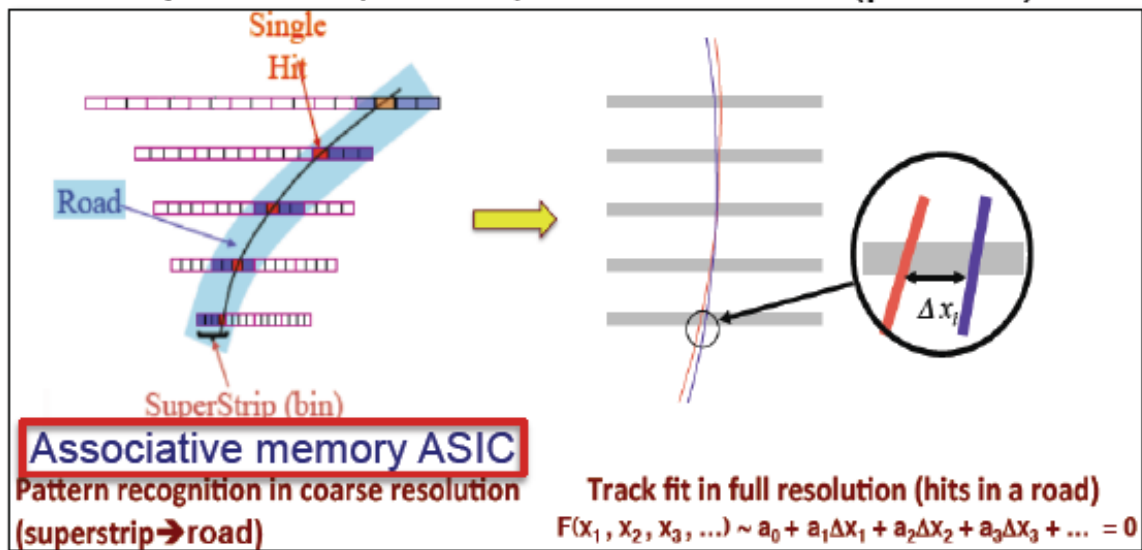

New Level1 back-end electronics

- Upgrade of the off-detector electronics using uTCA technologies:
- Powerful FPGAs and high bandwidth optics
- Allows much improved algorithms for PU mitigation and isolation
- Improve L1 Trigger capabilities to cope with higher rates

uTCA boards

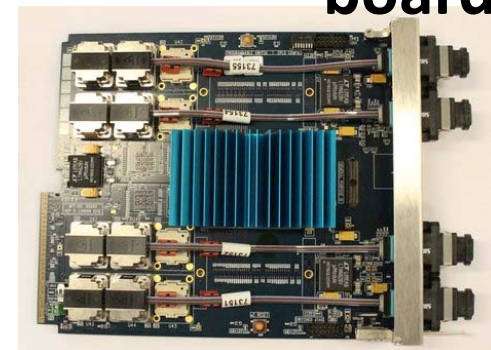

Cristina Fdez. Bedoya

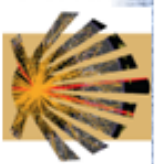

ATLAS and CMS Muons



LS1 upgrades:

End-cap Extension (EE) MDT
- coverage at $1.0 < |\eta| < 1.3$

Existing detectors are expected to cope with HL-LHC radiation and luminosity, but much of the electronics may be replaced due to trigger needs.

New Small Wheel (NSW) in LS2

- **Micromegas & sTGC :**
precision measurement and trigger
- First large system based on Micromegas
- Finer granularity
- Resistive strips for spark immunities
- 'Floating mesh' configuration
- Good spatial resolution also for inclined tracks thanks to μ TPC operation mode

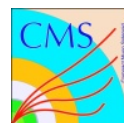

- **New stations** to improve redundancy in the most complicated region:
GEMs and GRPC or iRPC
- Extension to $\eta \sim 4$ (ME0)?
- R&D in new gas mixtures

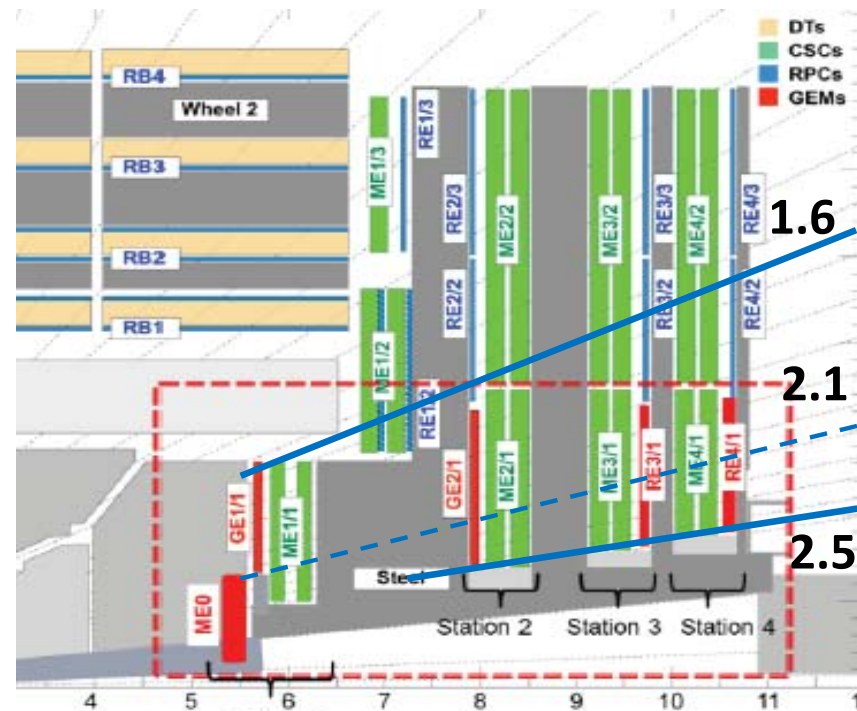
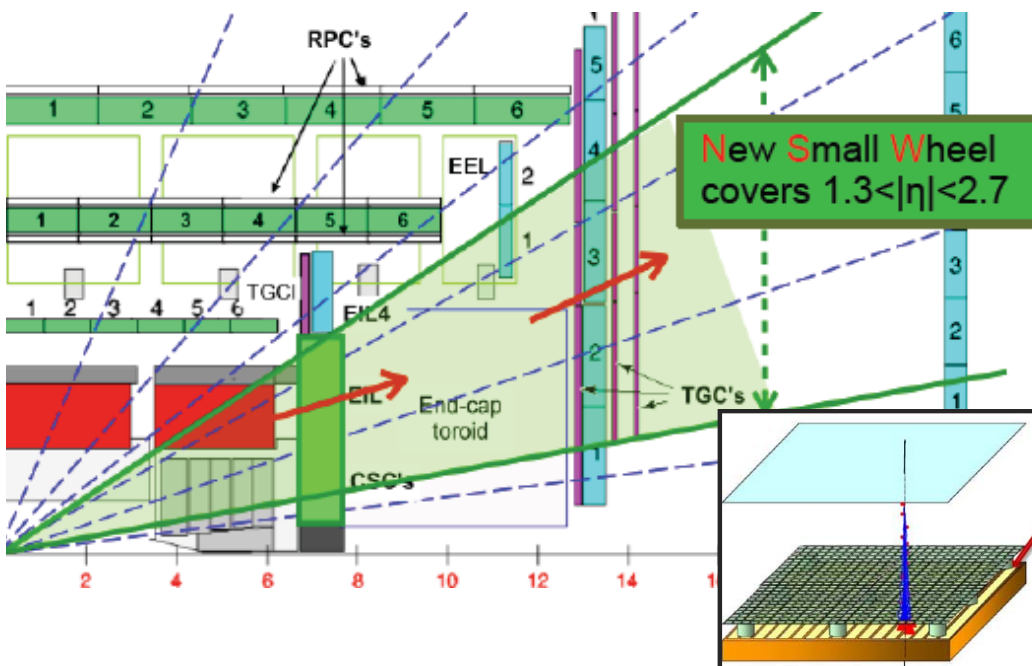

- New **DT barrel electronics** to allow higher trigger rate

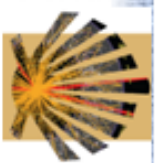

ATLAS and CMS Calorimetry Electronics



Tile and LAr electronics in LS3

- Replacement due to ageing and radiation tolerance
- Limited on-detector pipelines prevent application of more advanced trigger algorithms
- On-detector digitization of all signals at 40 MHz
- Radiation tolerant chips on detector
- ATCA technology in the back-ends

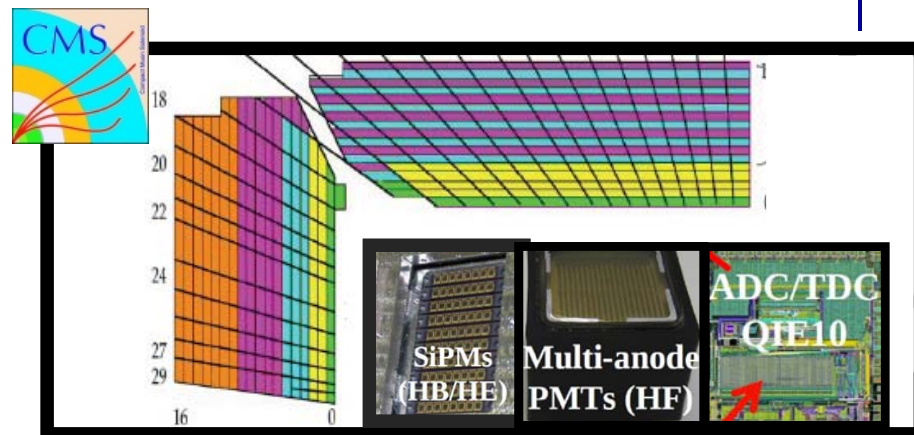
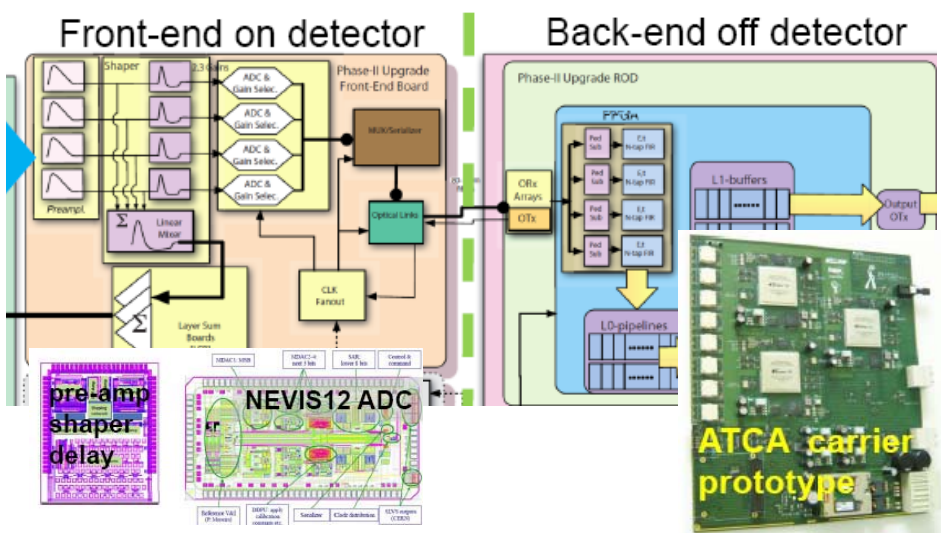

HCAL electronics in LS2

- replaced to improve system performance: reduce noise, increase depth segmentation and allow timing measurement

ECAL barrel electronics in LS3

- to accommodate to higher trigger rates and latency
- Implement a 40 MHz continuous read-out

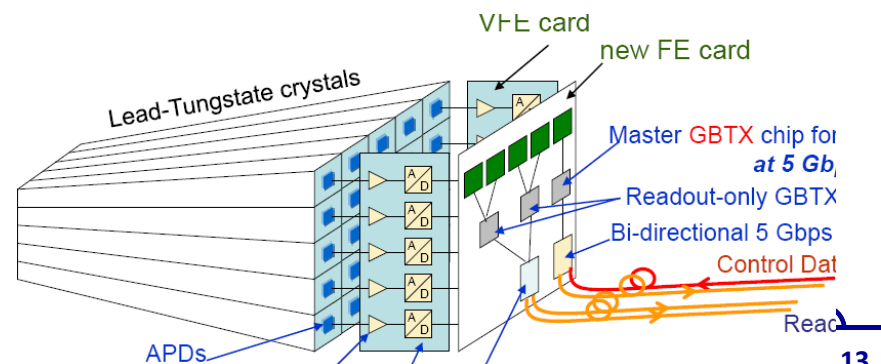

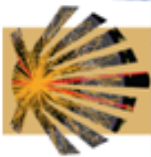

ATLAS and CMS Calorimetry

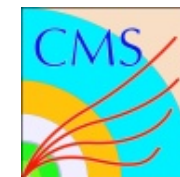

The ATLAS & CMS Barrel calorimeters are sufficiently rad-hard to operate through Phase II

- End-Cap LAr is intrinsically radiation hard
- Lar Hadron End-Cap Calorimeter (HEC) cold electronics is under evaluation: replacing this would necessitate opening of the cryostat
- LAr FCAL may suffer and may need replacement (under study)

EndCap ECAL and Endcap HCAL

need to be replaced in LS3 due to radiation degradation.

Two options:

1- Maintain present subdivision in more radiation tolerant designs

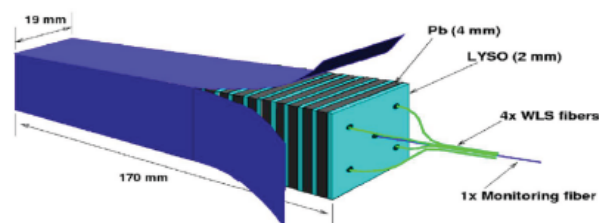

Shashlik EE towers (crystal scintillator: LYSO, CeF)

HE with rad-hard fibers

2- Integrated calorimeters with adequate electromagnetic resolution and significantly improving hadronic resolution and jet response

-Dual fiber read-out: scintillation & Cerenkov (DROC) (DREAM/RD52)

-Particle Flow Calorimeter (PFCAL) CALICE, with GEM/Micromegas

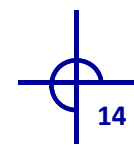
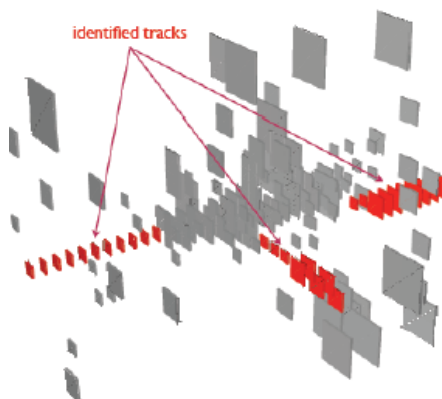

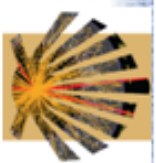

ATLAS and CMS Phase 2 Tracker



Tracker (and pixel) of both ATLAS and CMS need to be rebuilt in LS3 due to radiation damage

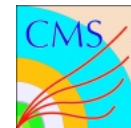

Novel technologies will improve:

- Tracking reconstruction efficiency, transverse momentum and impact parameter resolution
- Minimize amount of material in the tracker volume
- Inner volumes up to $10^{16} \text{cm}^{-2} n_{\text{eq}}$
- Both consider extension to $\eta \sim 4$
- Both will contribute to the Level-1 trigger (\uparrow purity of trigger, what is done in **SW** \rightarrow **HW**):
 - ATLAS: Region of interest with a Level-0
 - CMS: p_t modules to discard signals $p_t < 2 \text{ GeV}$

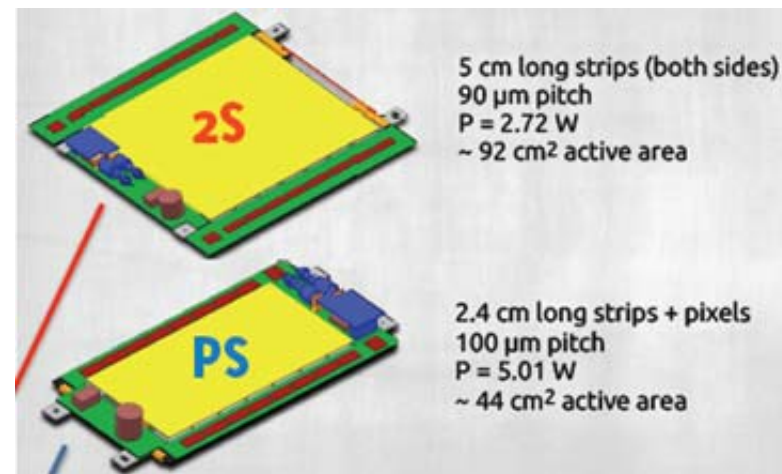

Lol layout new (all Si) ATLAS Inner Tracker for HL-LHC

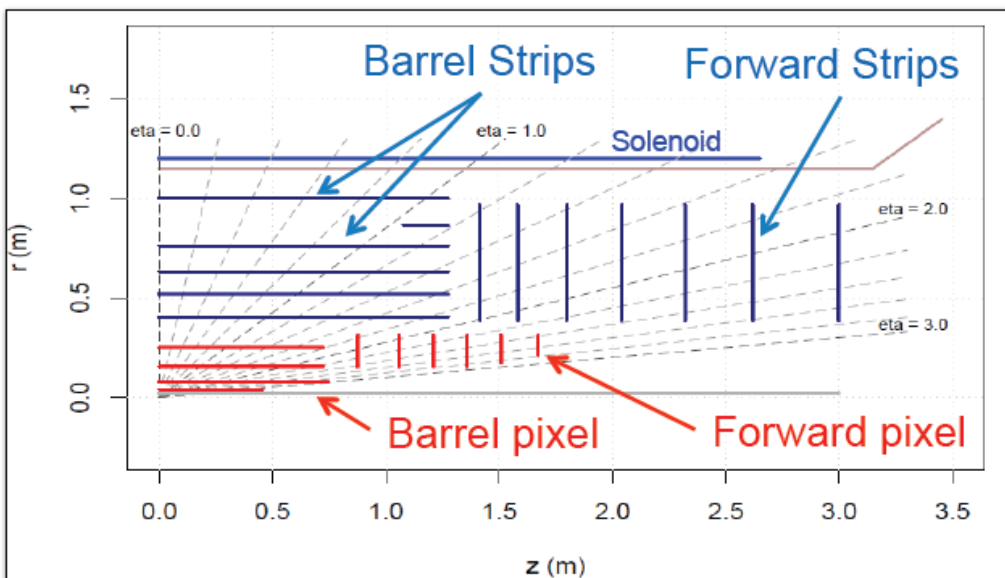

Trigger track selection in FE

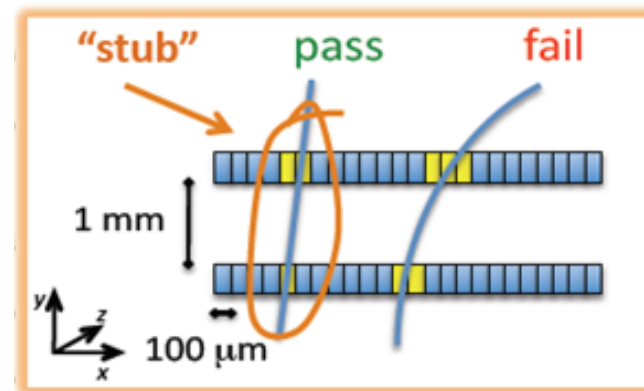

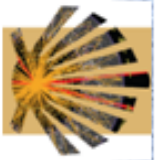

ATLAS and CMS Trigger and DAQ



Increase of luminosity forces upgrading present system in order to control the rates maintaining similar thresholds



Level-0
Rate ~ 500 kHz, Lat. ~6 μ s
Muon + Calo

Level-1
Rate ~200 kHz, Lat. ~20 μ s
Muon + Calo + Tracks

New L0/L1 trigger

- “Pull” option
- L0 uses:
 - Calo. & μ Triggers
- L1 uses:
 - Track Trigger & more μ detectors & more fine grained calo.
- HLT output rate of 5 - 10 kHz

- Only one level of HW trigger
- “Push” option
- L1 uses:
 - Track Trigger, finer granularity μ & calo.
- HLT output rate of 10 kHz
- Impact on EB and DT electronics

L1 latency from 3 μ s \rightarrow 10 μ s (20 μ s?)

L1 rate from 100 kHz \rightarrow 500kHz-1 MHz

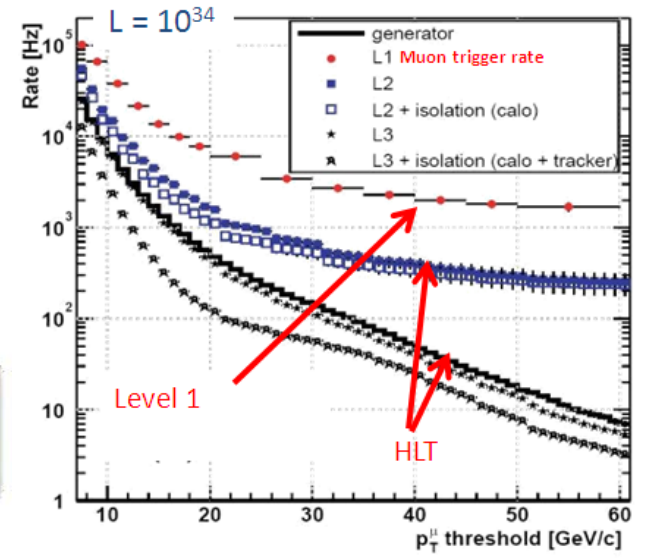
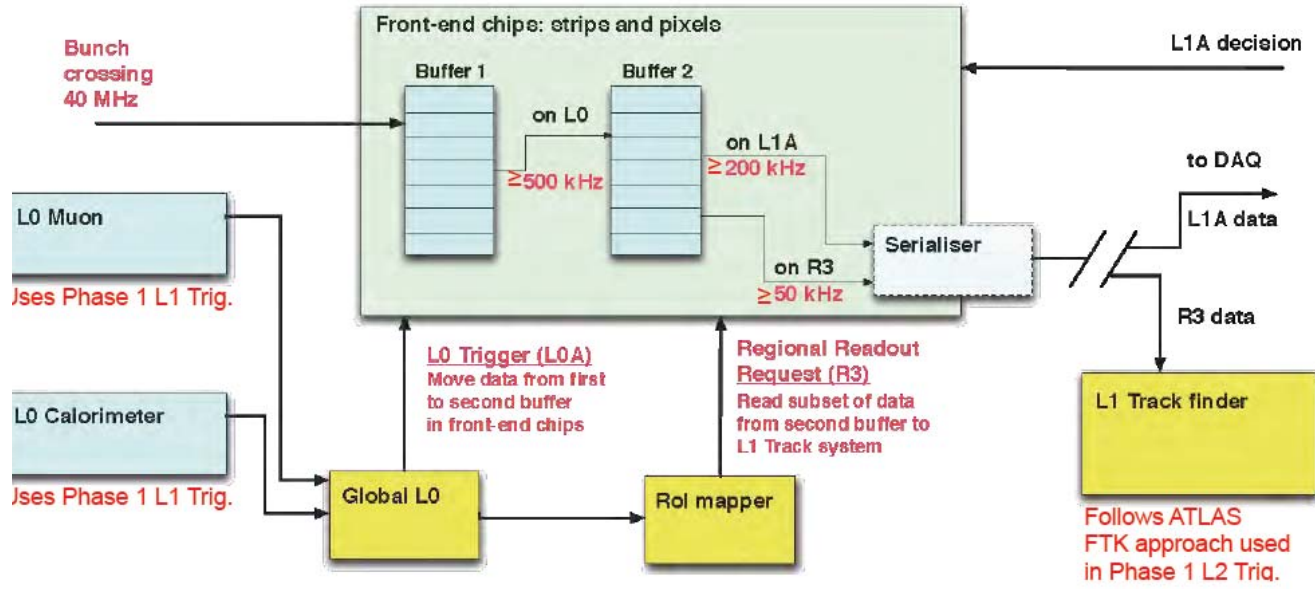

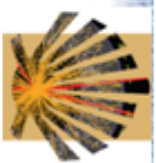

LHC schedule

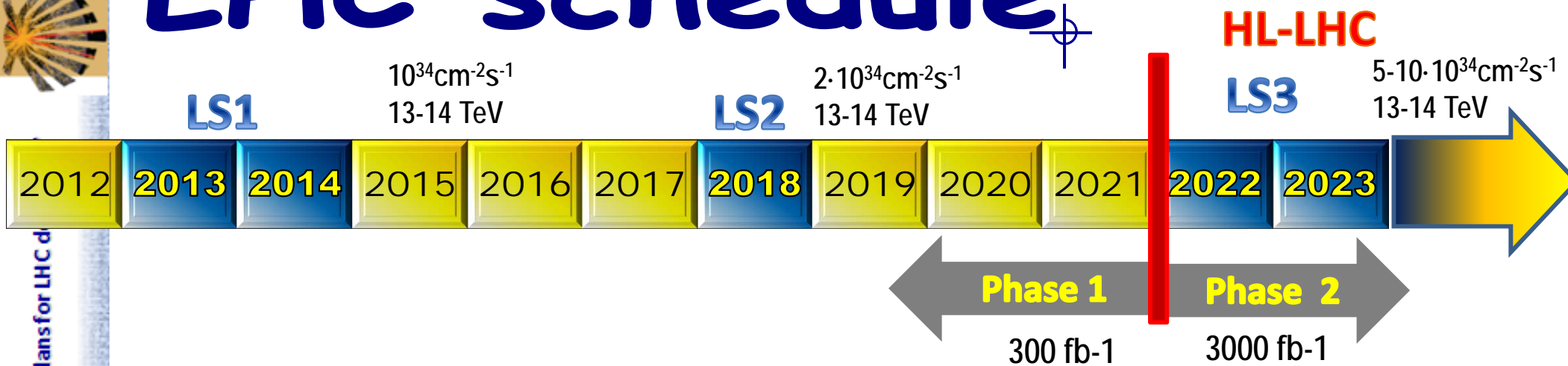

"Upgrade plans for LHC d



Cristina Fdez. Bedoya

	LS1	2016-17	LS2	LS3
ATLAS	New inner pixel layer Muon extension		Trigger upgrade (L2 FTT), MSW	New Tracker New trigger L0/L1 Muon and calorimeter electronics
CMS	Muon forward HF and HO photodetectors	Pixel	HCAL electronics	New Tracker EE and HE replacement New Muon stations and electronics
ALICE	-	-	Readout 50 kHz. ITS, TPC, MFT	-
LHCb	-	-	Readout 40 MHz. VELO, RICH, Tracking	-

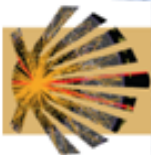

R&D collaborations

Common initiatives that foster developments across experiments

Tracking systems:

- RD42 "Development of Diamond Tracking Detectors for HL-LHC"
- RD50 "Radiation hard semiconductor devices for very high luminosity colliders"
- "Forum on Tracking Detector Mechanics 2013"

Calorimetry

- RD52 "Dual Read-out Calorimetry"
- CALICE collaboration

Muon systems

- RD51 "Micro-Pattern Gas detectors Technologies"

Electronics

- Common Electronics Projects (GBT), ACES
- RD53 "Development of pixel readout integrated circuits for extreme rate and radiation"

Trigger/DAQ/Offline/Computing

- TDAQ teams from experiments
- PH-SFT group

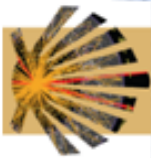

Spanish participation to LHC Upgrades



"Upgrade plans for LHC detectors"



Cristina Fdez. Bedoya



Upgrade of the ATLAS IBL Pixel

IFAE
IMB-CNM-CSIC

Upgrade of the AFP (forward detector silicon roman pot) at ATLAS

IFAE

Upgrade of the ATLAS forward tracker

IMB-CNM-CSIC
IFIC

Upgrade of the ATLAS TileCal

IFIC
IFAE



Upgrade of the CMS Drift Tubes

CIEMAT

Upgrade of the CMS Tracker (Pixels phase 2)

IFCA
ITA
INTA
IMB-CNM-CSIC

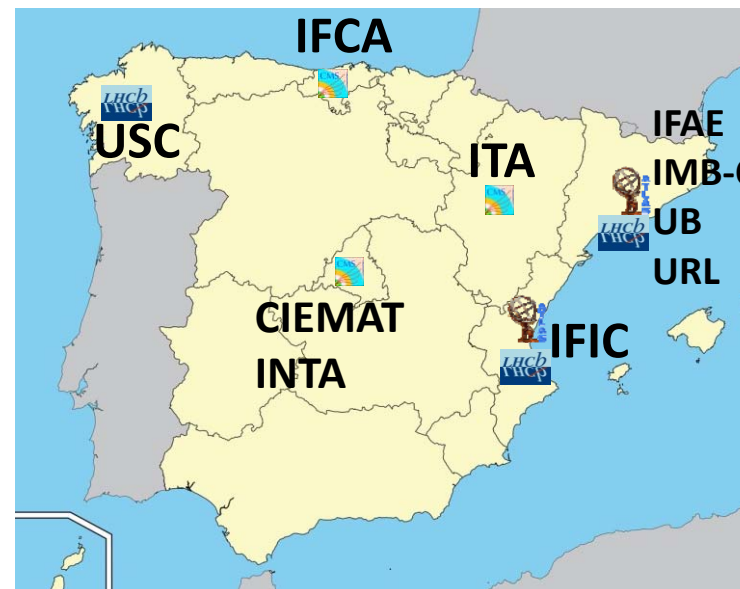

Upgrade of the LHCb velo
USC

Upgrade of the LHCb SciFi
UB (Universitat de Barcelona)
IFIC

Upgrade of the LHCb Calorimeter FE
UB
IFIC
URL (La Salle - Universitat Ram3n Llull)

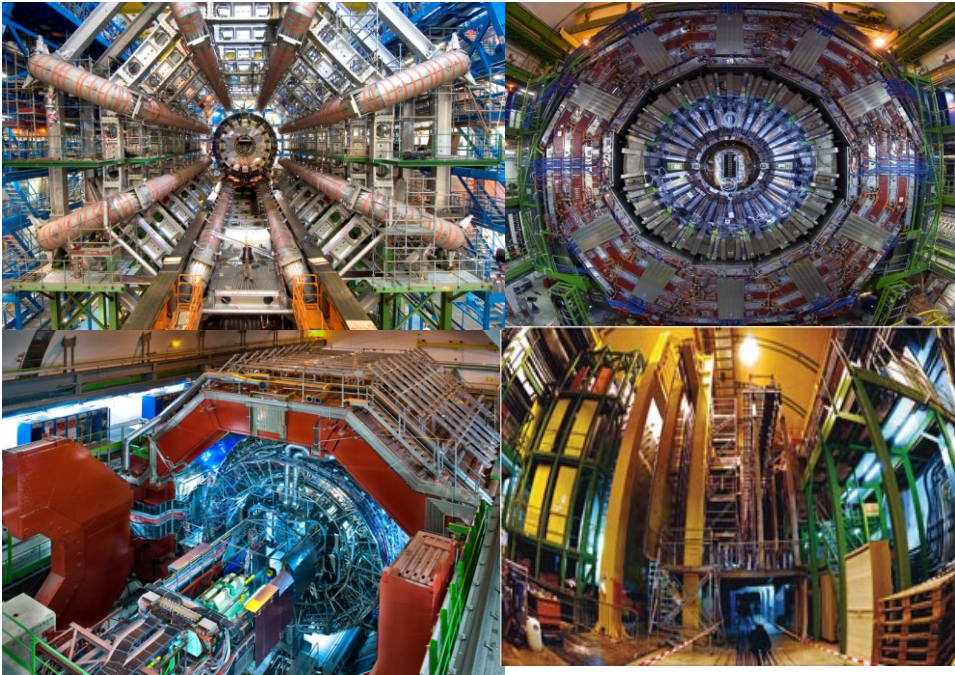

Thank you!

“Upgrade of the LHC detectors”

Cristina Fernández Bedoya