

# The Tau Air-Shower Mountain-Based Observatory

Jeff Lazar

IFIC Topical Seminar

Valencia, Spain

13 Mar., 2024



# How Does the Sun Shine ?

Charles Darwin

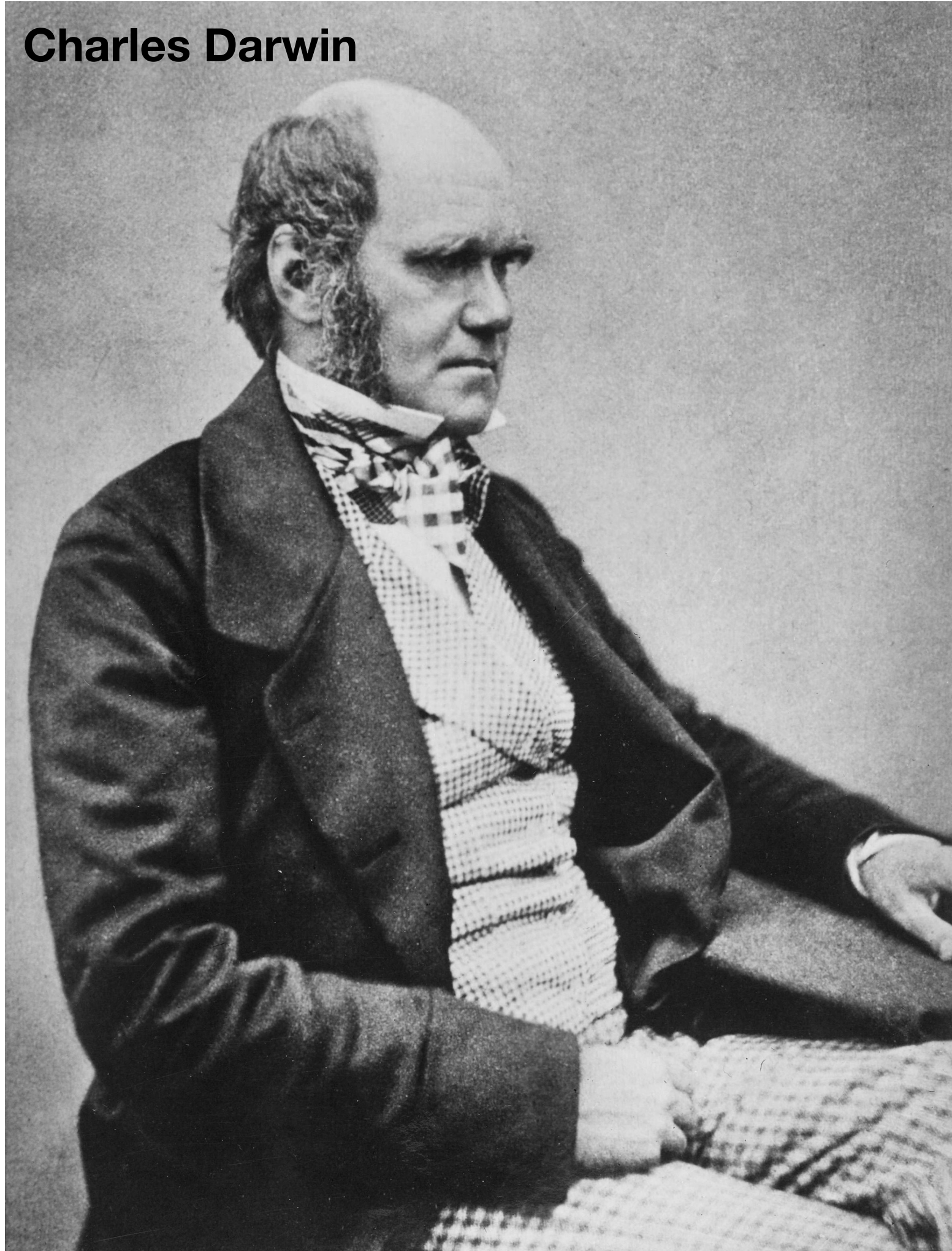

William Thomson

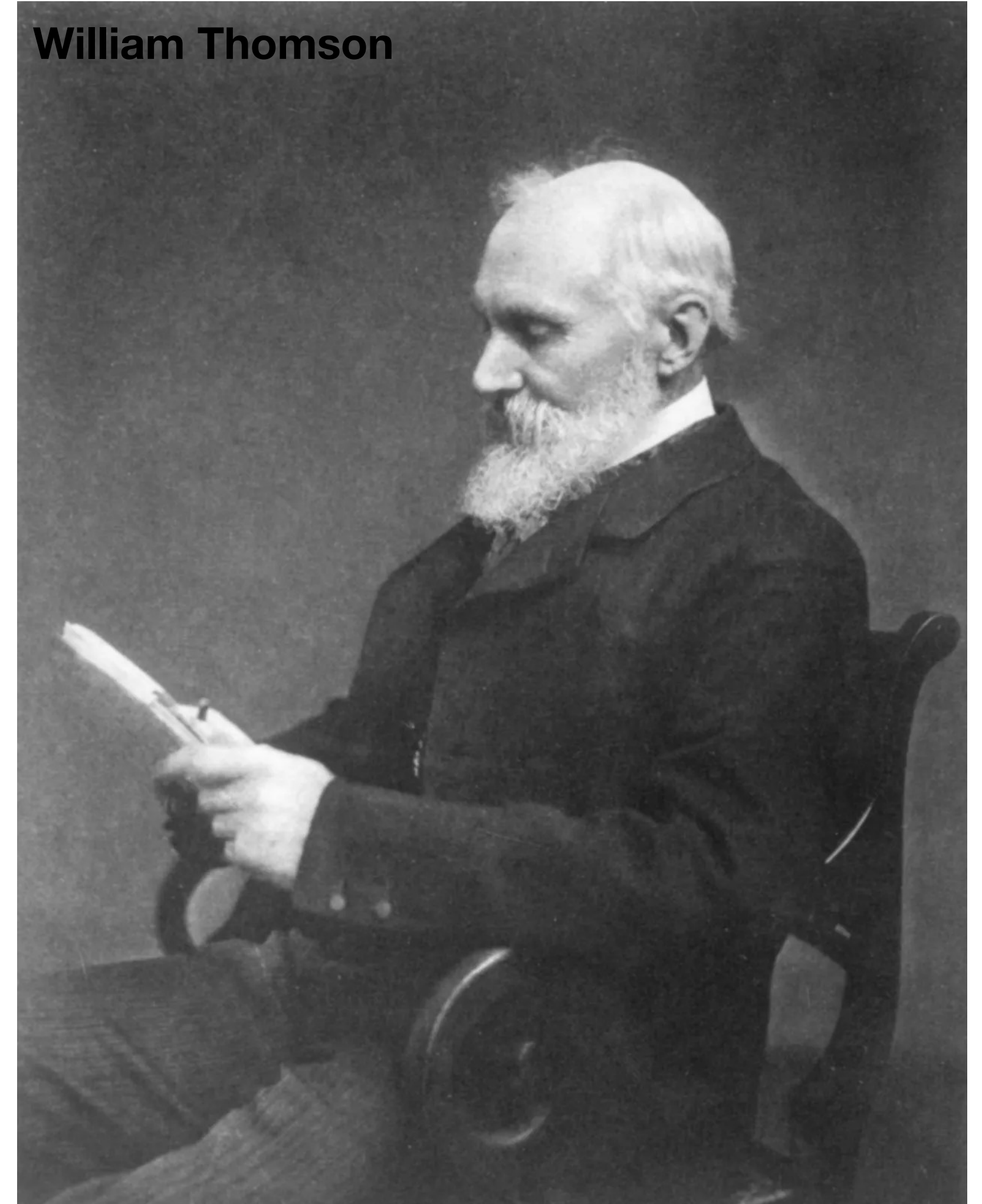

# How Does the Sun Shine ?

Charles Darwin

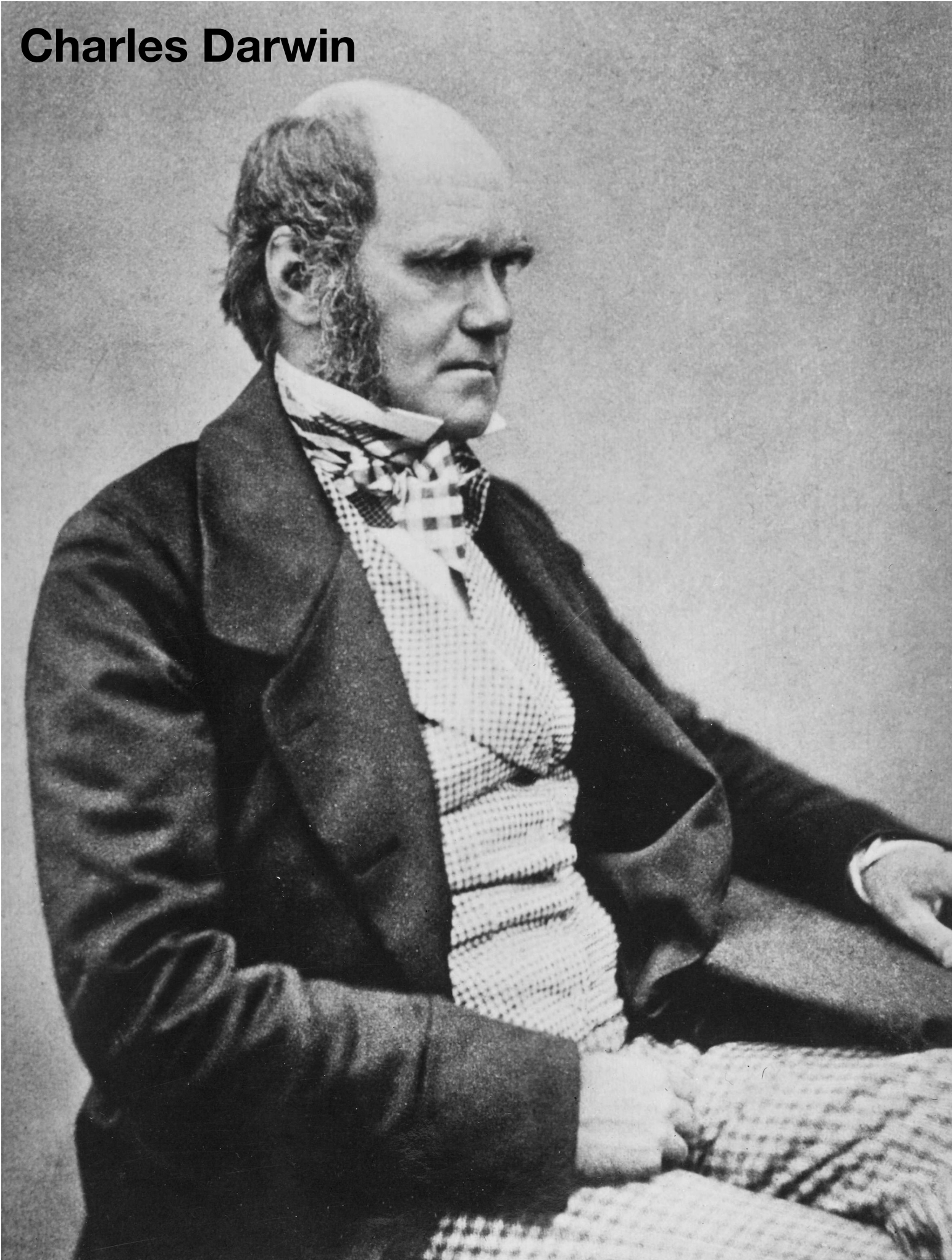

The Earth would need to exist for 300,000,000 years to give rise to the diversity of species I've observe. My observations of erosion in the Weald seem to support such a timeline.

William Thomson

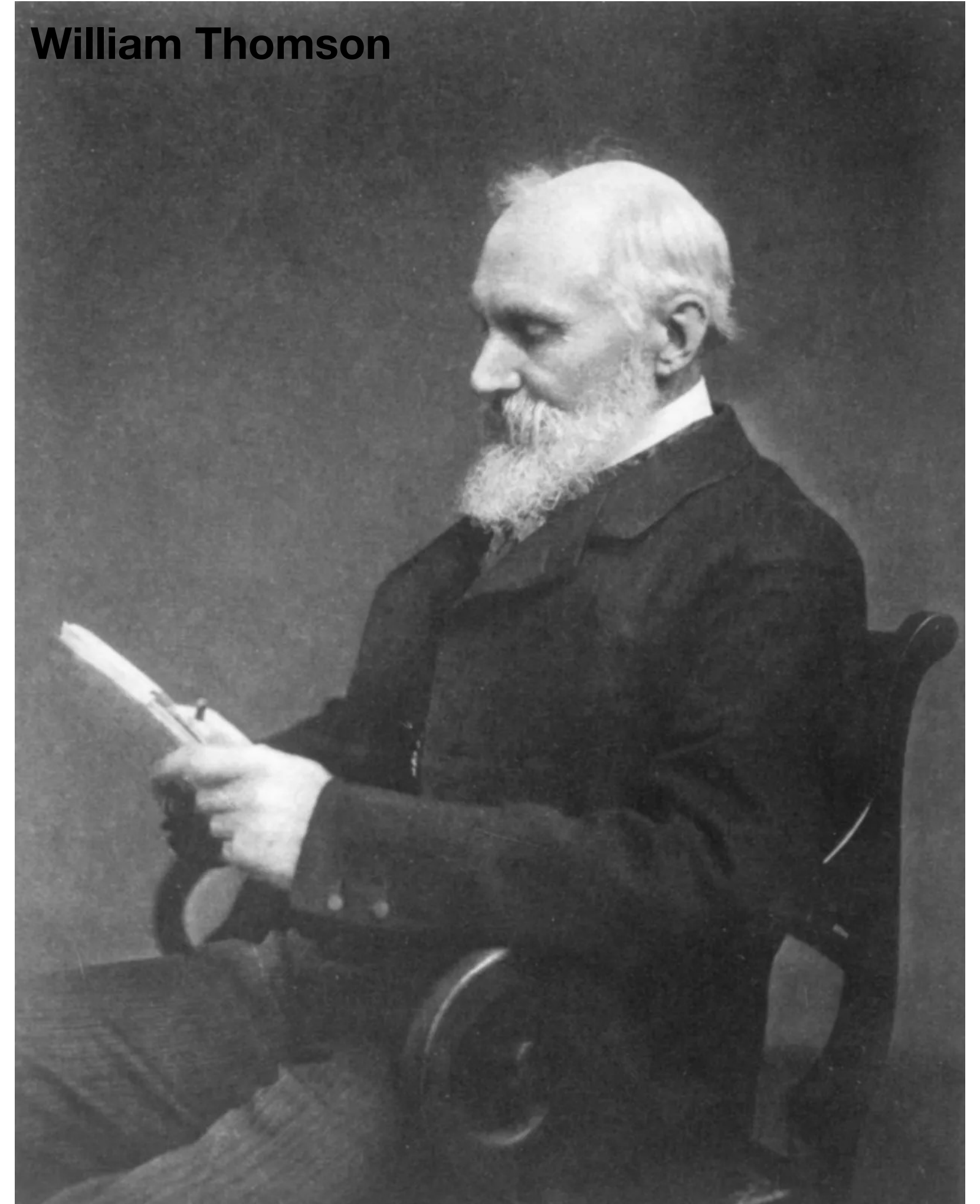

# How Does the Sun Shine ?

Charles Darwin

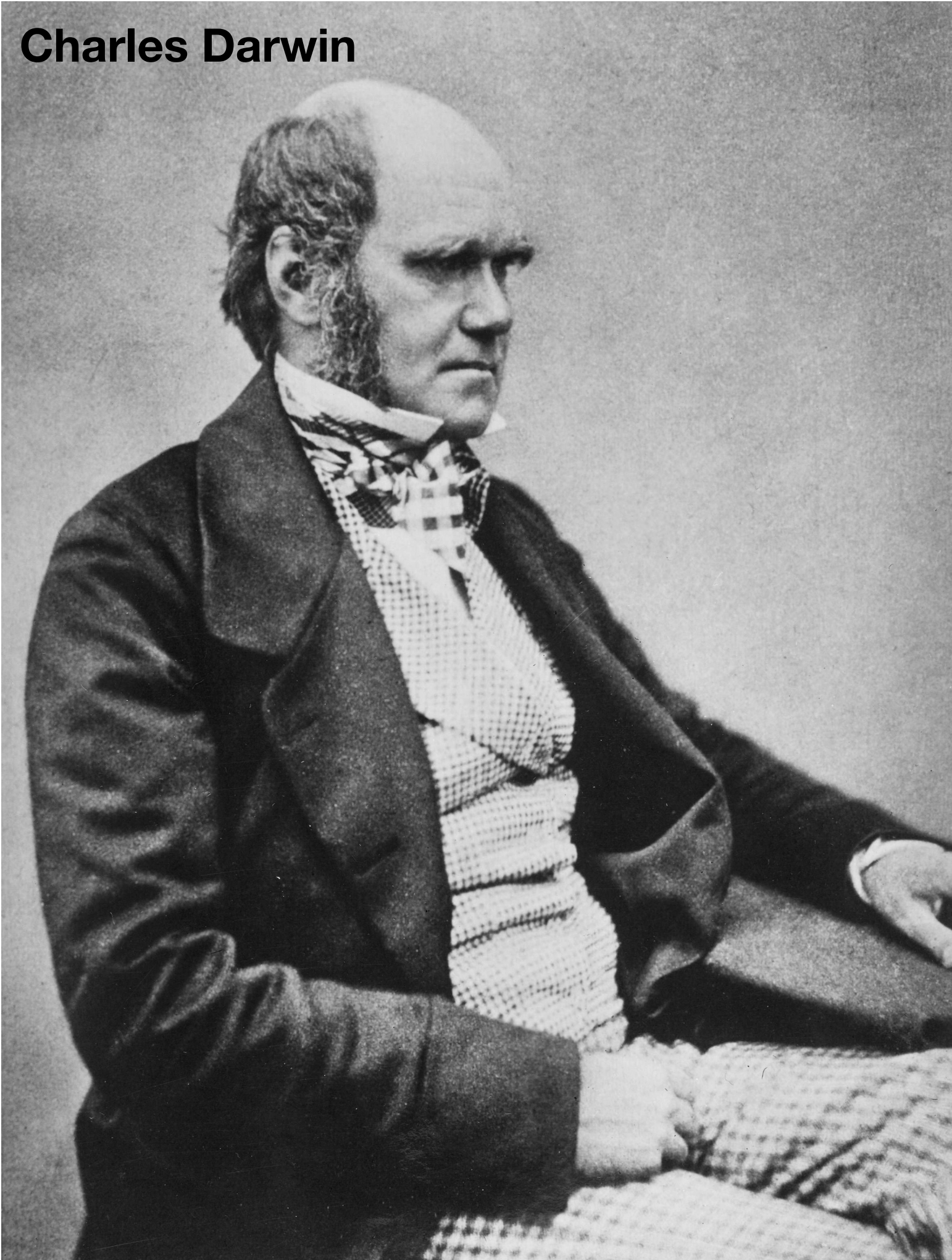

The Earth would need to exist for 300,000,000 years to give rise to the diversity of species I've observe. My observations of erosion in the Weald seem to support such a timeline.

This can't be ! Chemical processes could only power the Sun for 30,000 years and gravitational processes are still well-short.

William Thomson

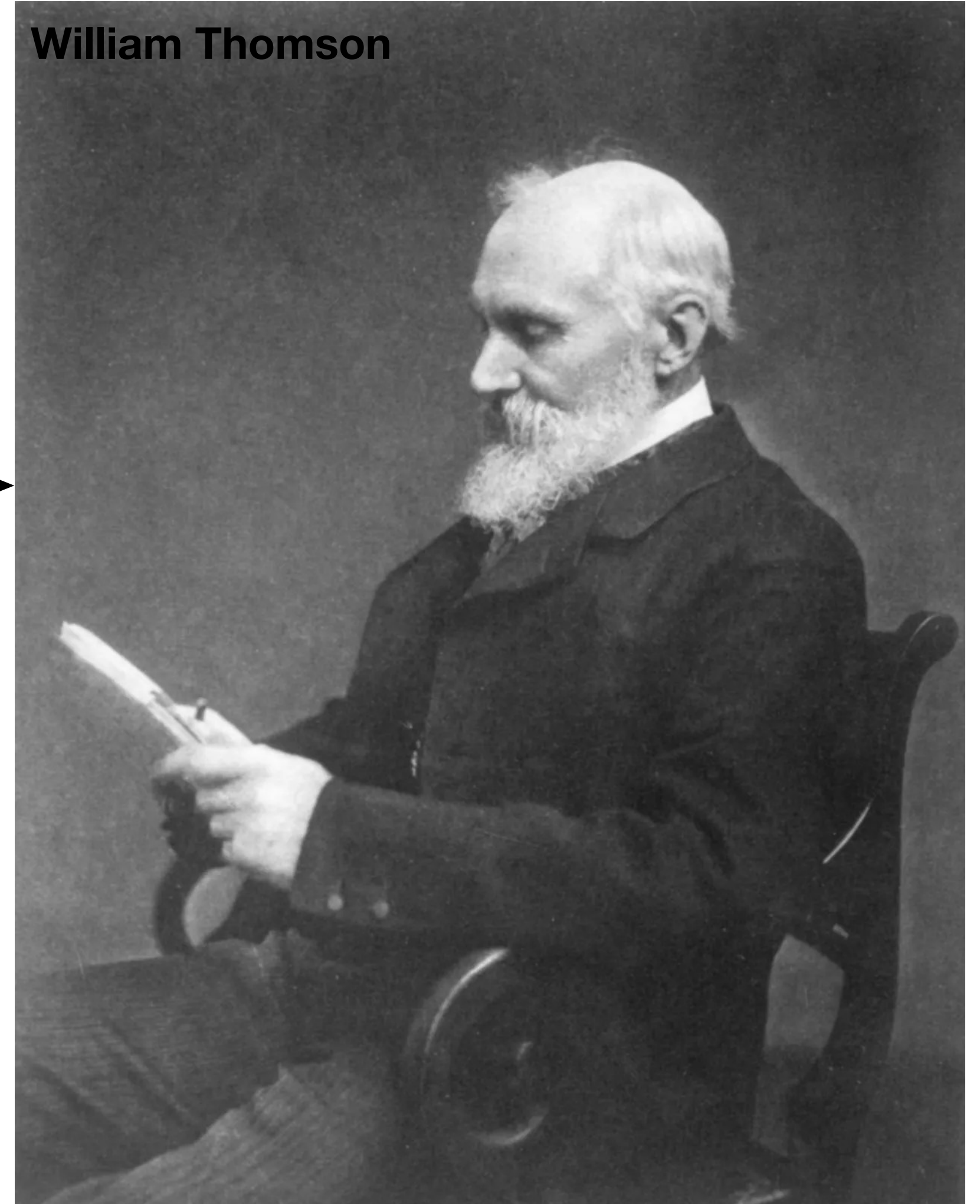

# How Does the Sun Shine ?

If the Sun generates energy from nuclear fusion, it will emit **electron** neutrinos

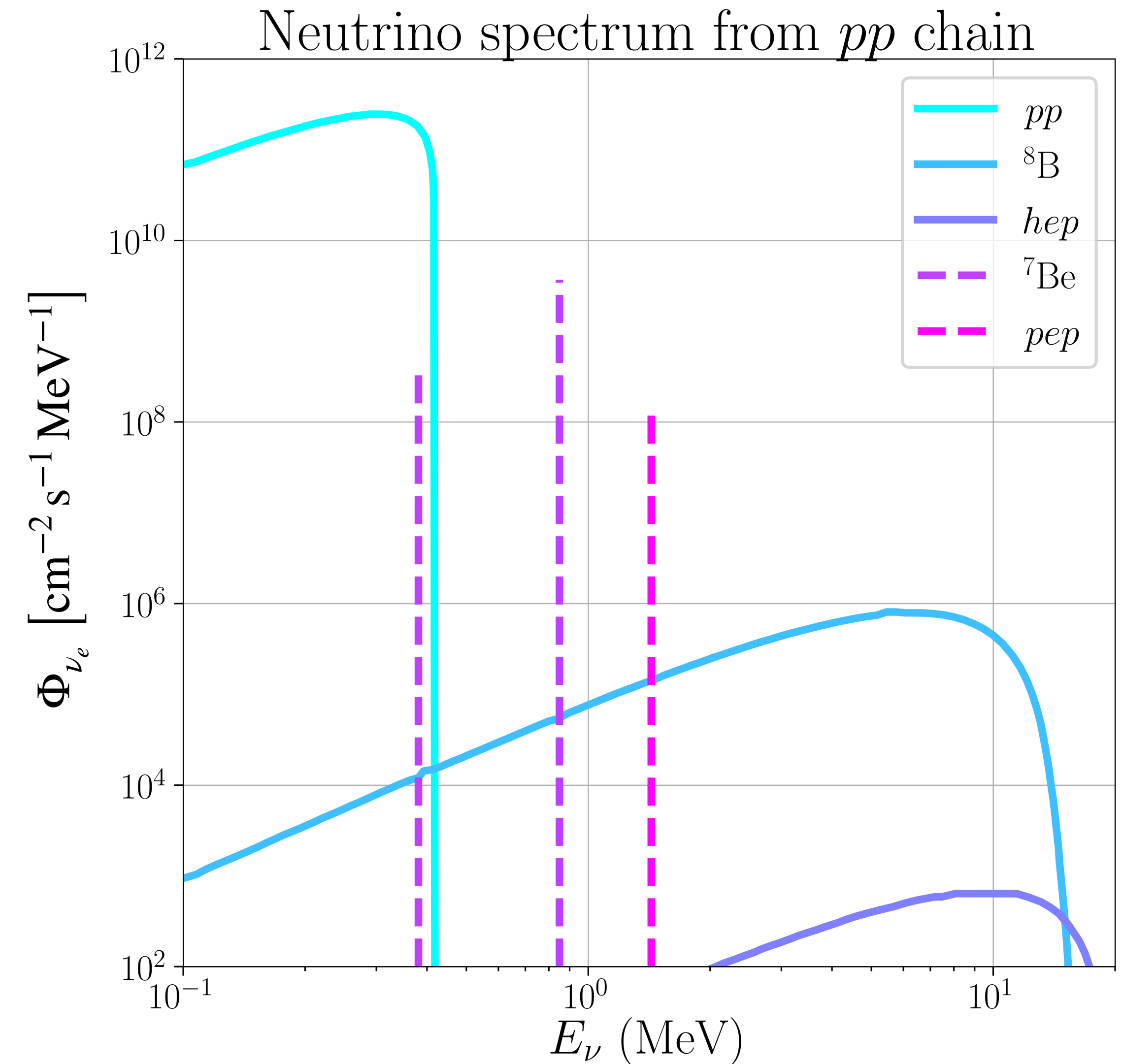
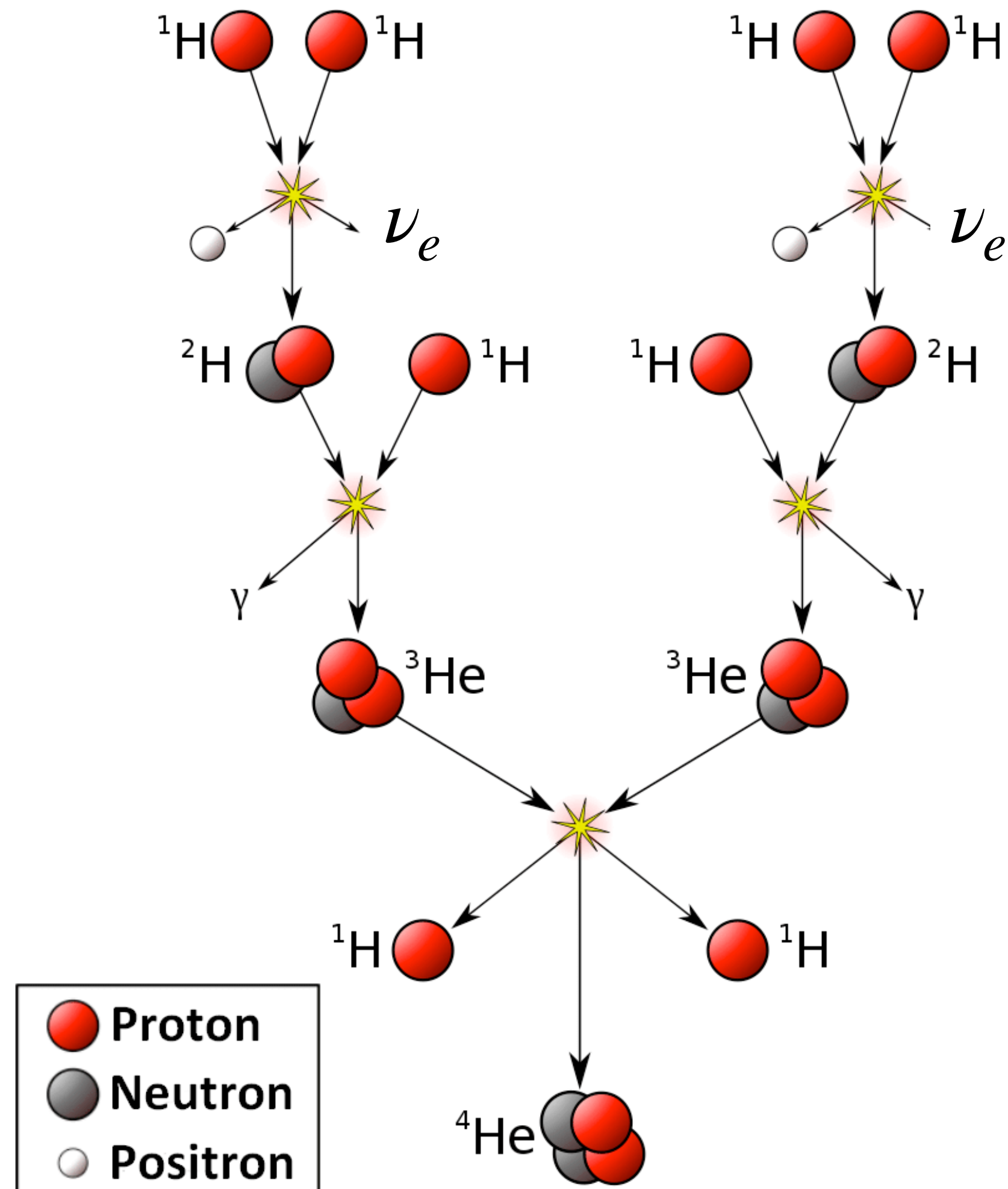

# Staring into the Sun

- Homestake experiment looked for solar  $\nu_e$  via  $^{37}\text{Cl} + \nu_e \rightarrow ^{37}\text{Ar} + e^-$
- First observation of solar neutrinos !

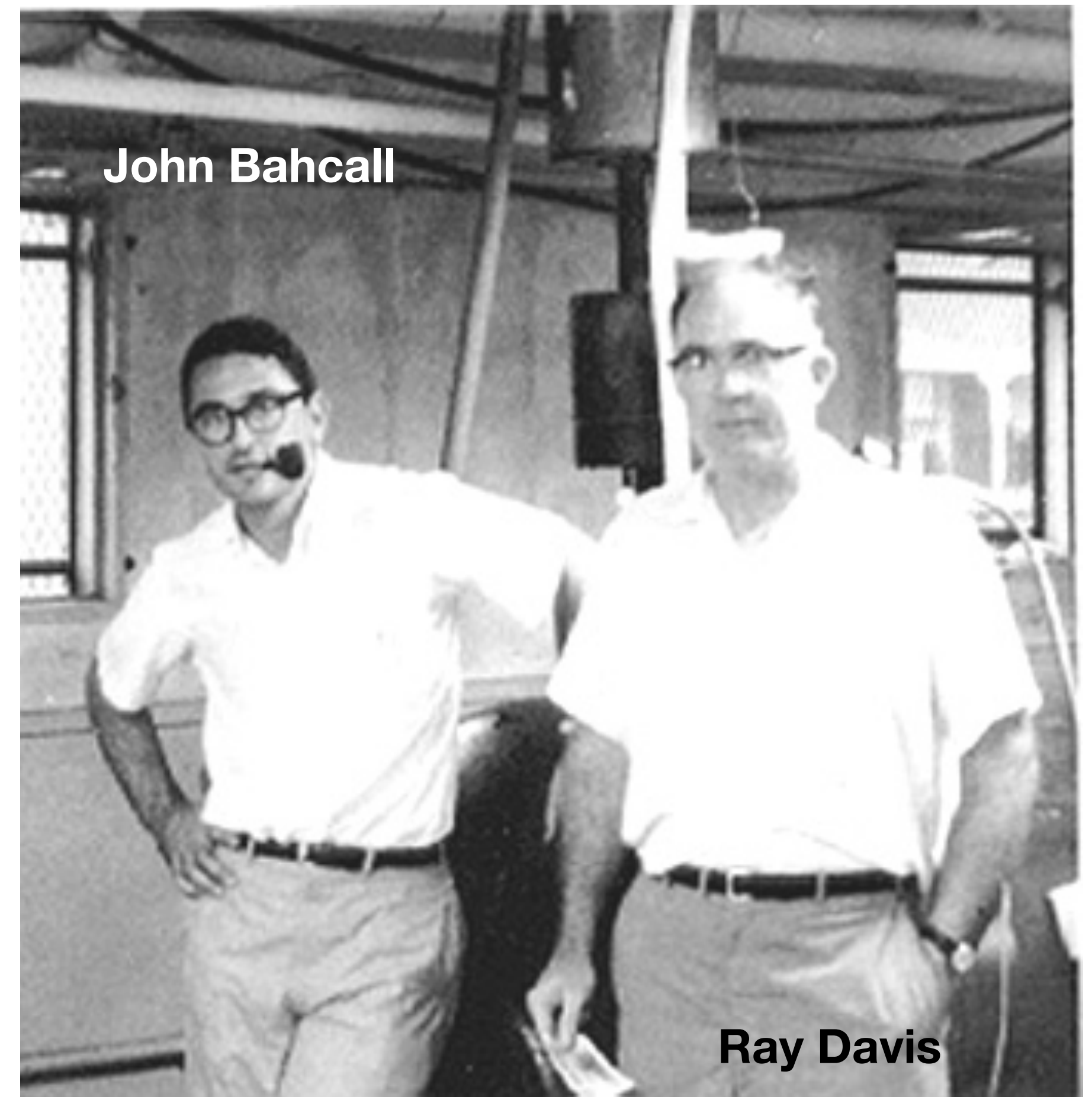
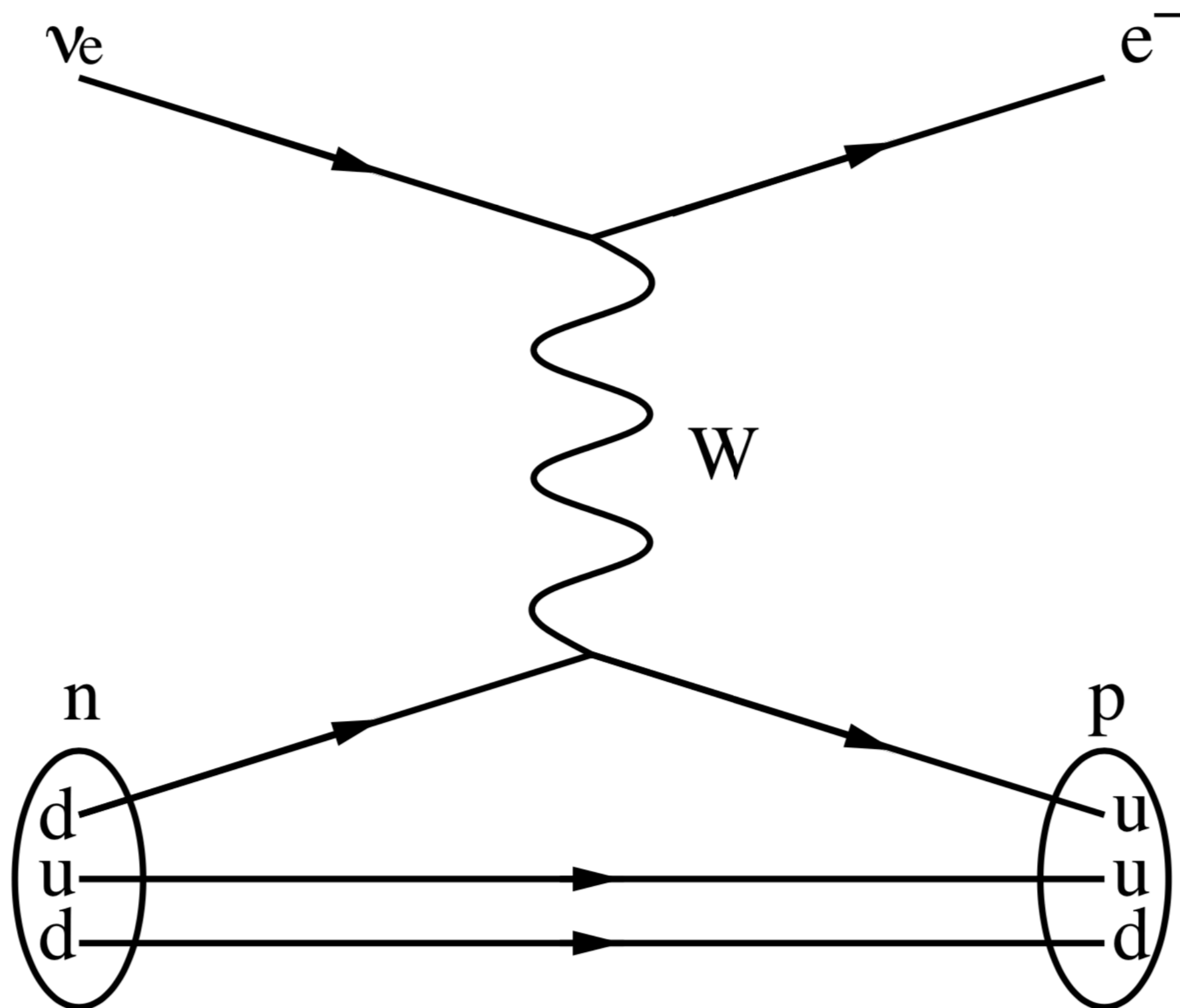

# Staring into the Sun

- Homestake experiment looked for solar  $\nu_e$  via  $^{37}\text{Cl} + \nu_e \rightarrow ^{37}\text{Ar} + e^-$
- First observation of solar neutrinos !

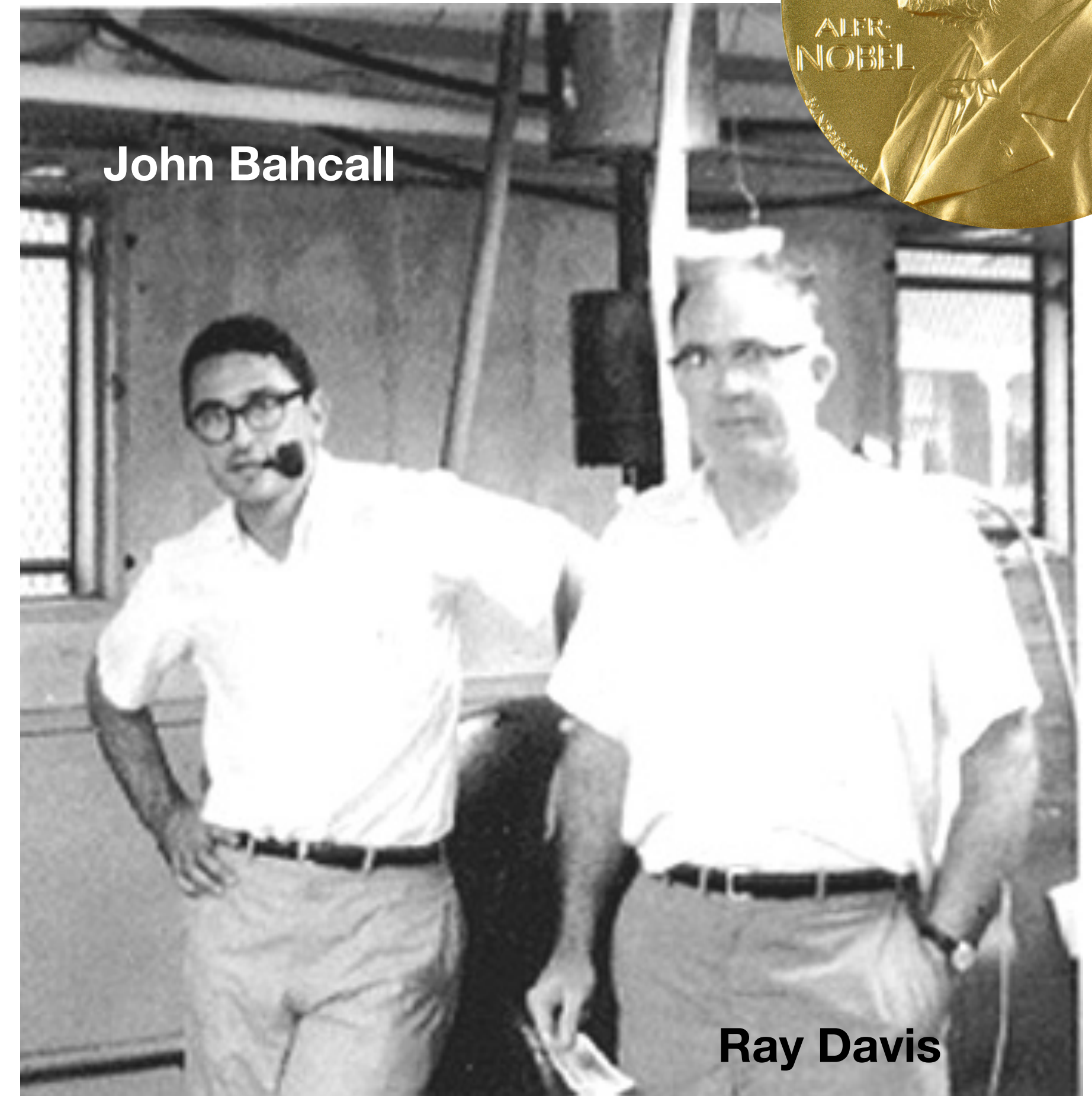
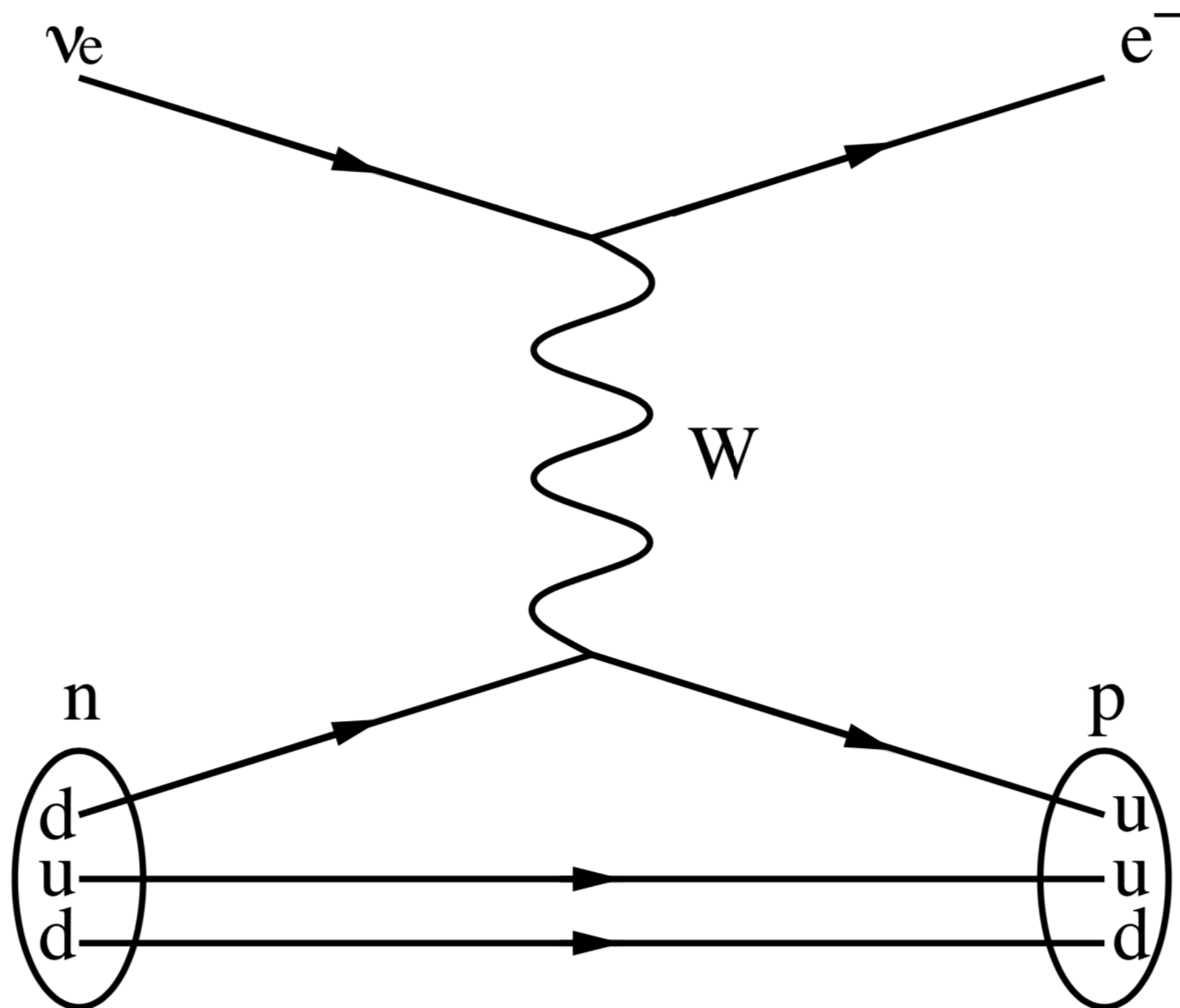

# The Solar Neutrino Problem

- Flux measured by Homestake was in bad agreement with SSM prediction
- Many experiments continued to prod at this discrepancy, while theory is honed
- Discrepancy persisted

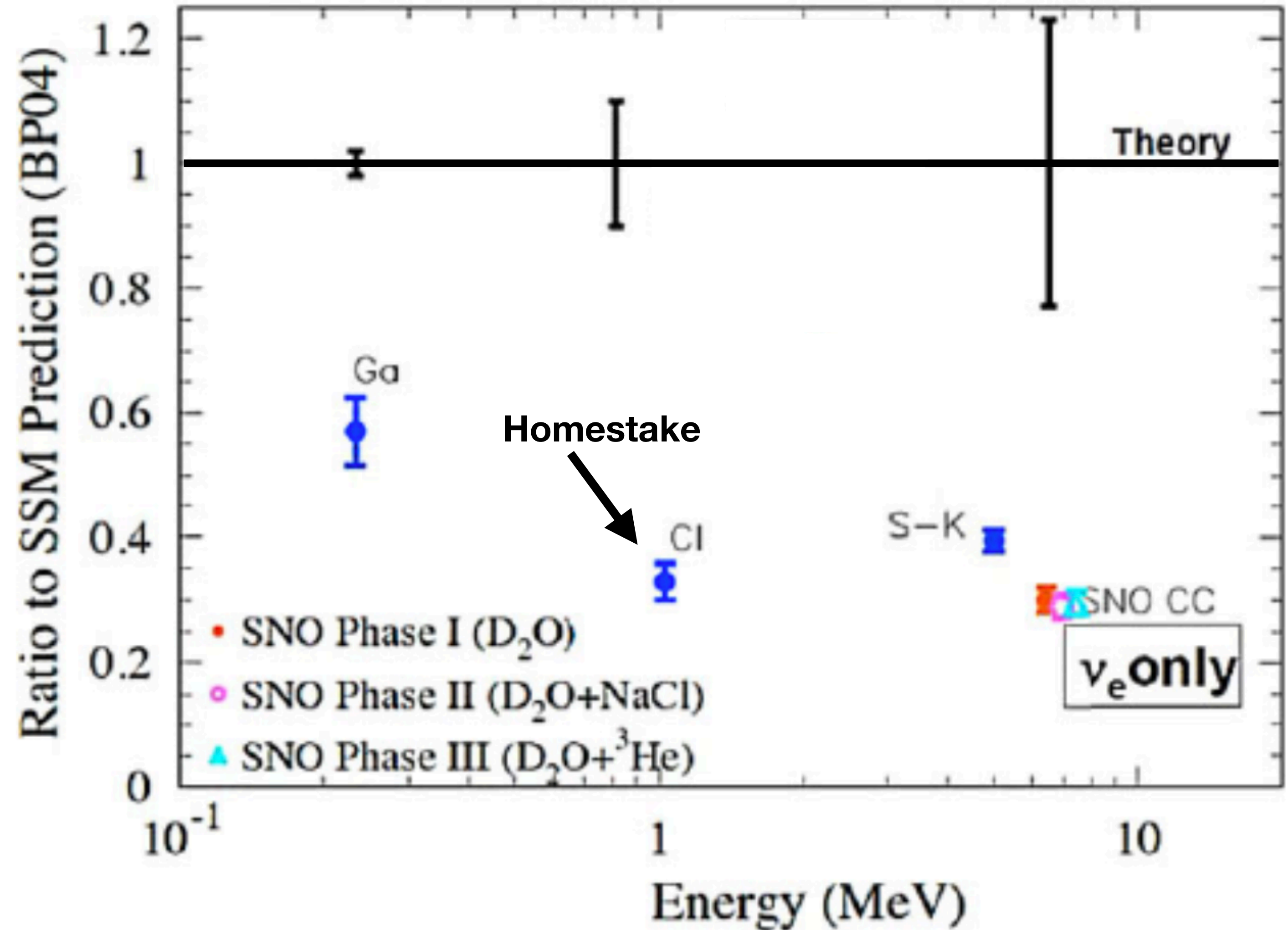

A. McDonald. doi:10.1002/201600031

# Looking at New Flavors

- Sudbury Neutrino Observatory used heavy water water ( $D_2O$ ) to measure all-flavor NC processes

$\nu_e$  only

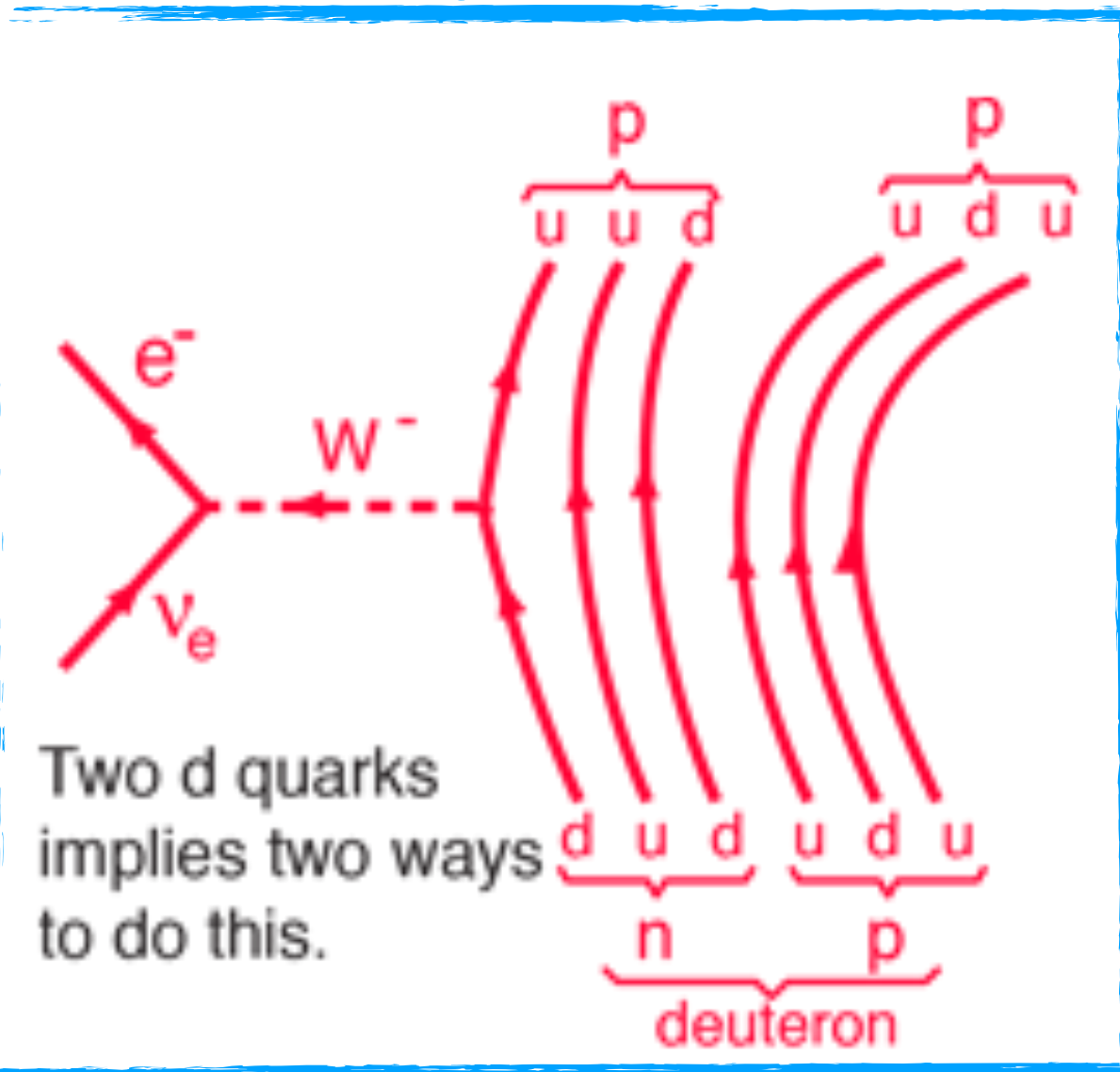

All flavor

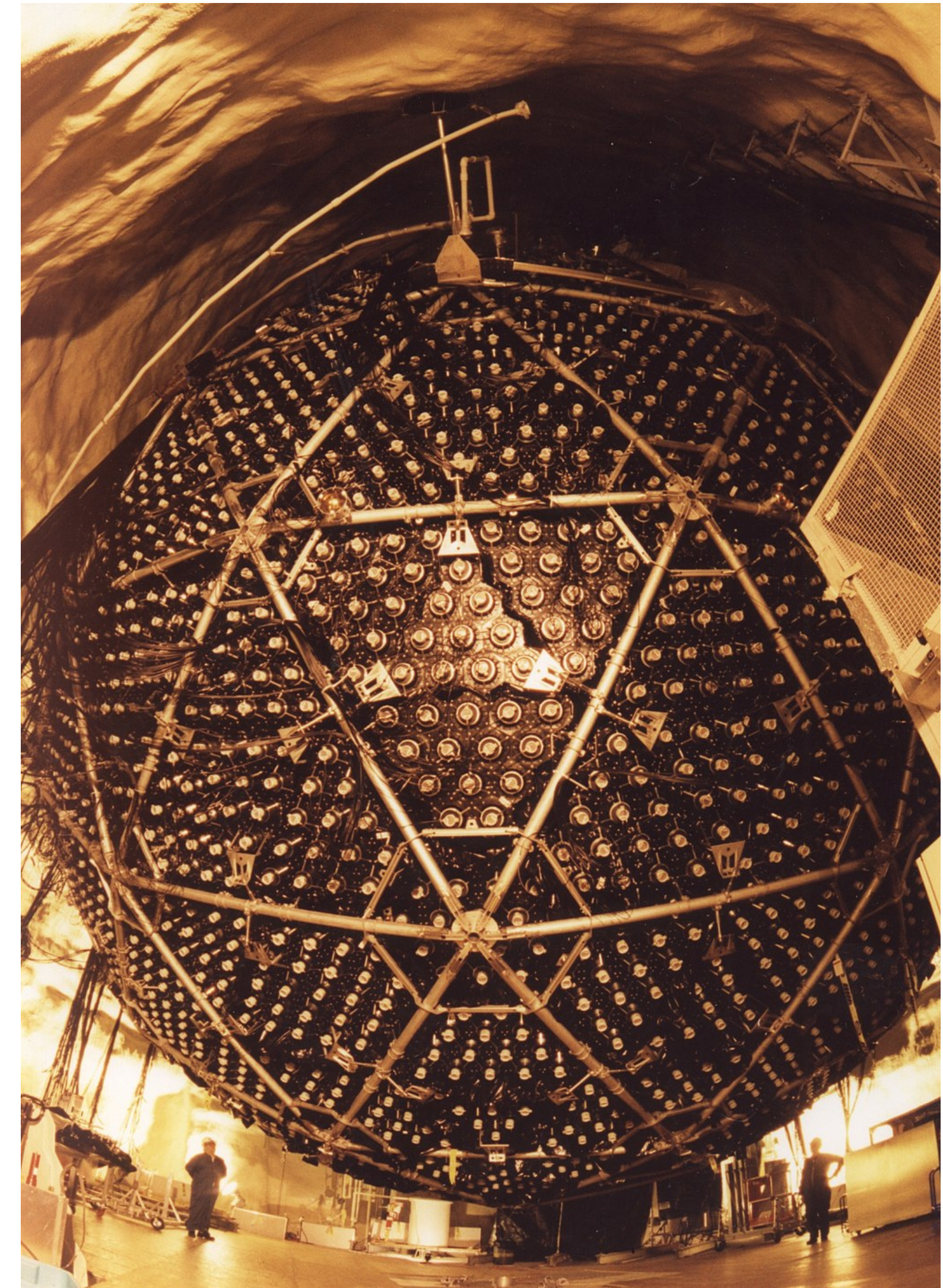
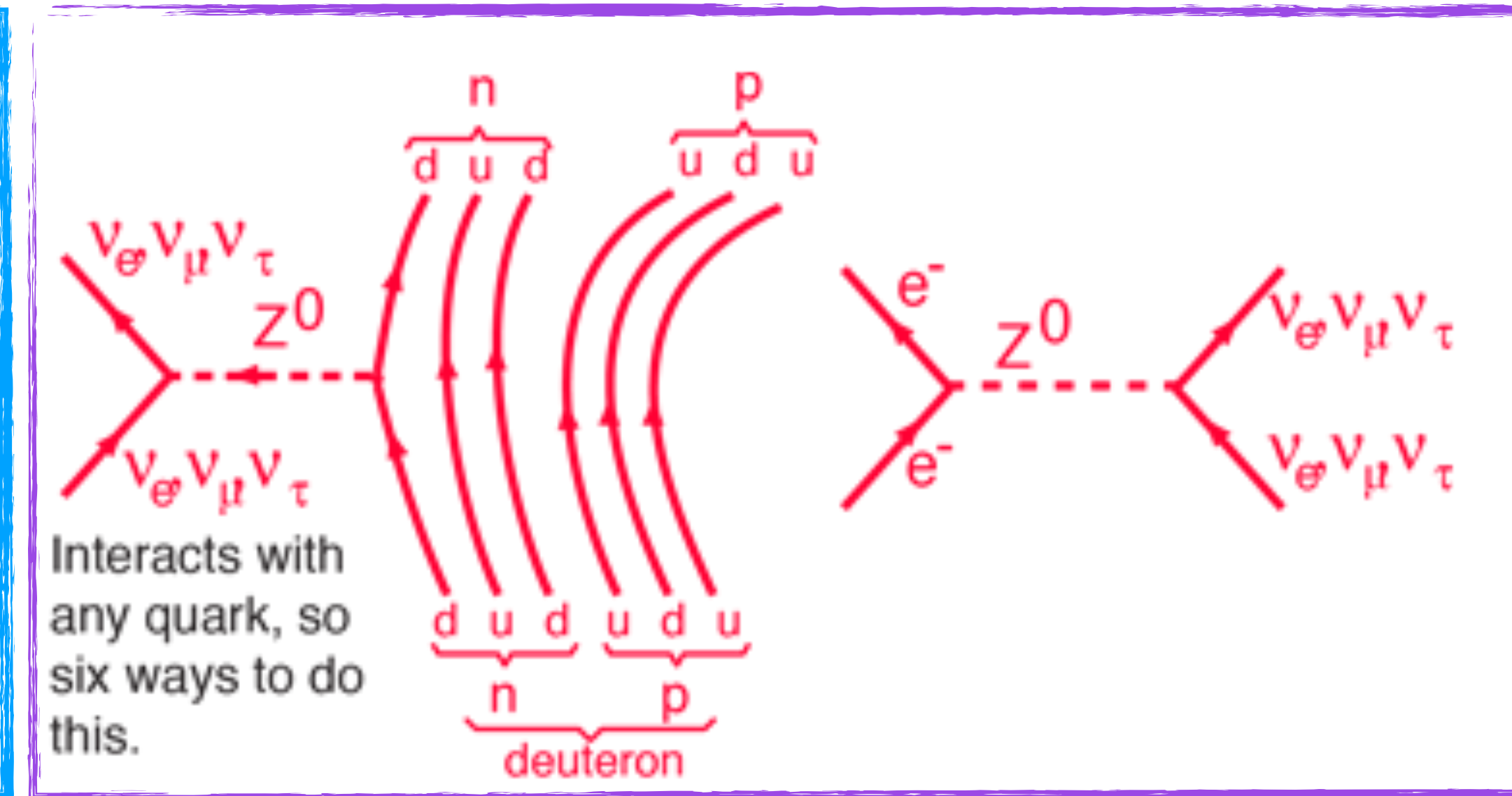

<http://hyperphysics.phy-astr.gsu.edu/hbase/Particles/sno.html>

# Looking at New Flavors

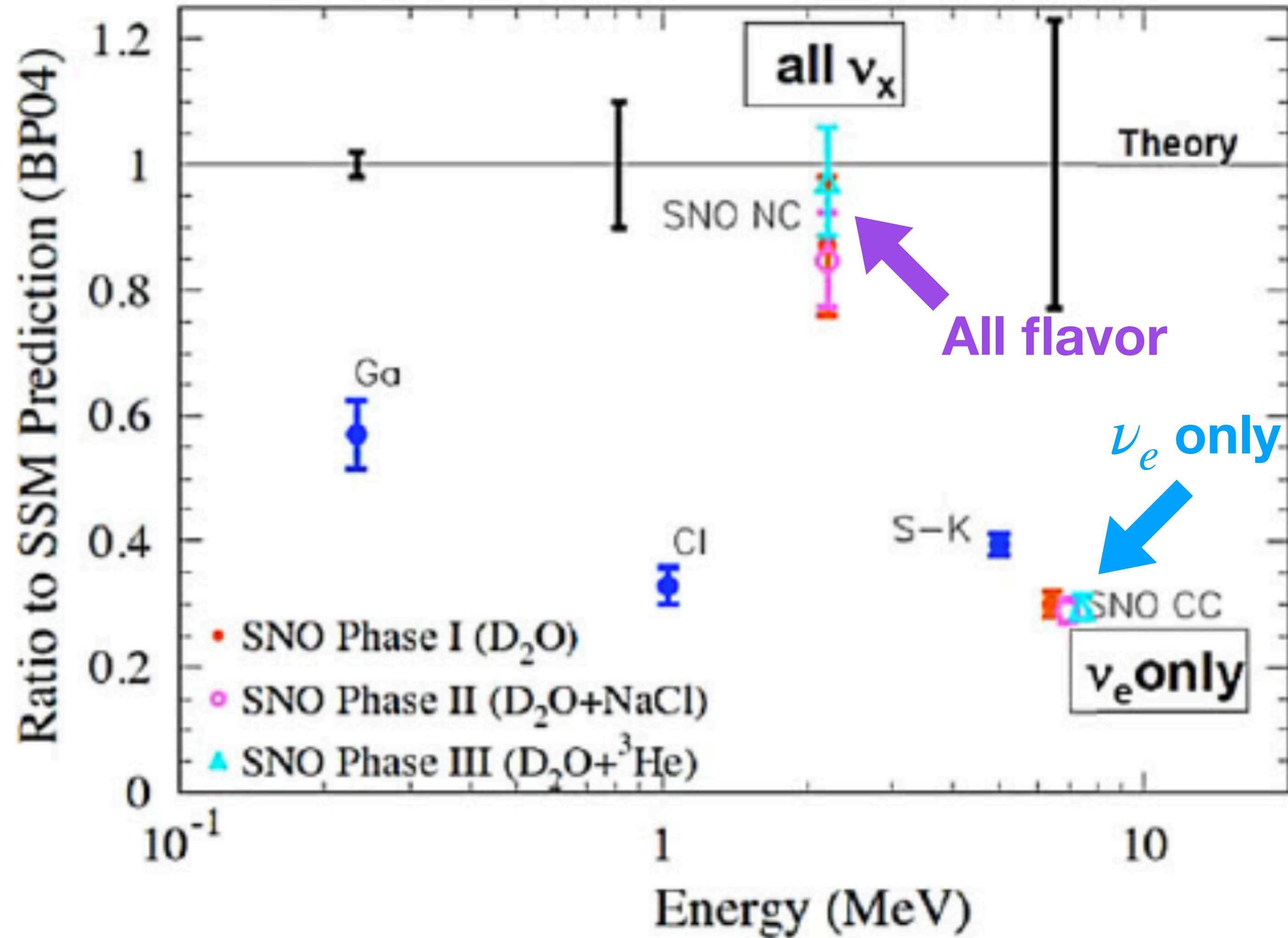

- Discrepancy observed in electron-only measurement
- All flavor measurement in agreement with theoretical predictions

# Looking at New Flavors

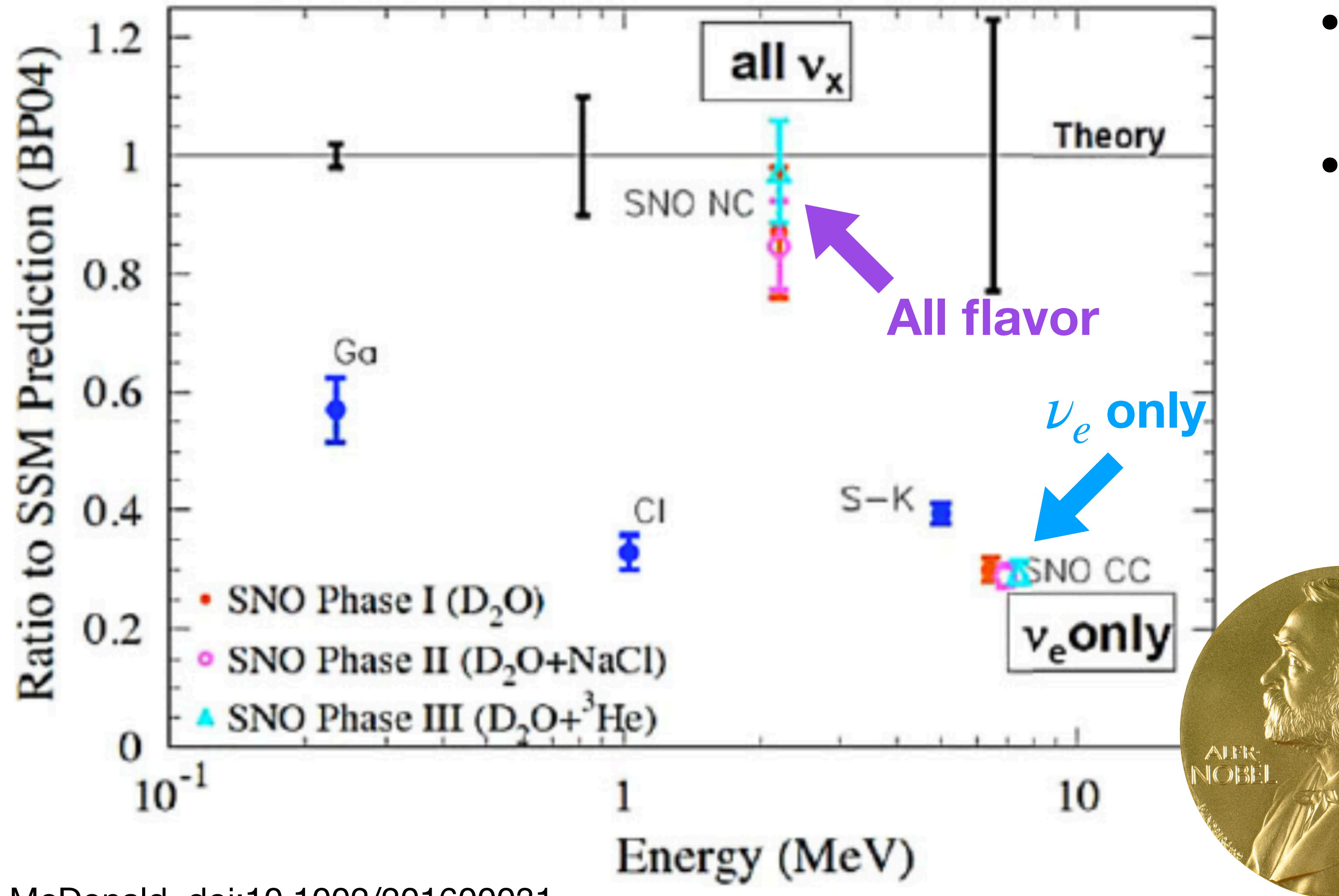

- Discrepancy observed in electron-only measurement
- All flavor measurement in agreement with theoretical predictions

# Looking at New Sources

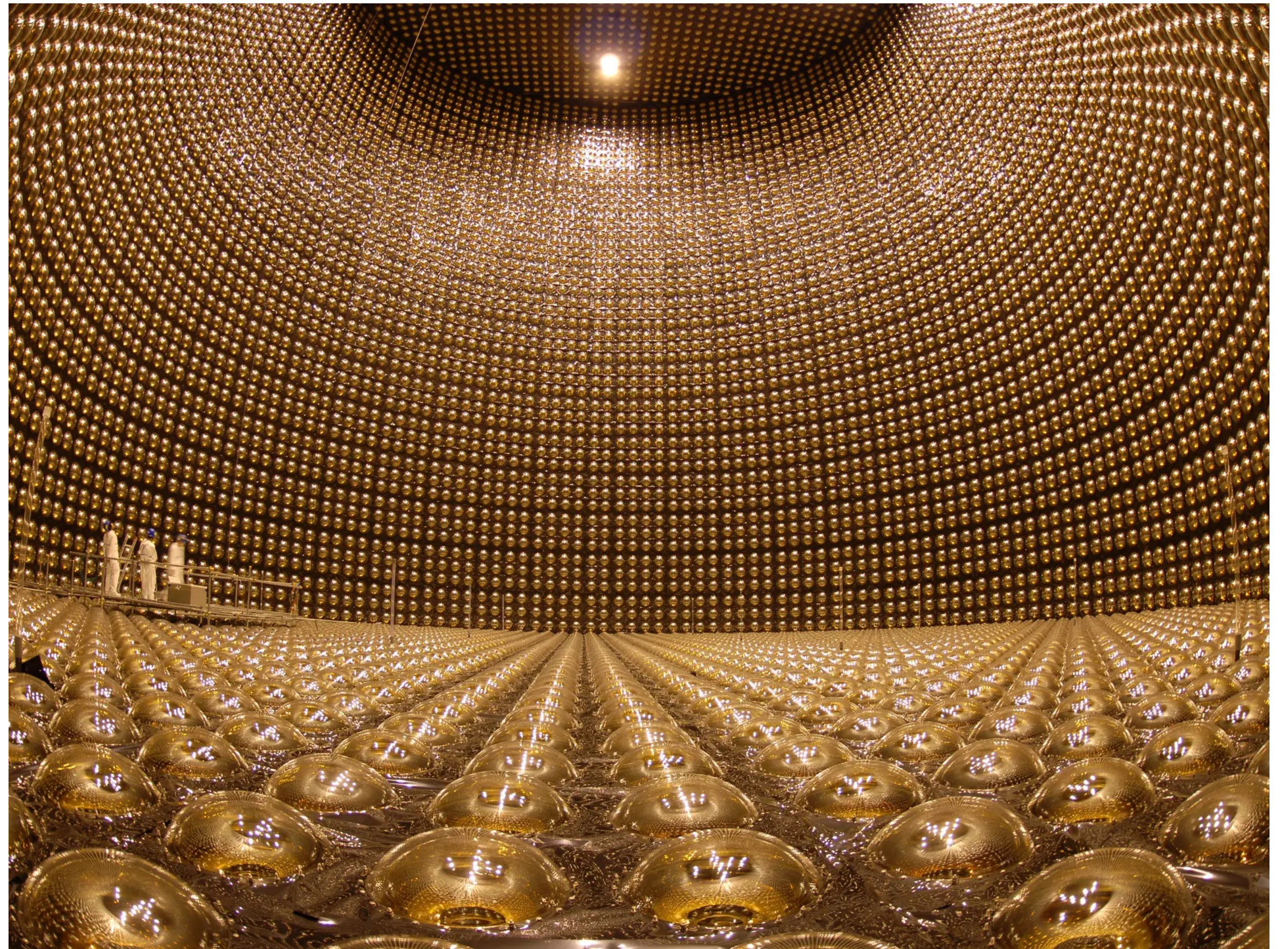
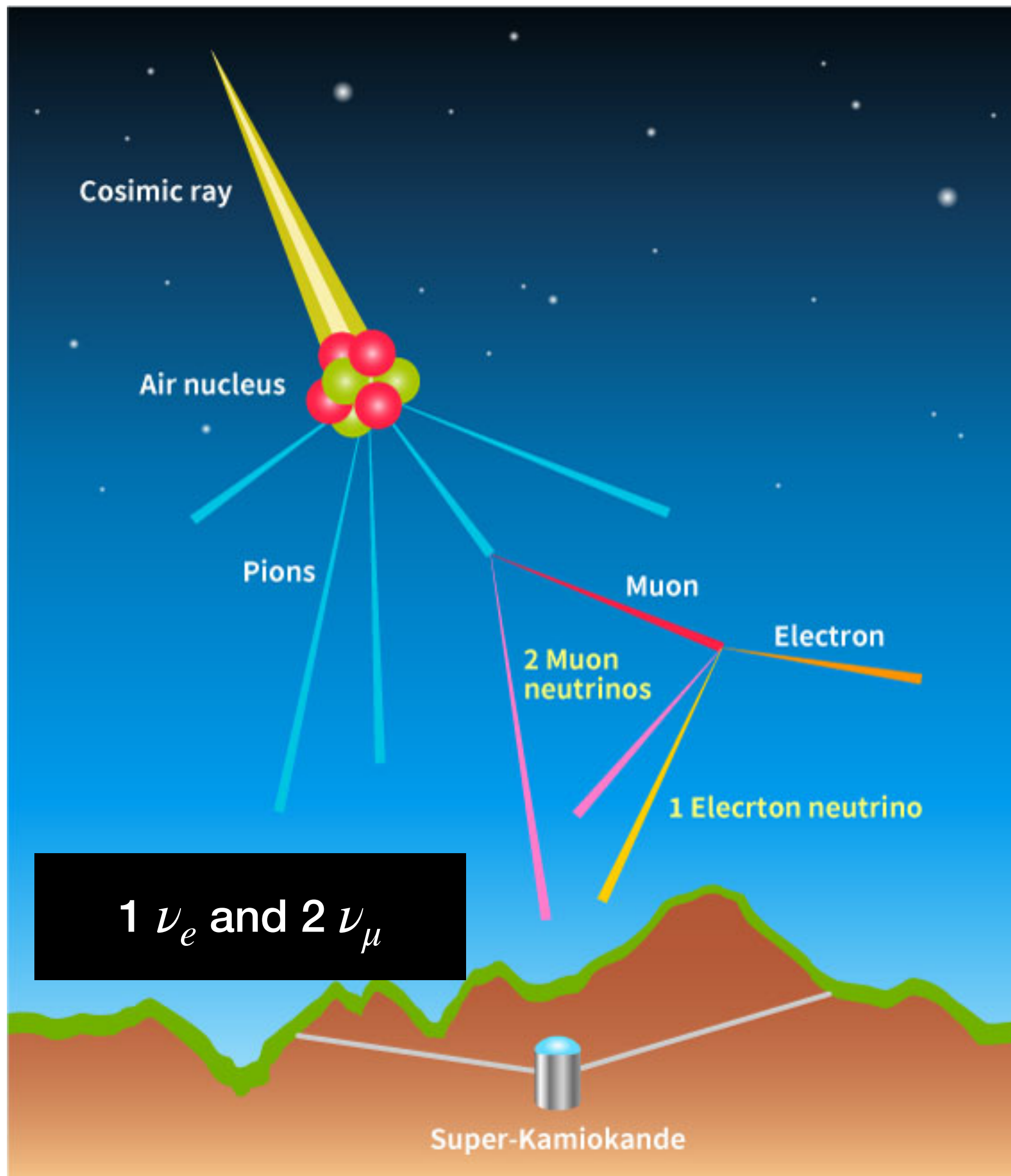

# Looking at New Sources

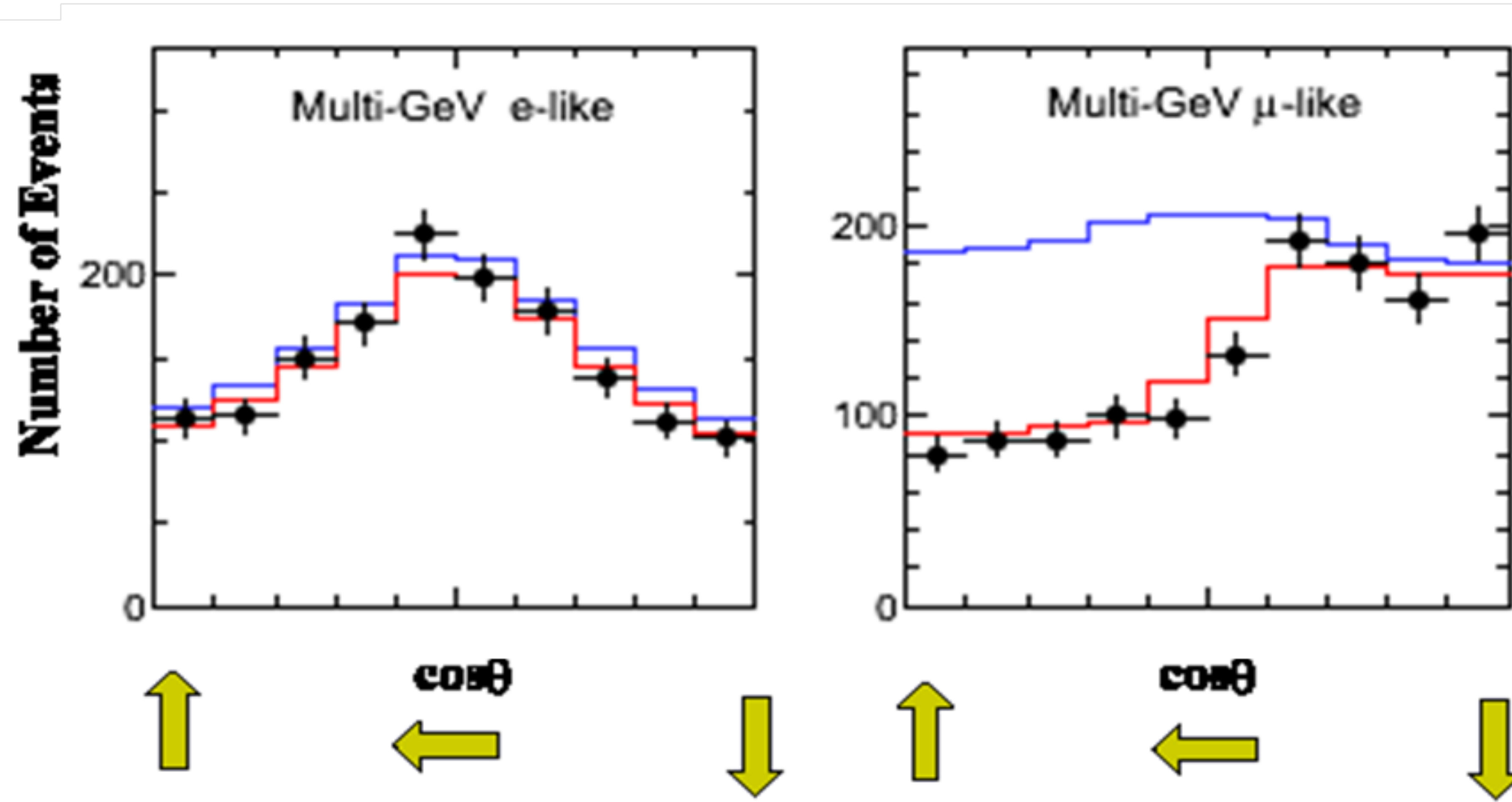

- SuperK saw a deficit of  $\nu_{\mu}$  coming through the Earth
- This confirmed neutrinos neutrino in-flight flavor change

# Looking at New Sources

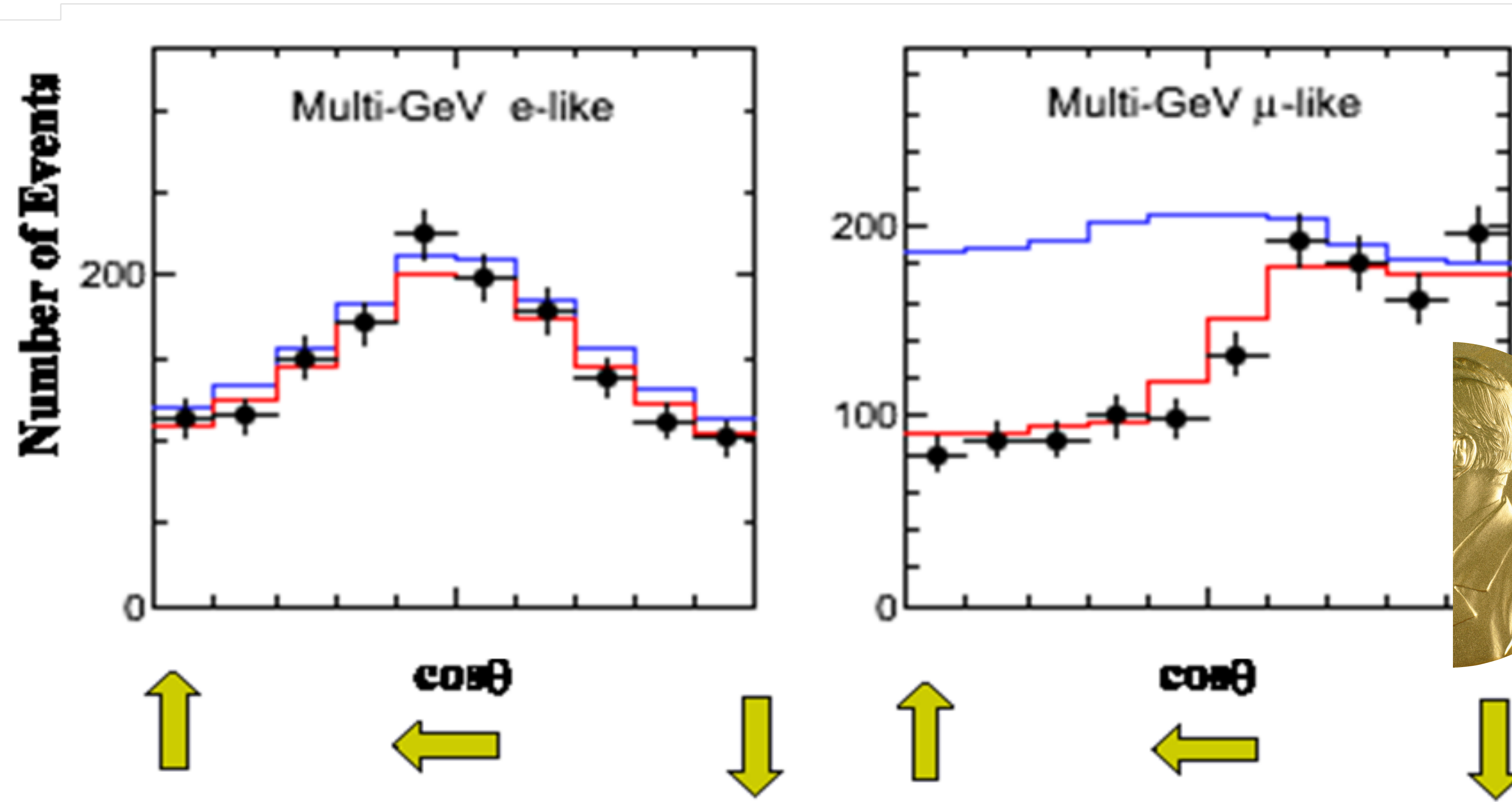

- SuperK saw a deficit of  $\nu_{\mu}$  coming through the Earth
- This confirmed neutrinos neutrino in-flight flavor change

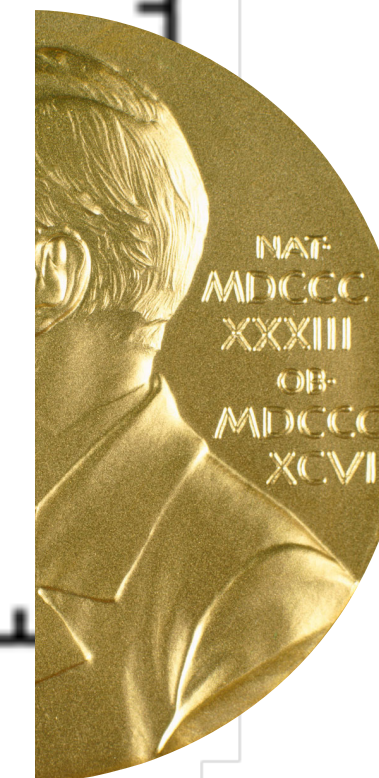



Understanding the *flavor*, *energy*, and *directional* information of non-terrestrial neutrinos have played a pivotal role in shaping our understanding of the Sun, neutrino physics, and the Standard Model more broadly

Understanding the *flavor*, *energy*, and *directional* information of non-terrestrial neutrinos have played a pivotal role in shaping our understanding of the Sun, neutrino physics, and the Standard Model more broadly

**So, where do we go from here ?**

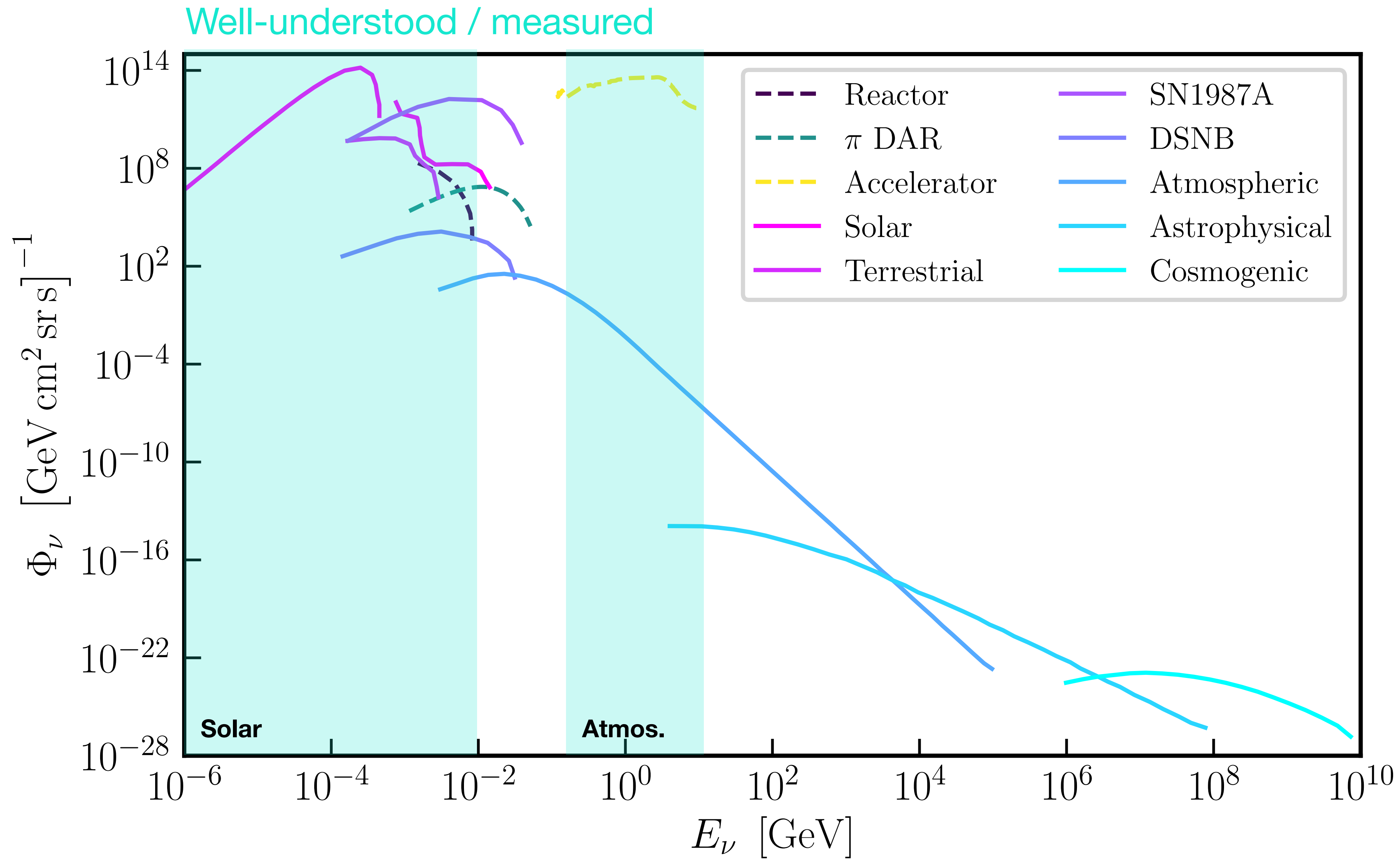

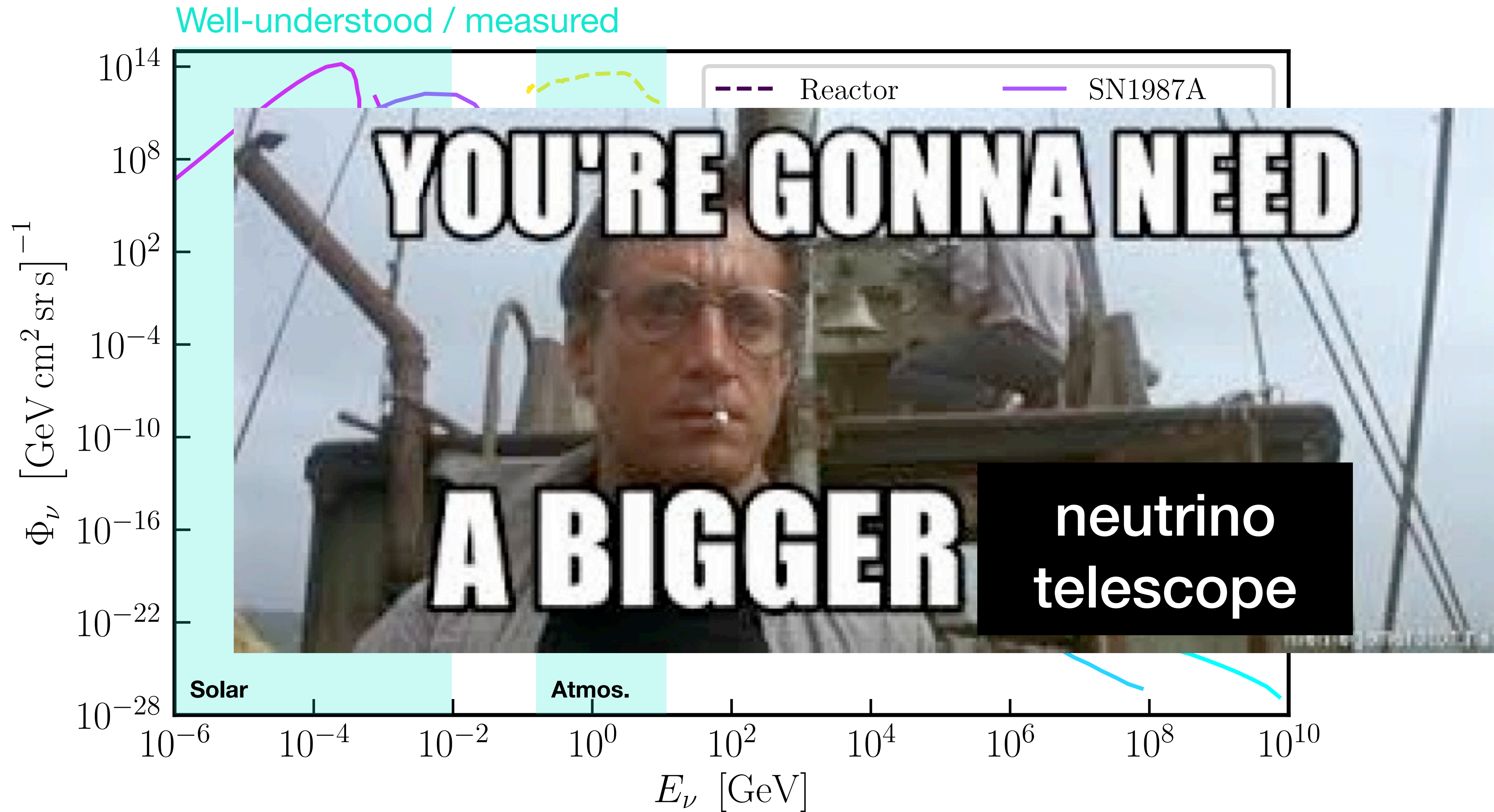

# The IceCube Neutrino Observatory

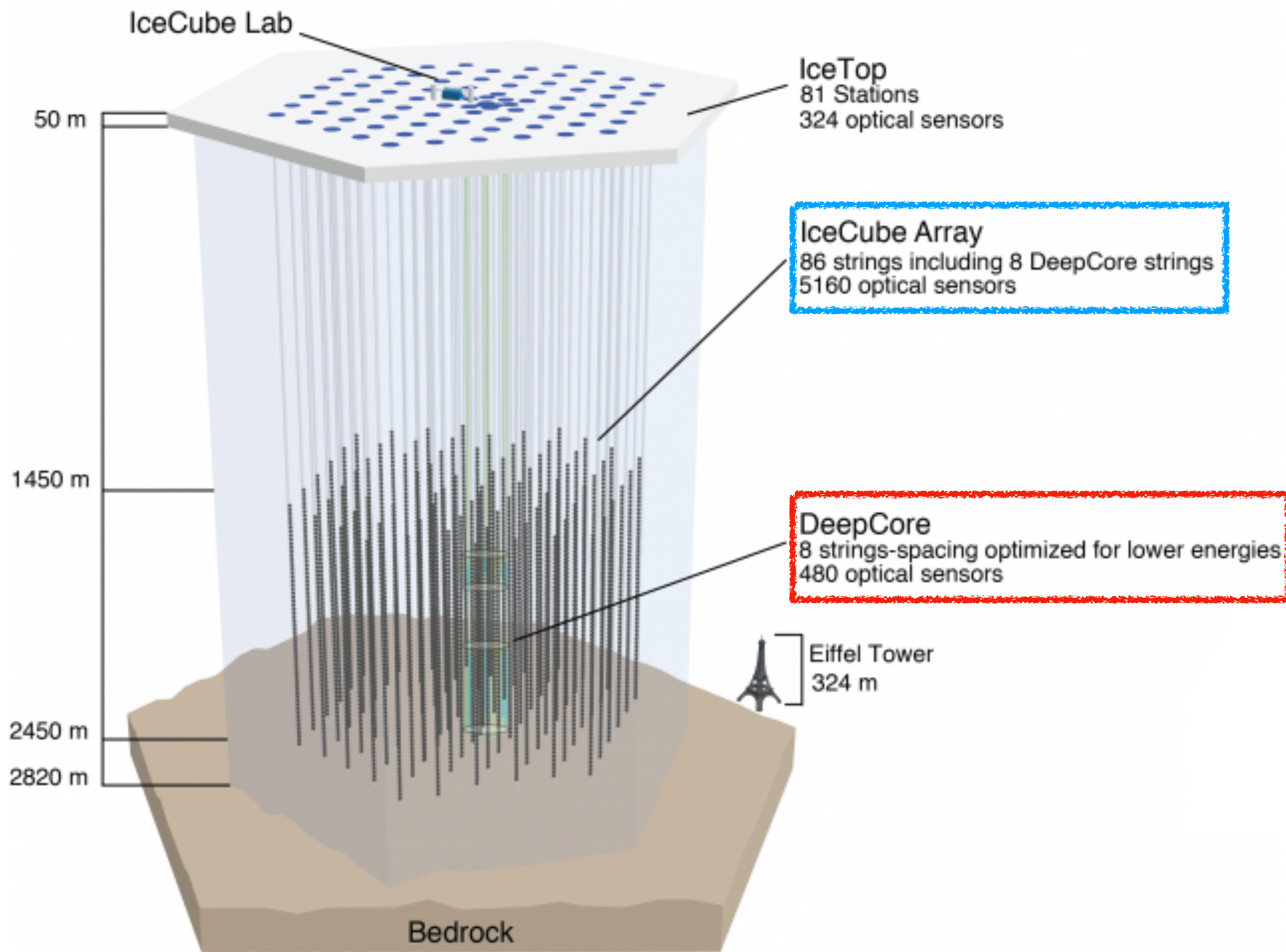

Gigaton scale detector of 5,160 light detecting digital optical modules (DOMs)

IceCube and DeepCore sensitive to high- and low-energy neutrinos

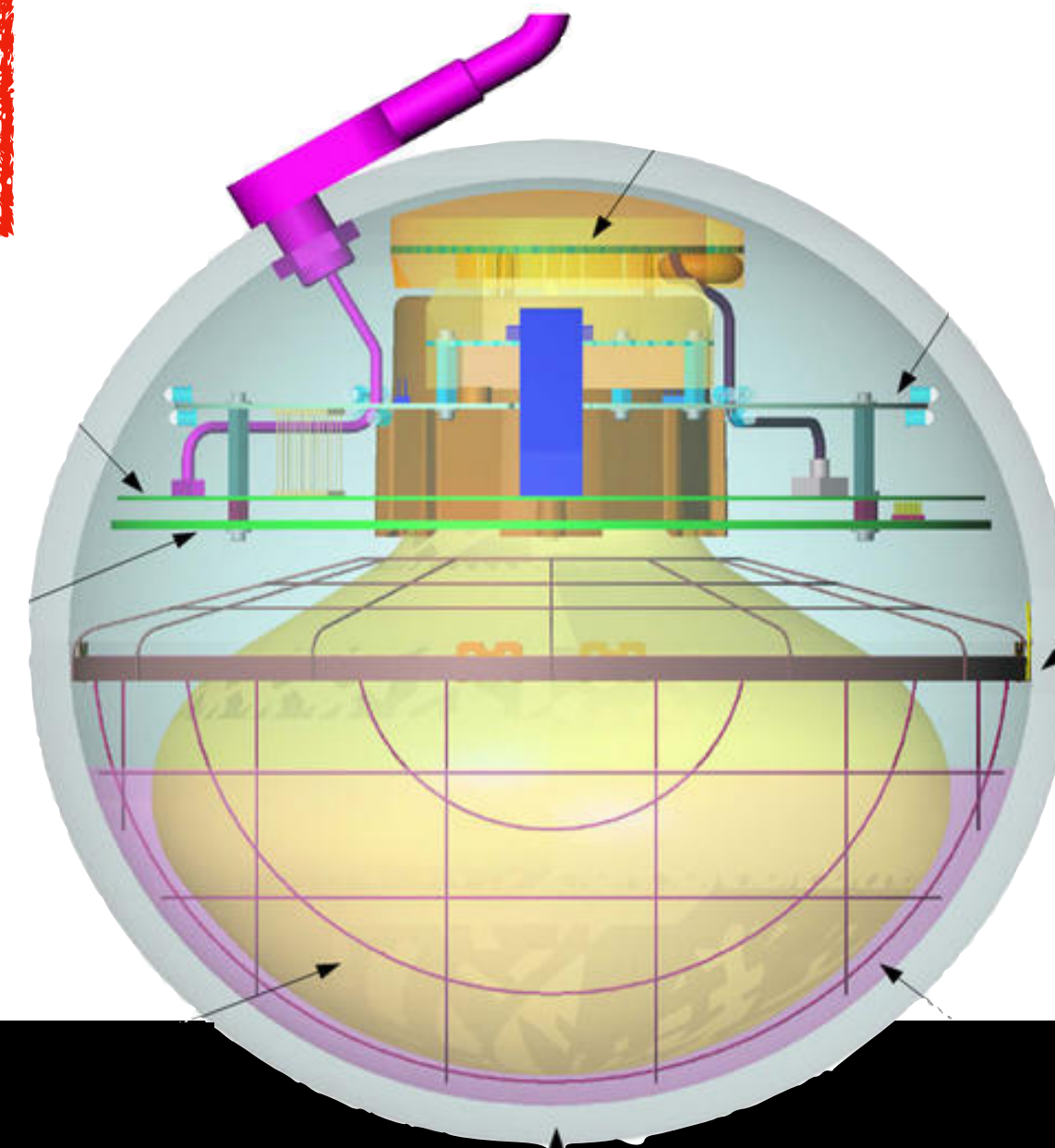

# Unfolding Light and Time

Cascades

$\nu_e$  CC |  $\nu_\alpha$  NC

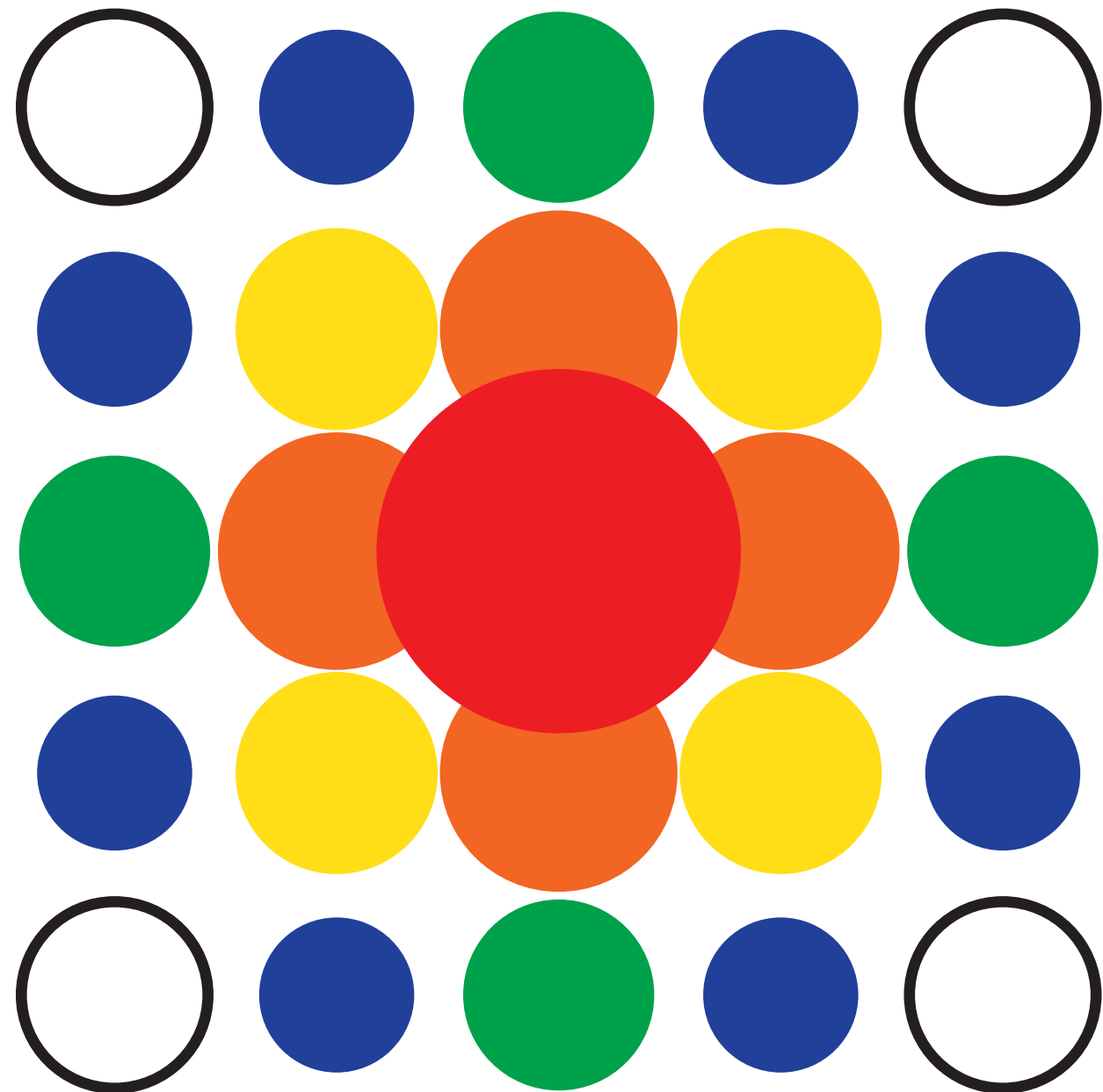

Great energy resolution, but angular reconstruction is challenging

Tracks

$\nu_\mu$  CC

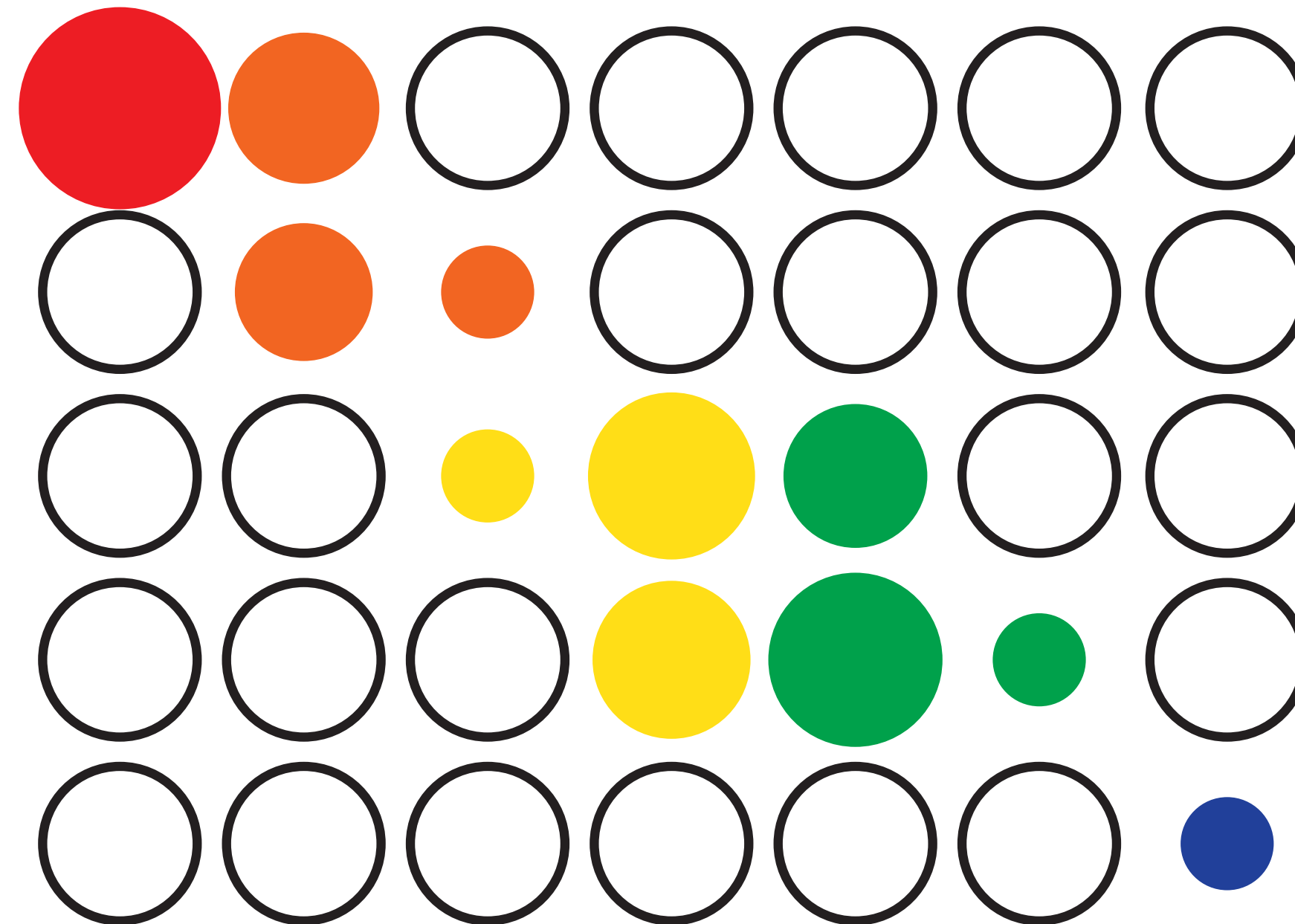

Great directional resolution, but deposited energy not proportional to  $E_\nu$

Double bangs

$\nu_\tau$  CC

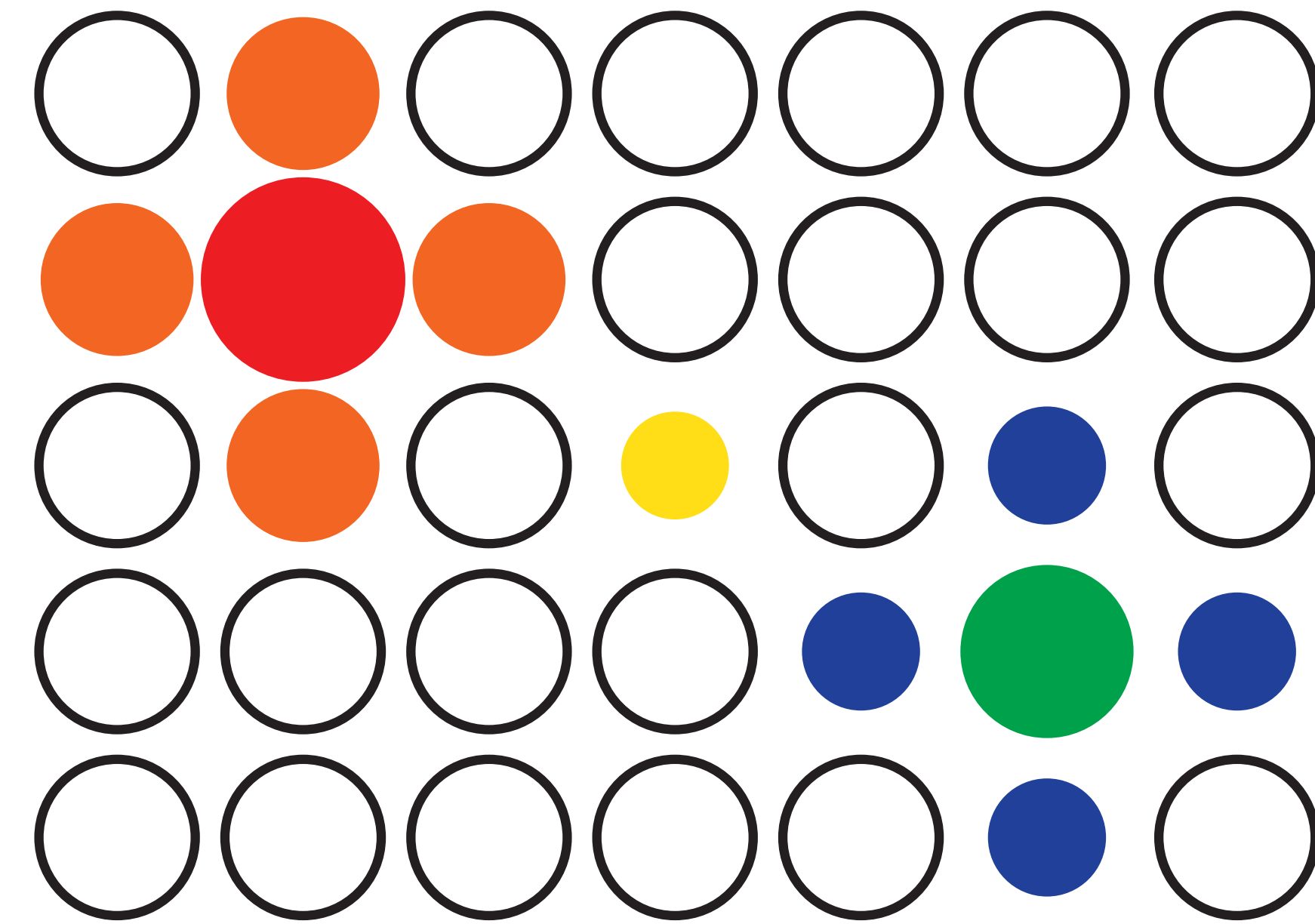

Signature of  $\nu_\tau$  CC events

# What Do we look for

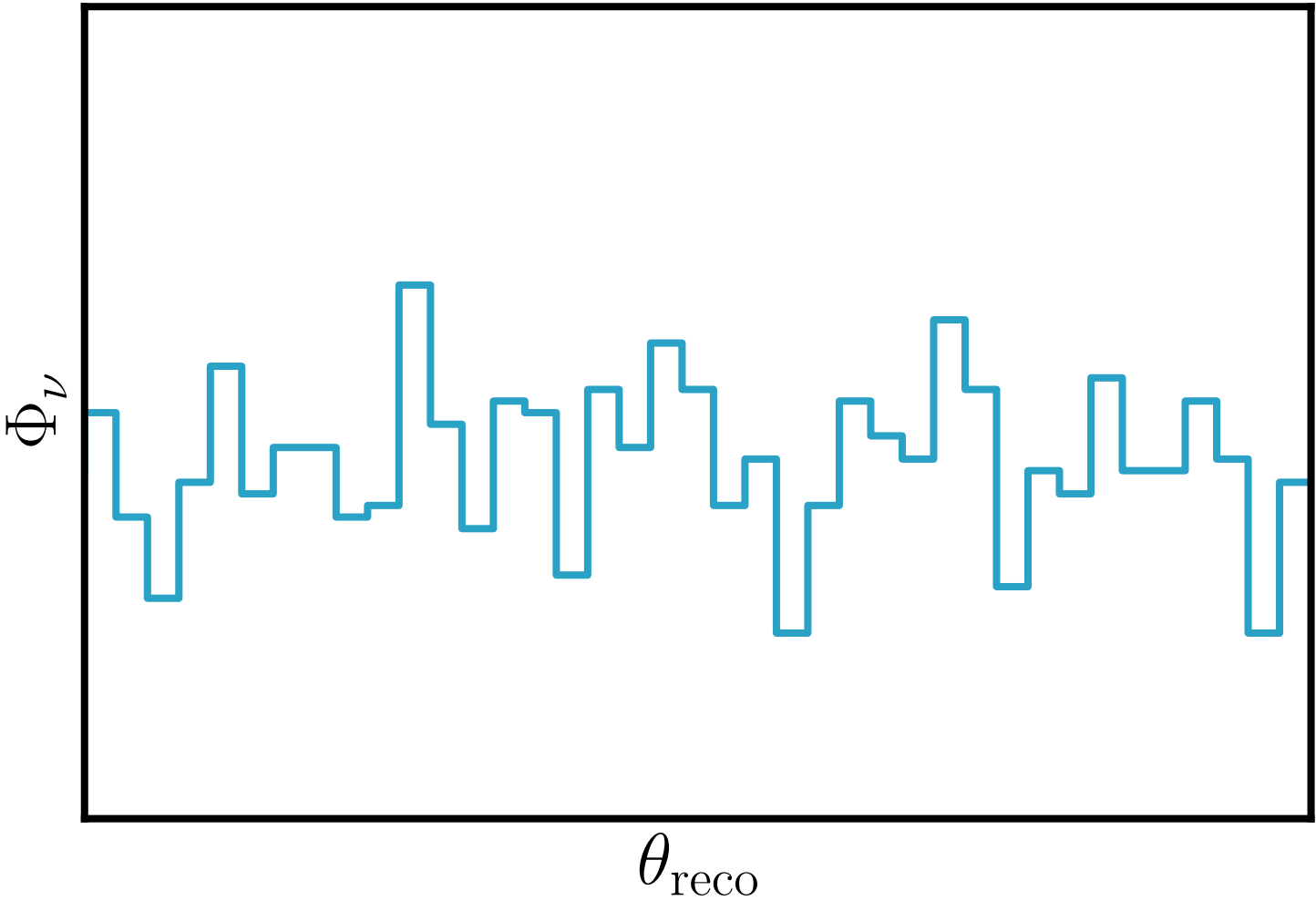
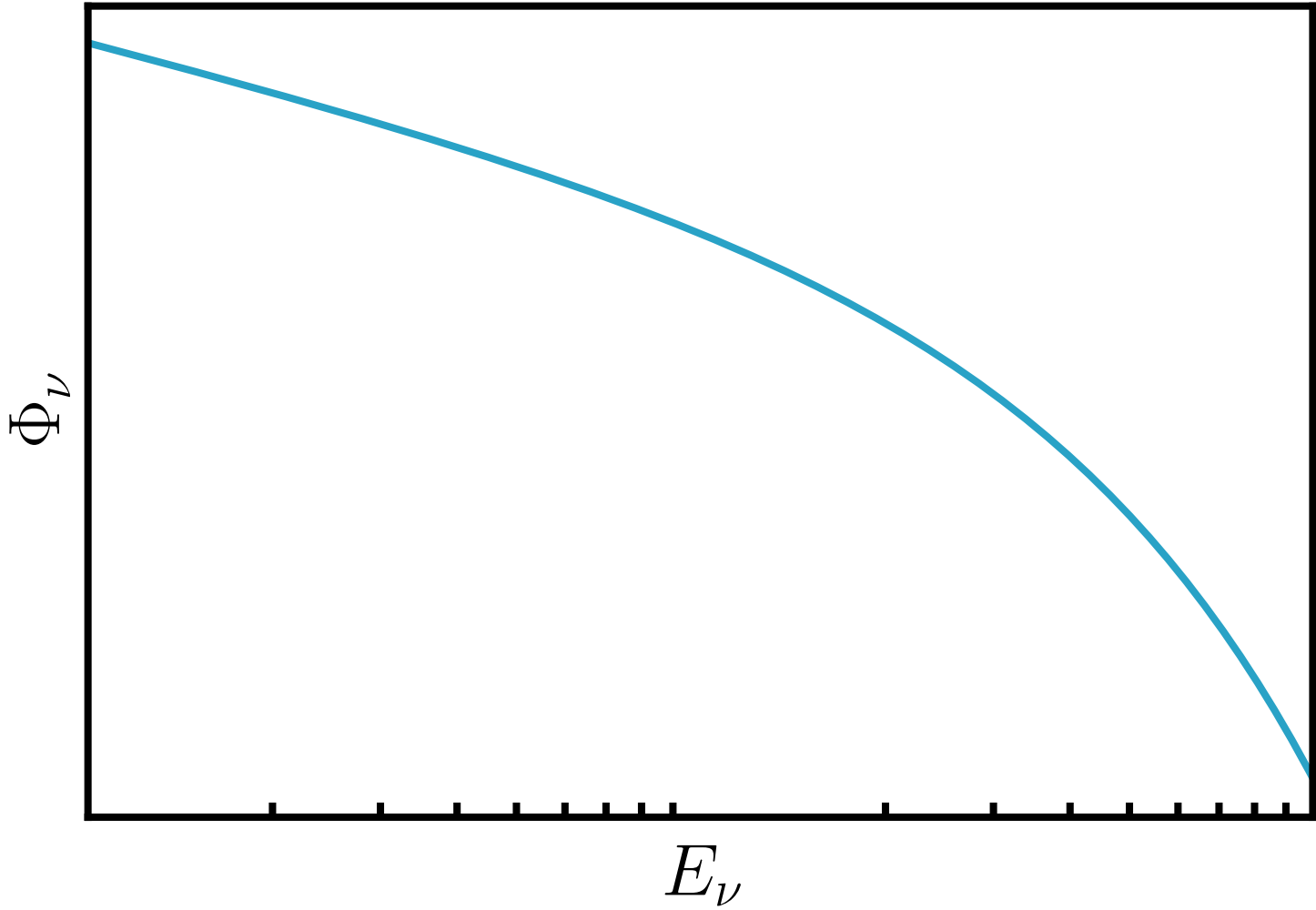
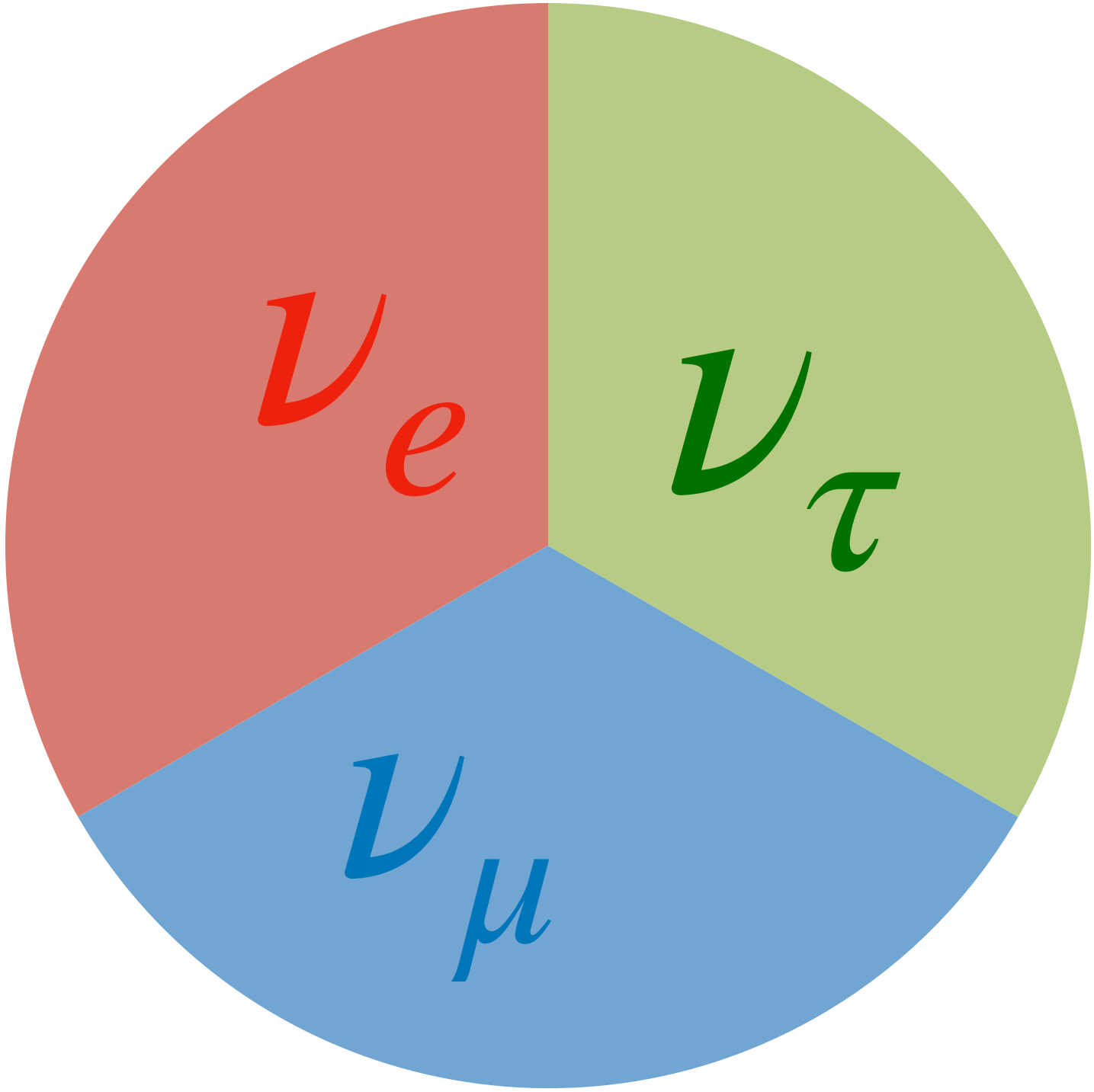

# What Do we look for

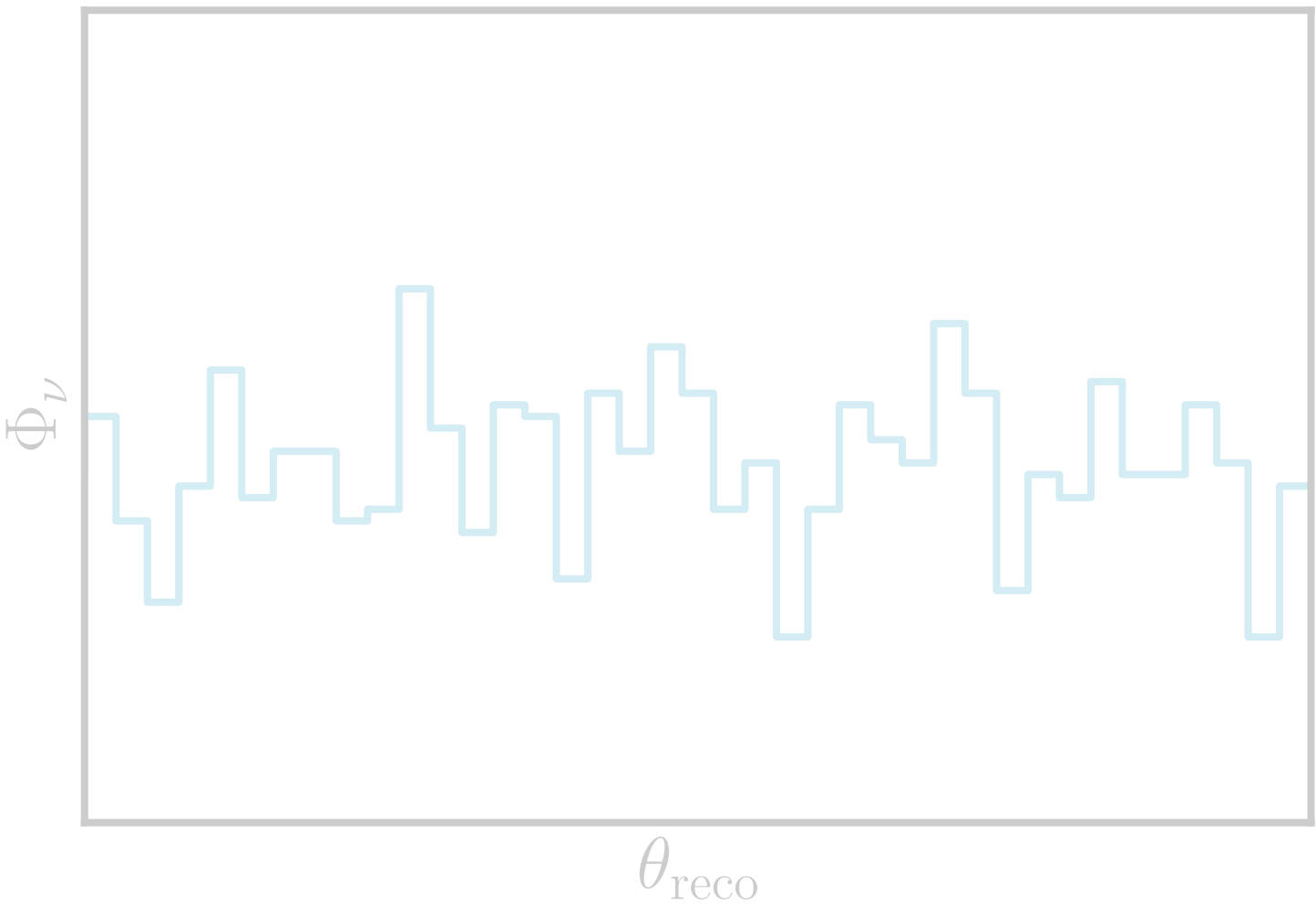
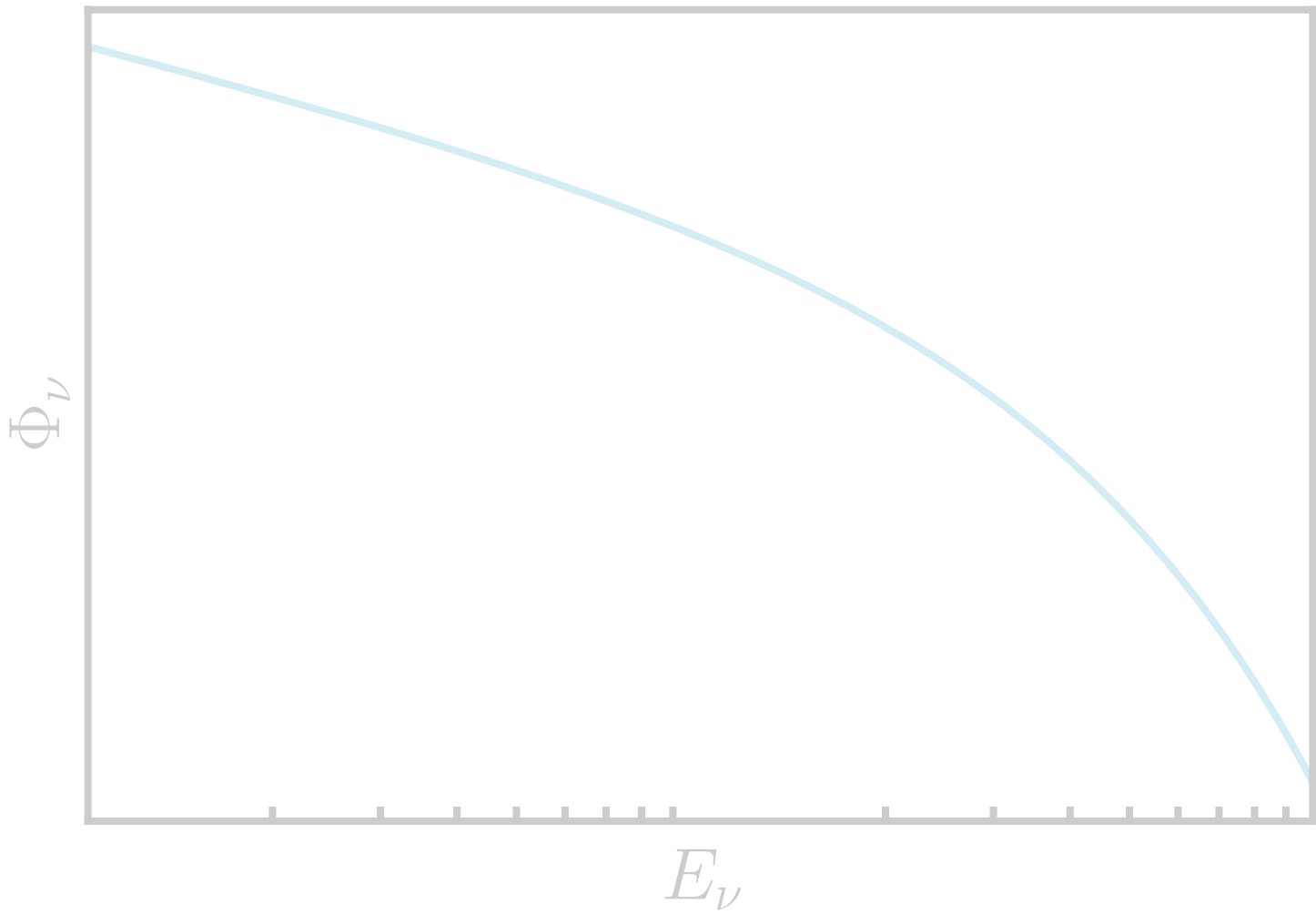
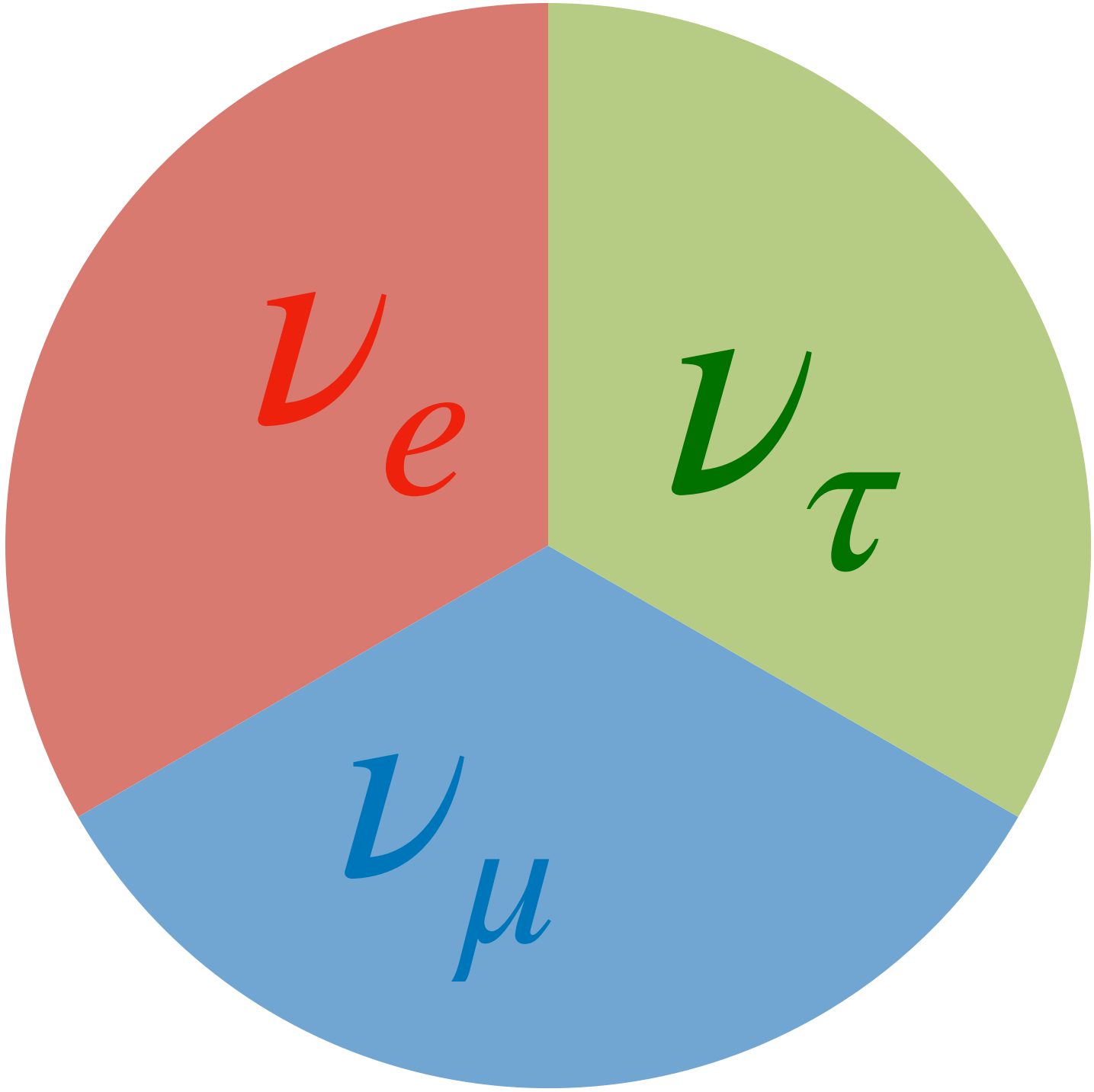

# What Do we look for

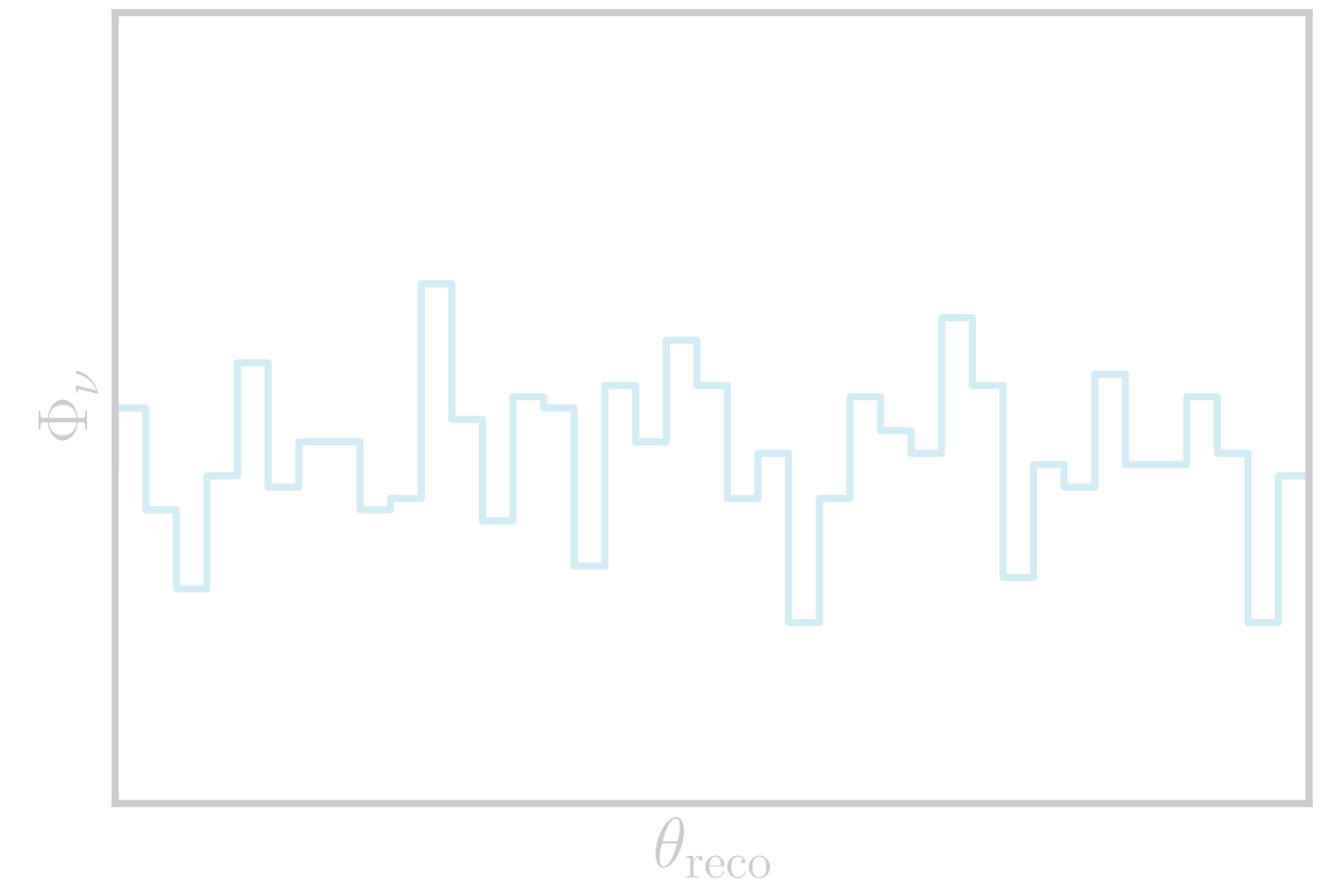
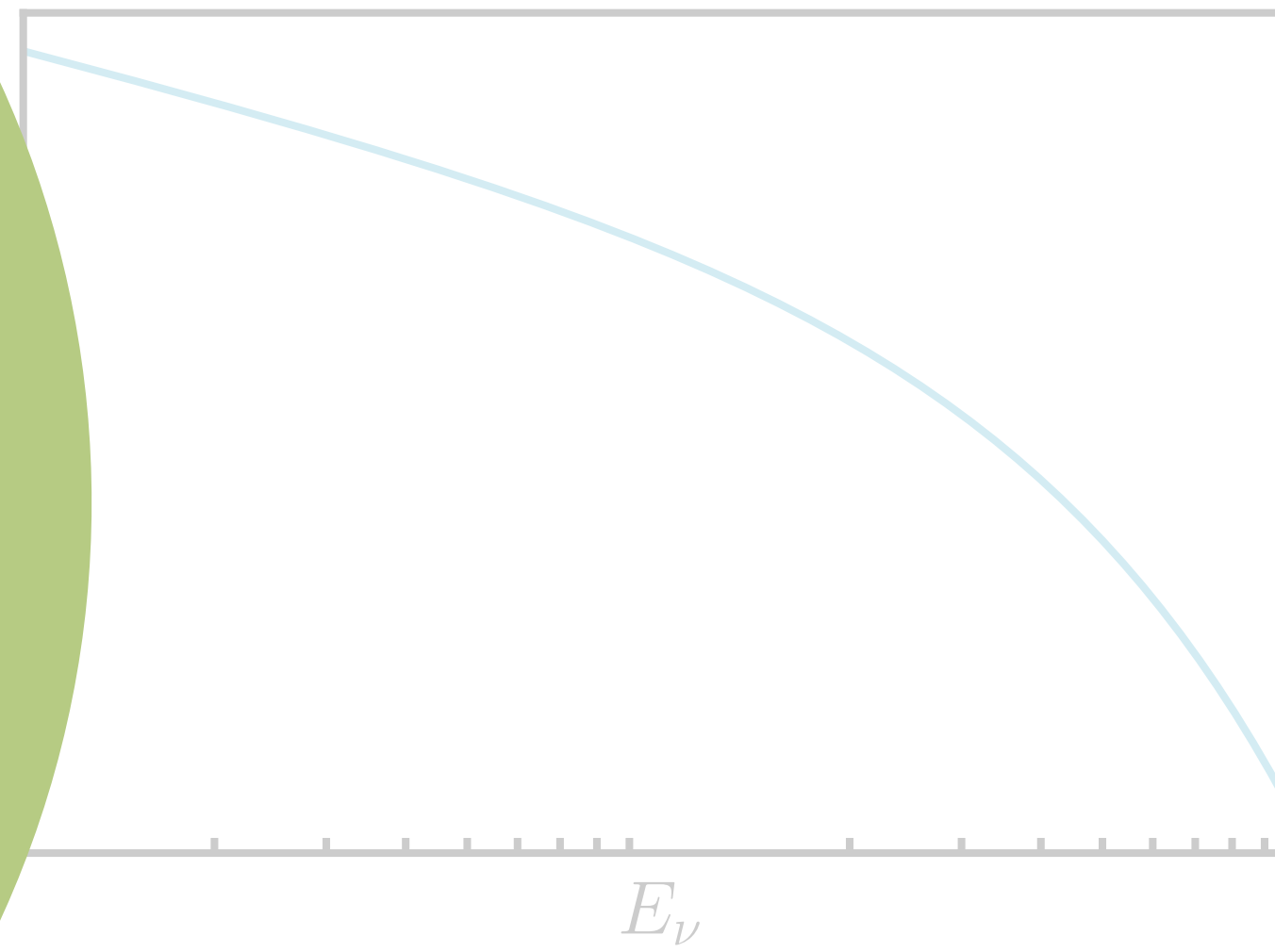
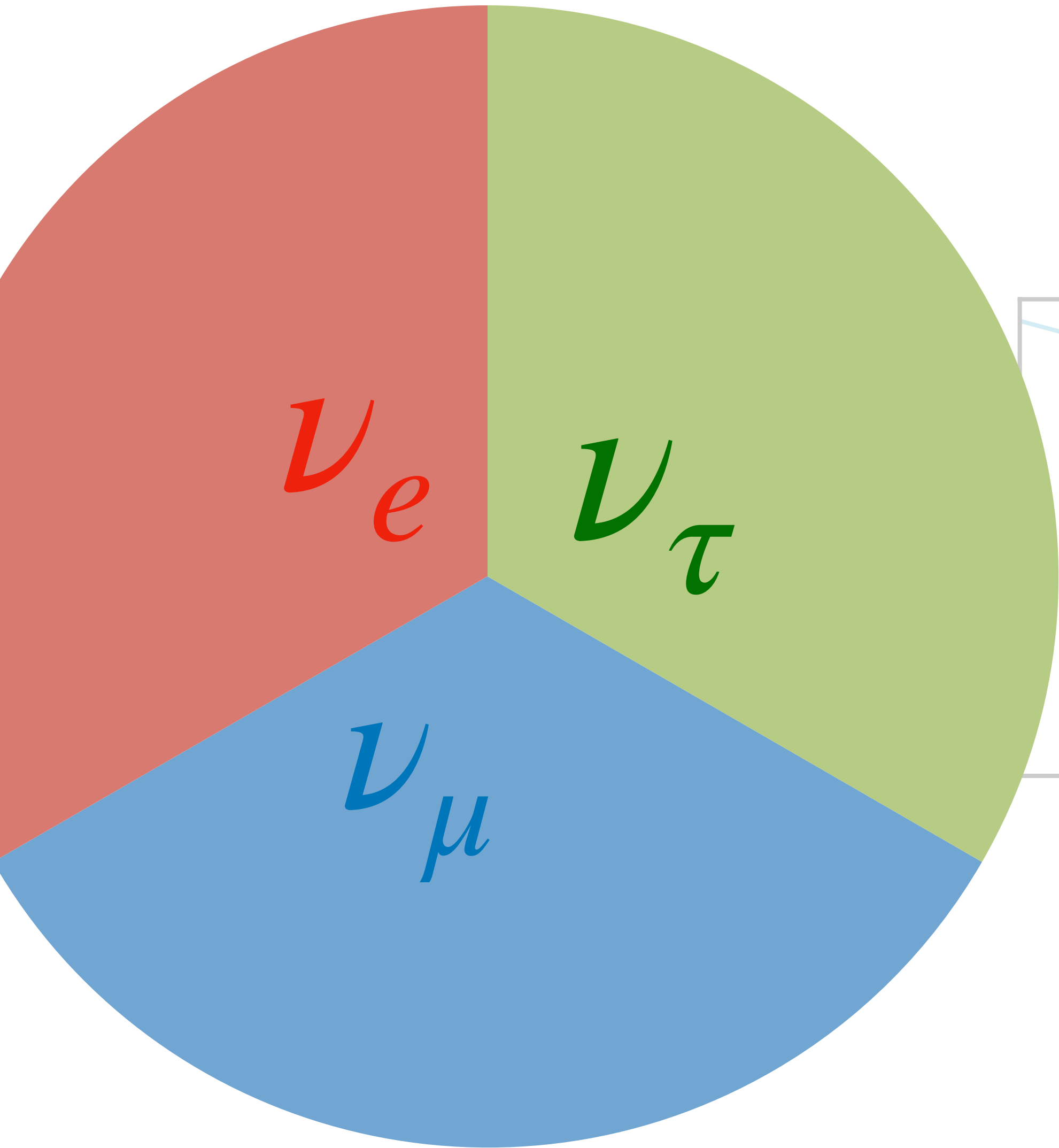

# What Do we look for

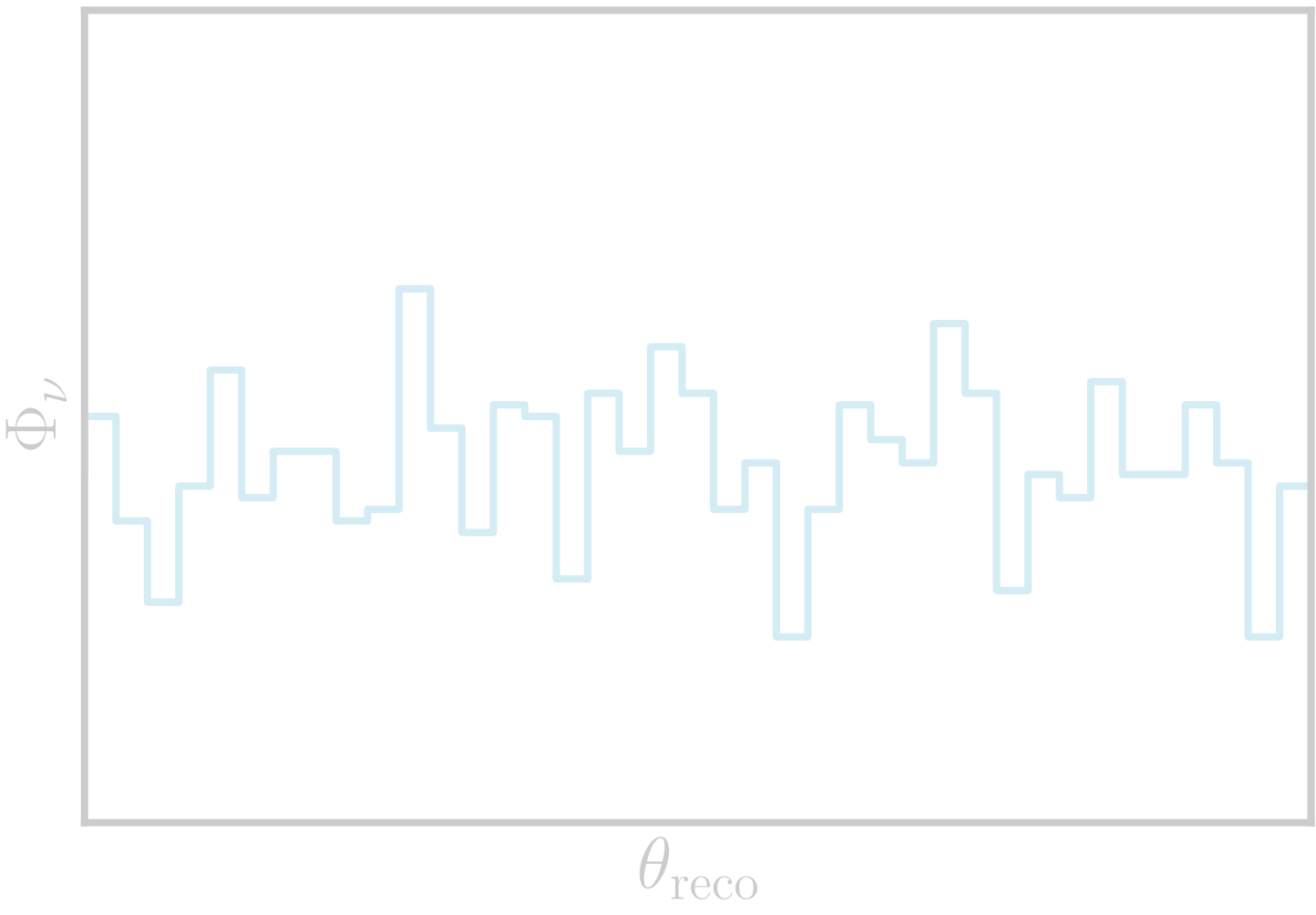
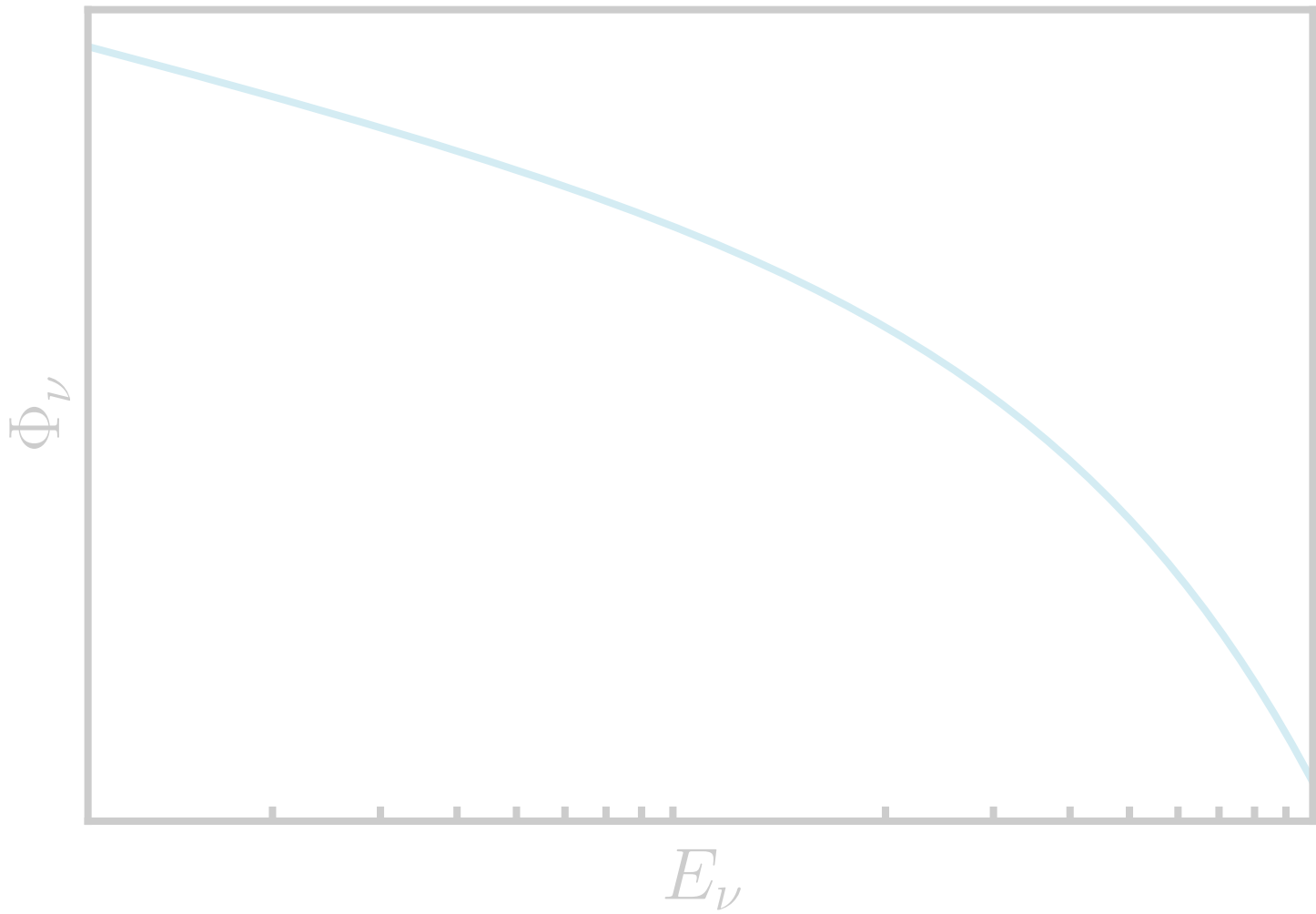
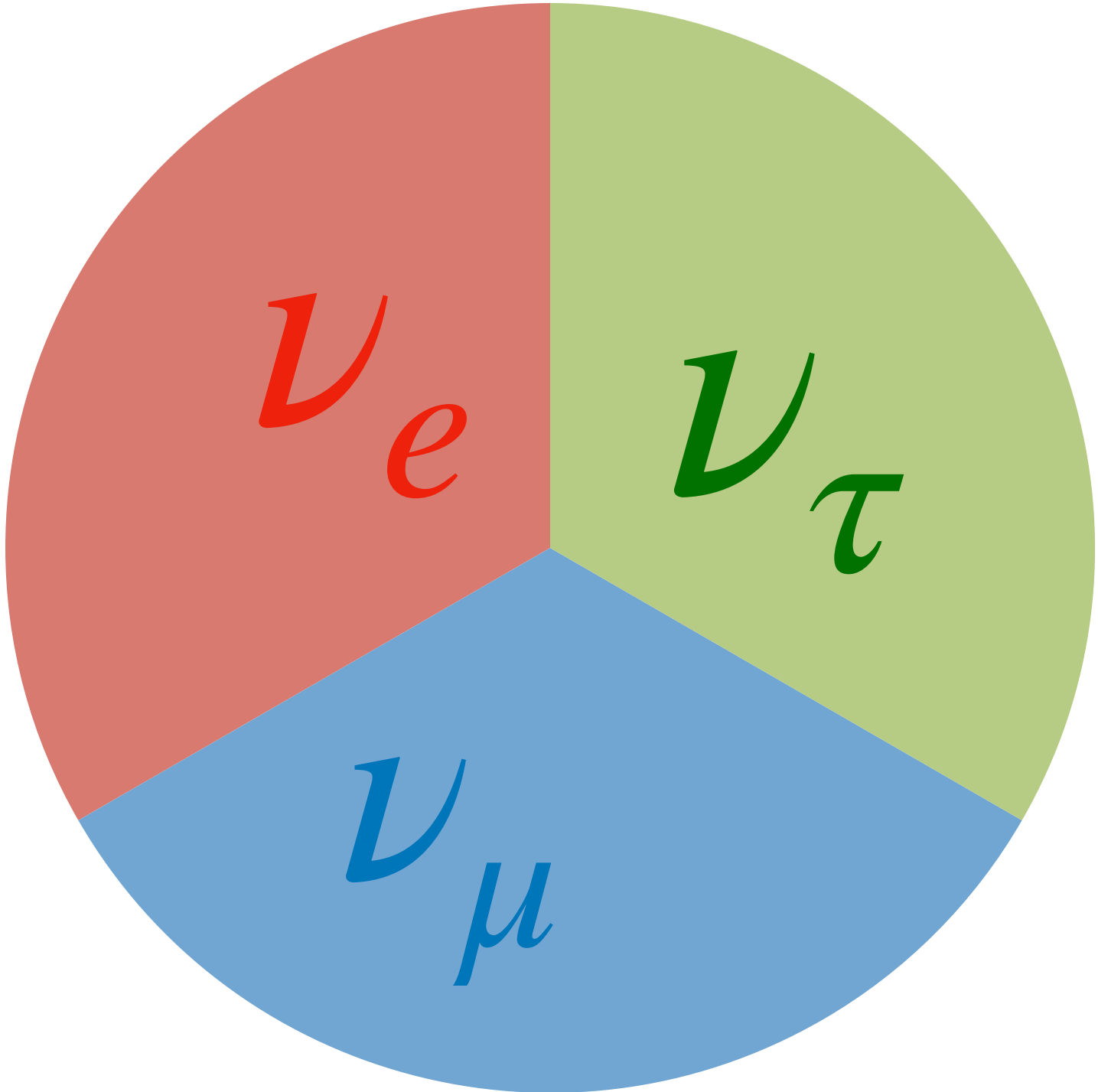

# What Do we look for

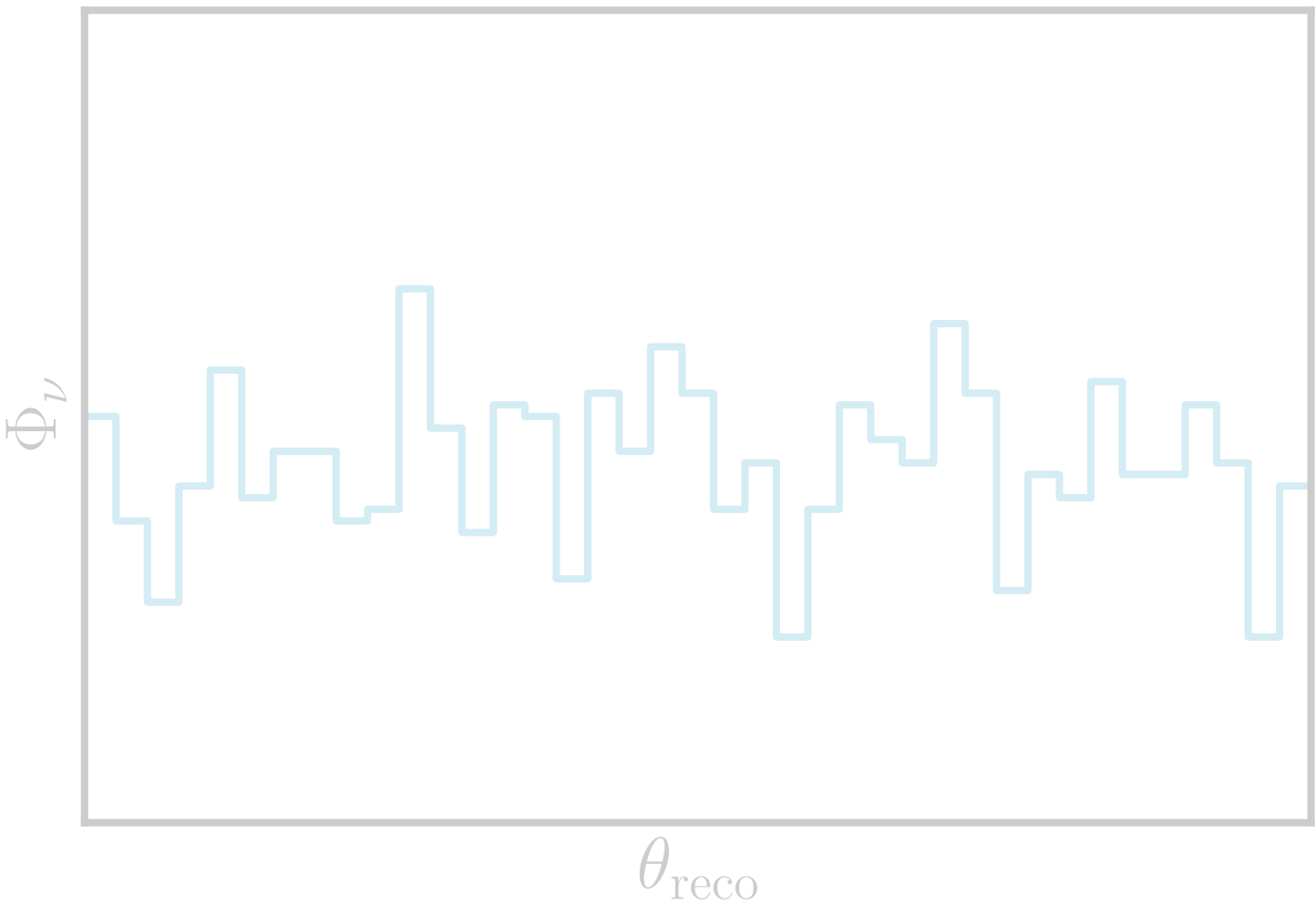
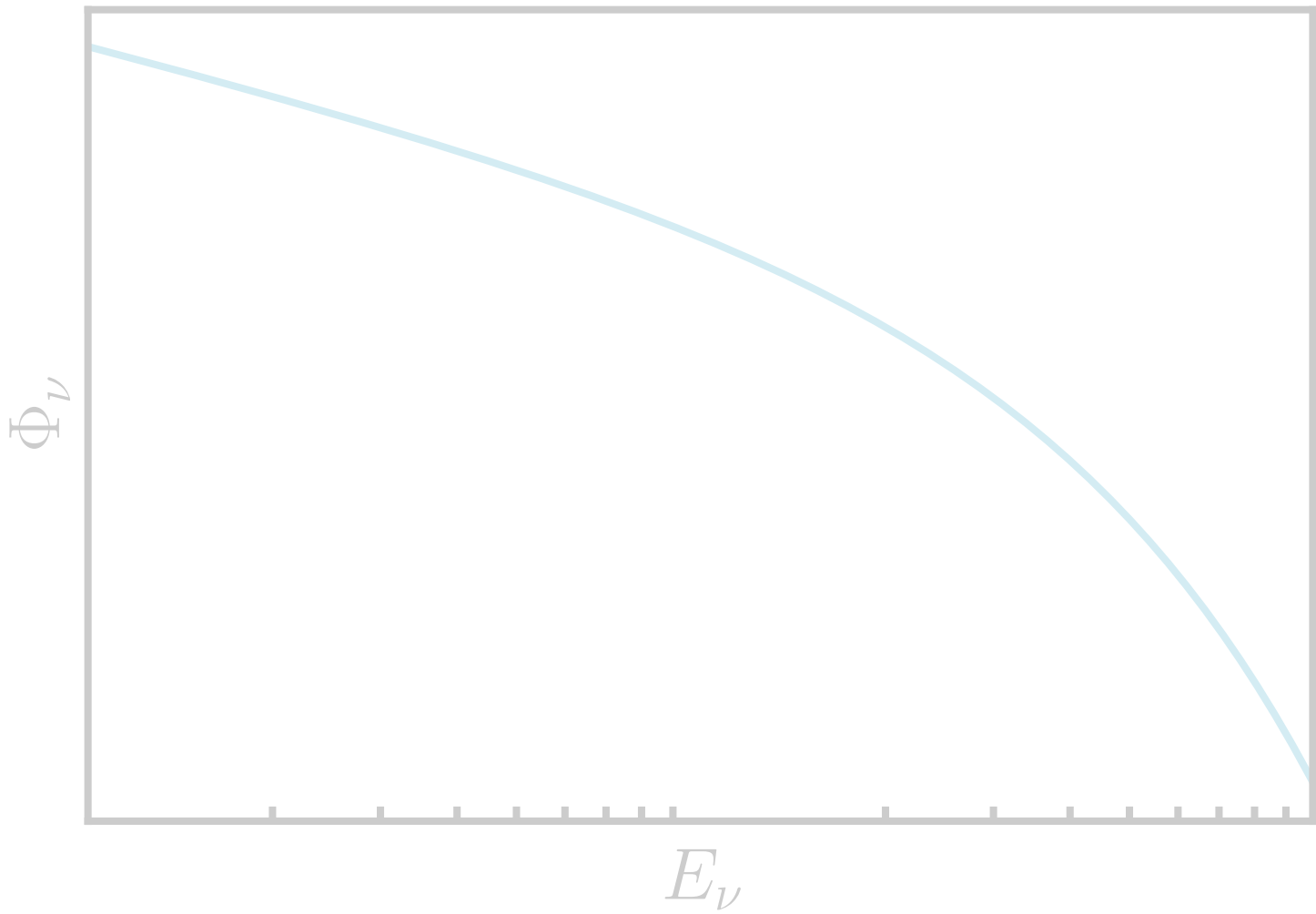
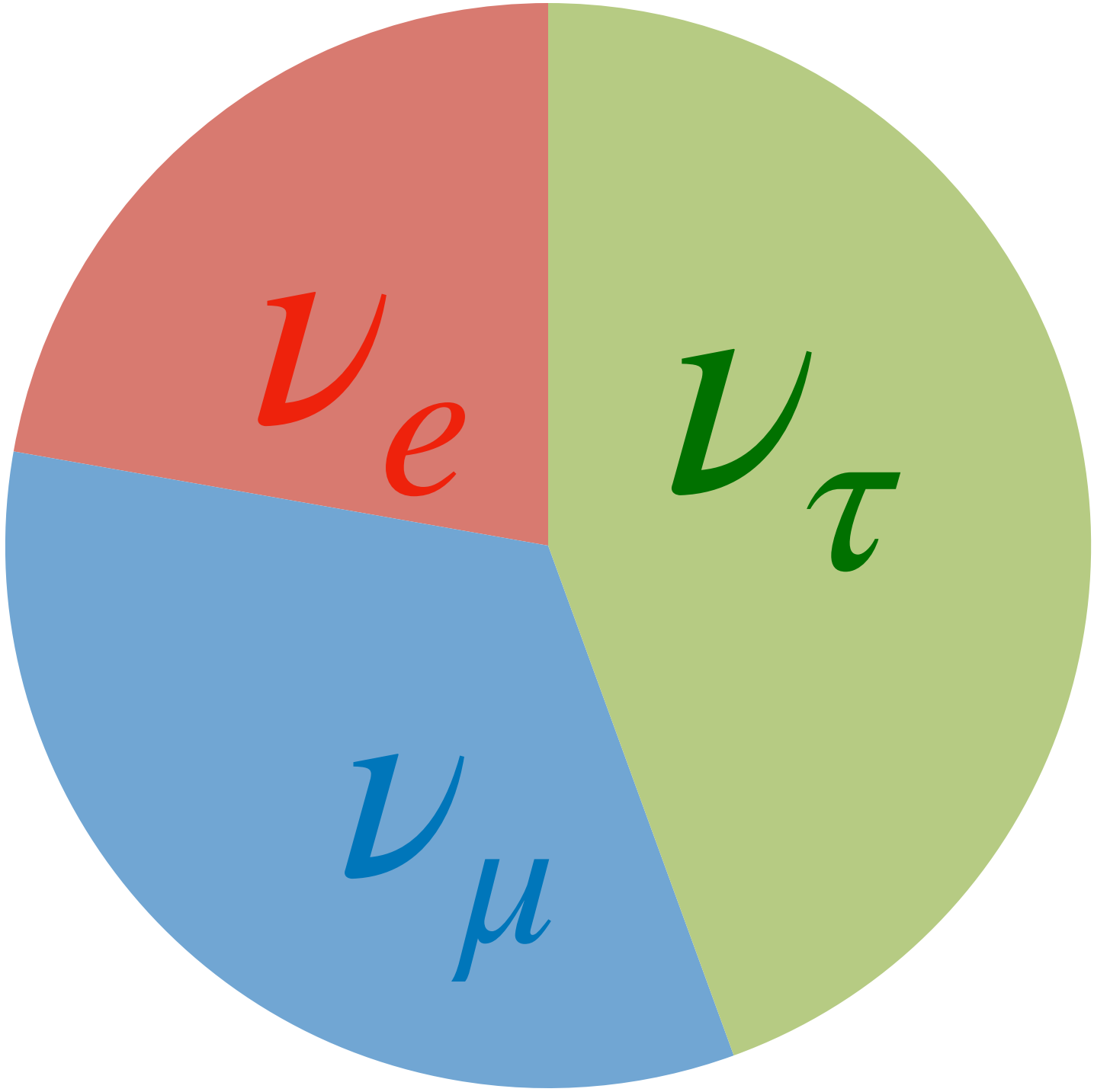

# What Do we look for

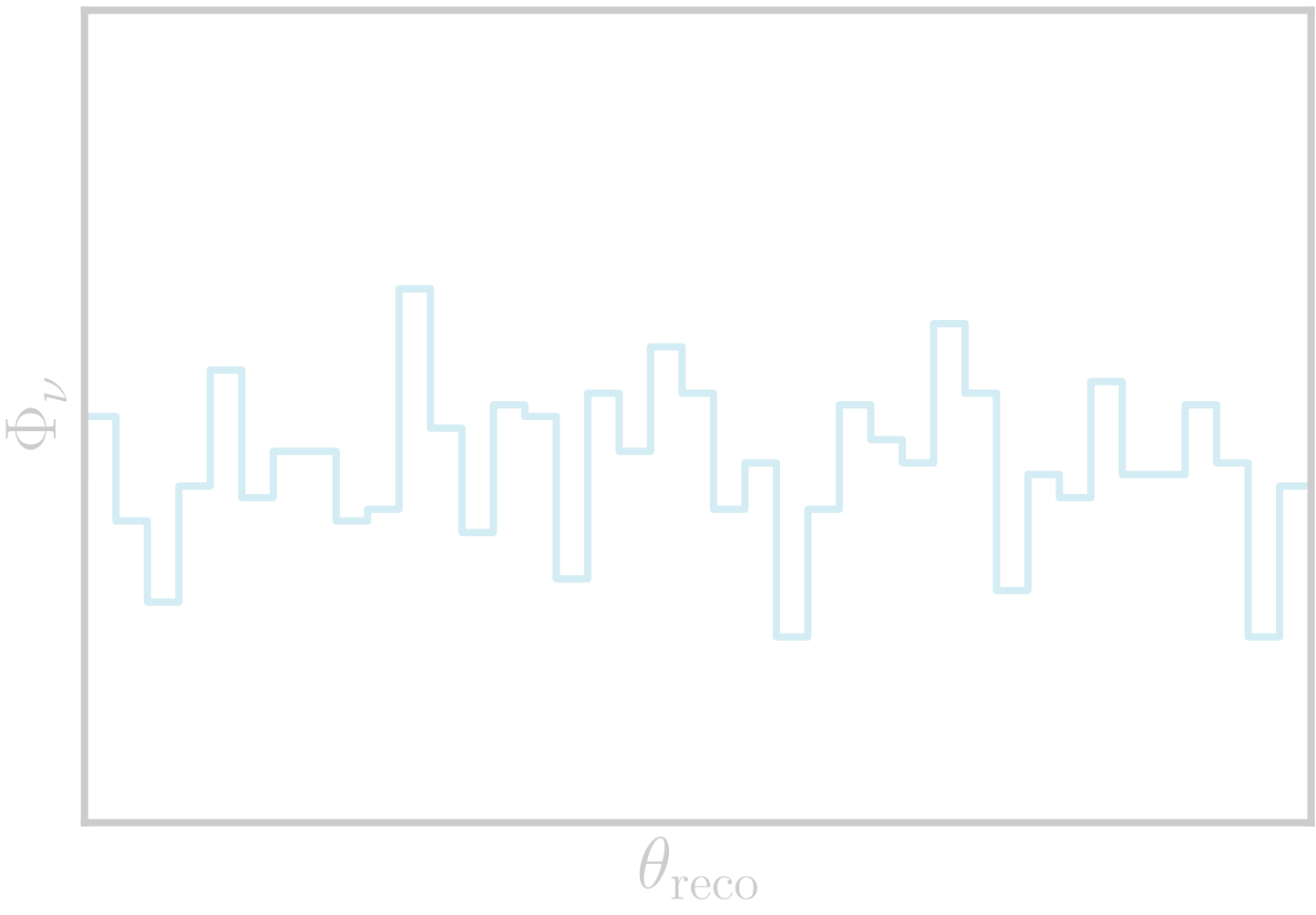
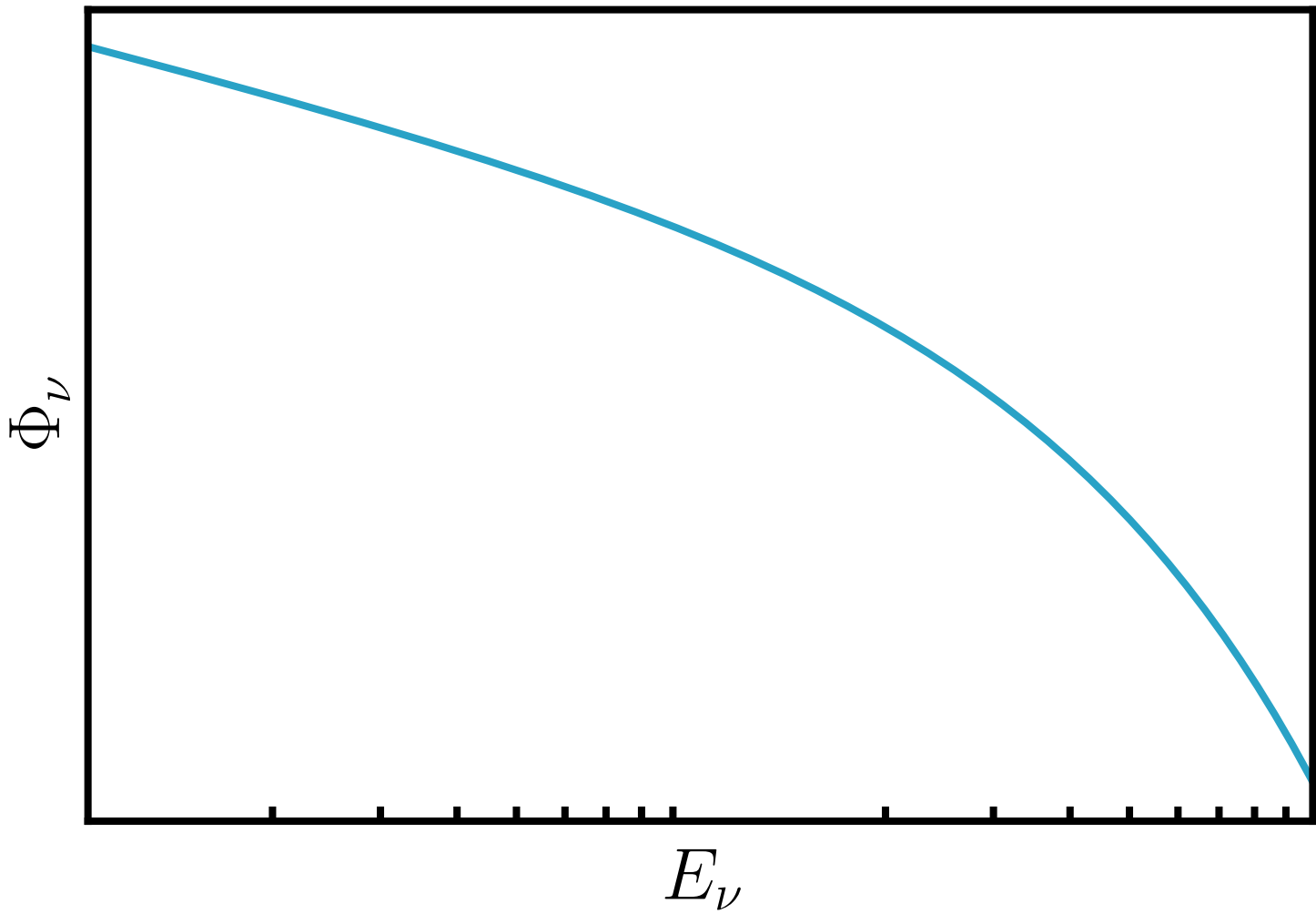
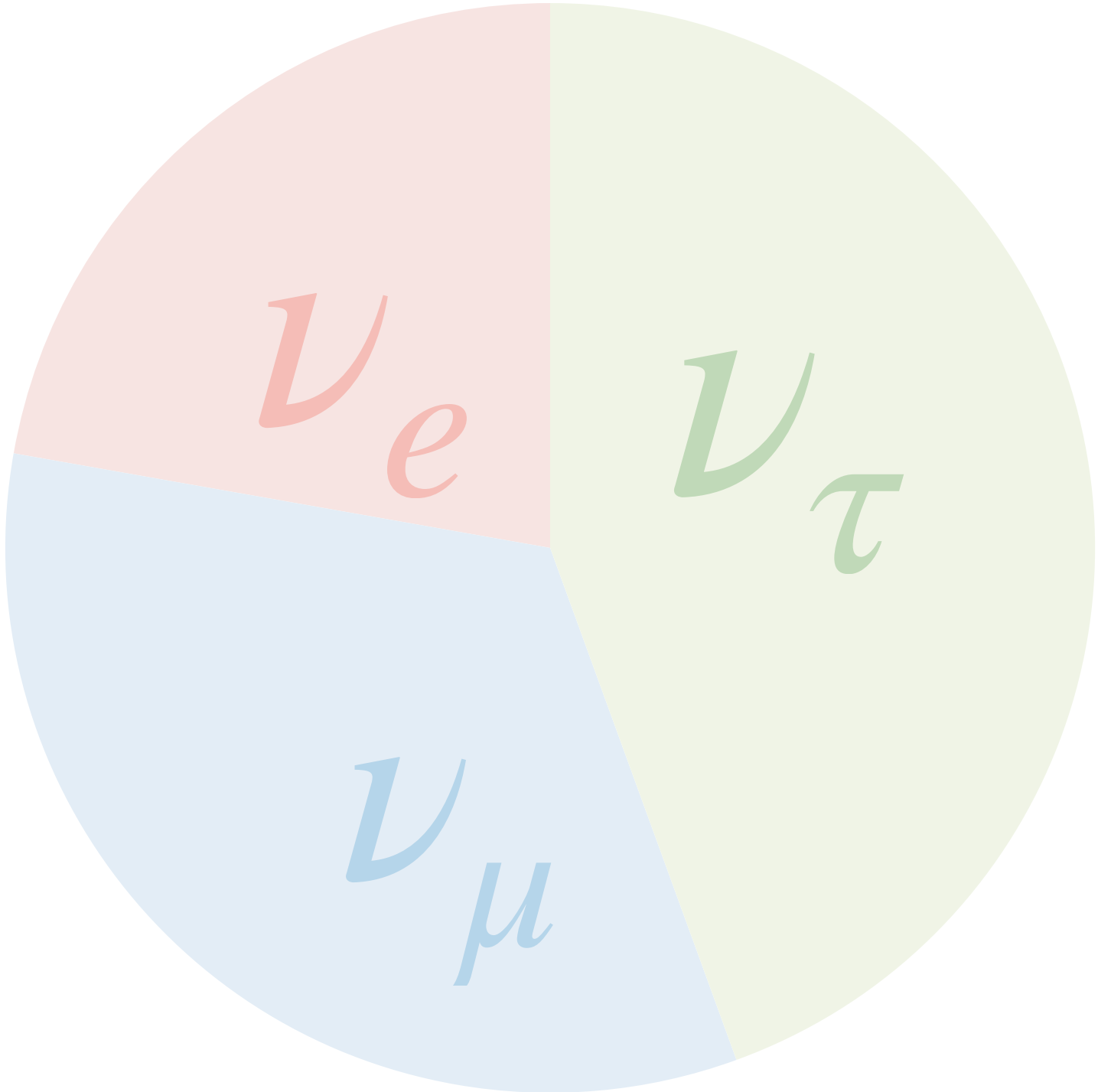

# What Do we look for

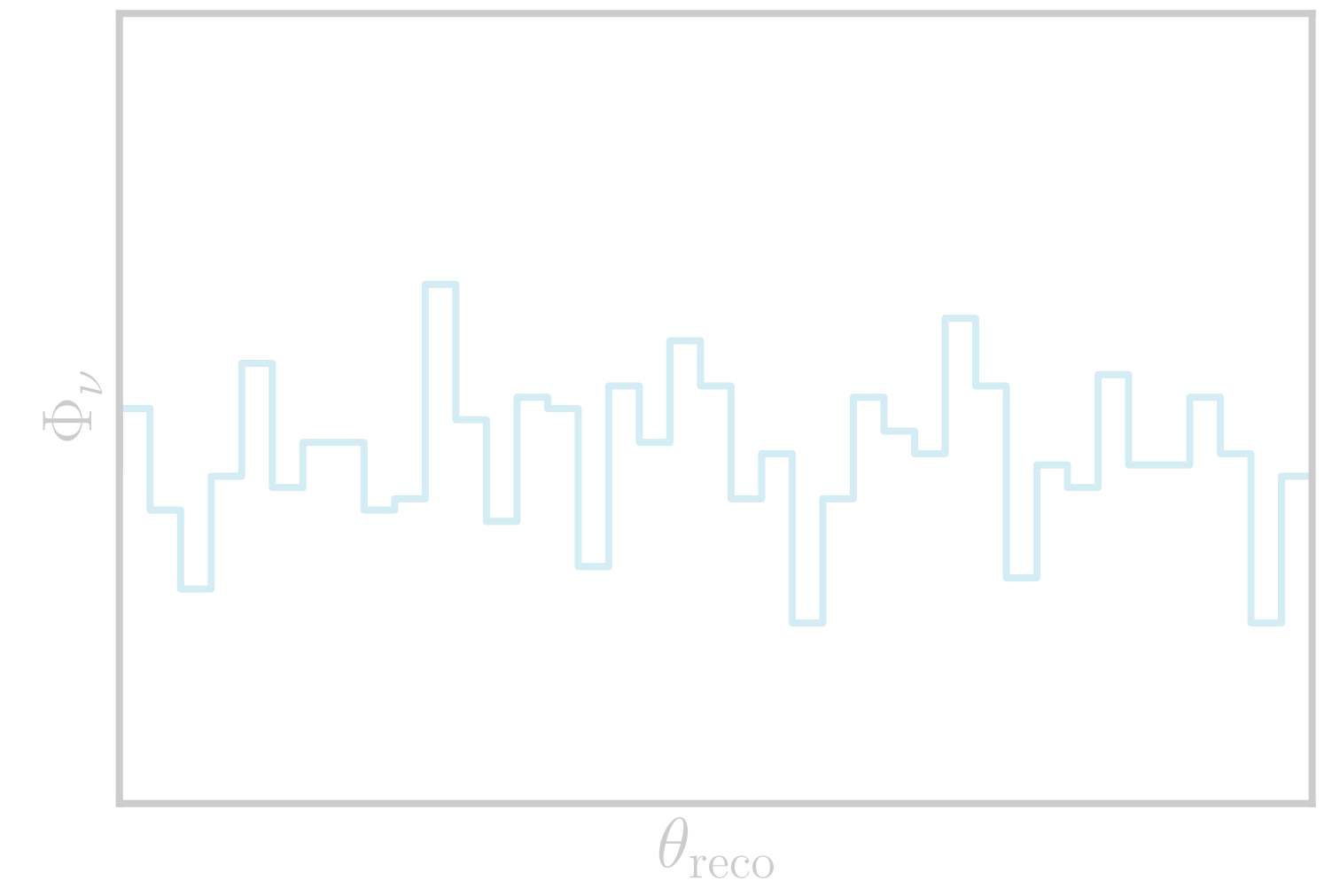
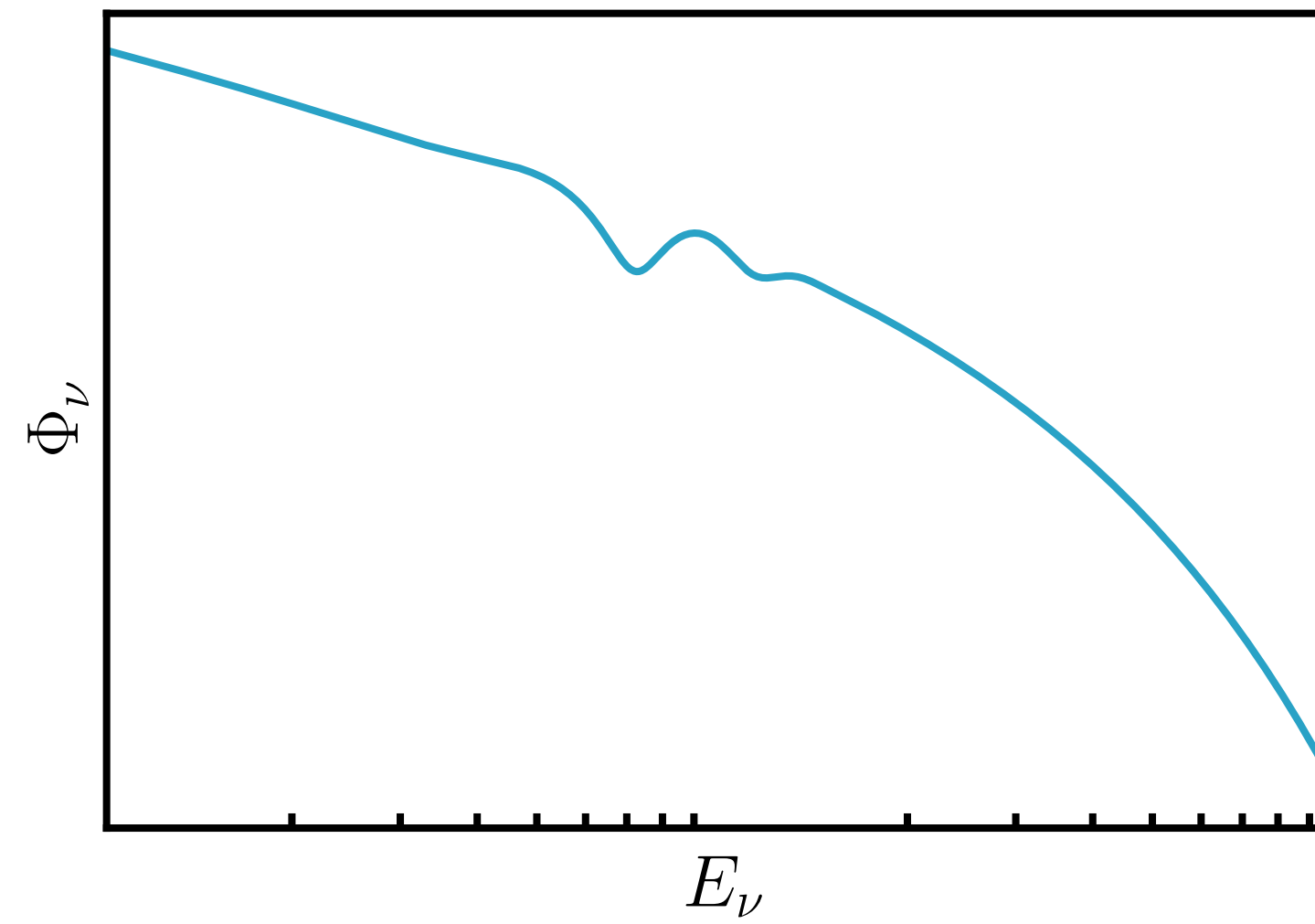
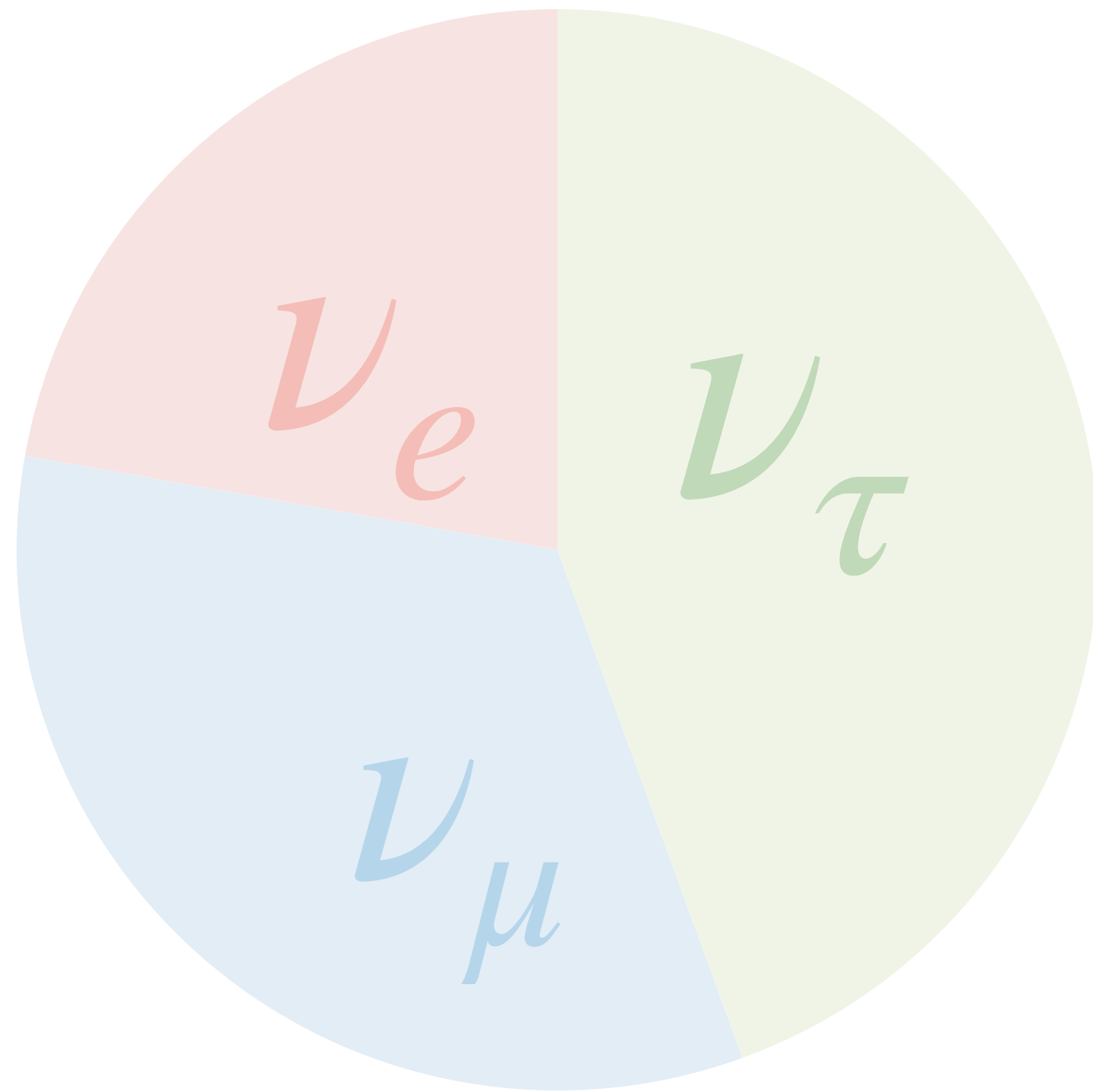

# What Do we look for

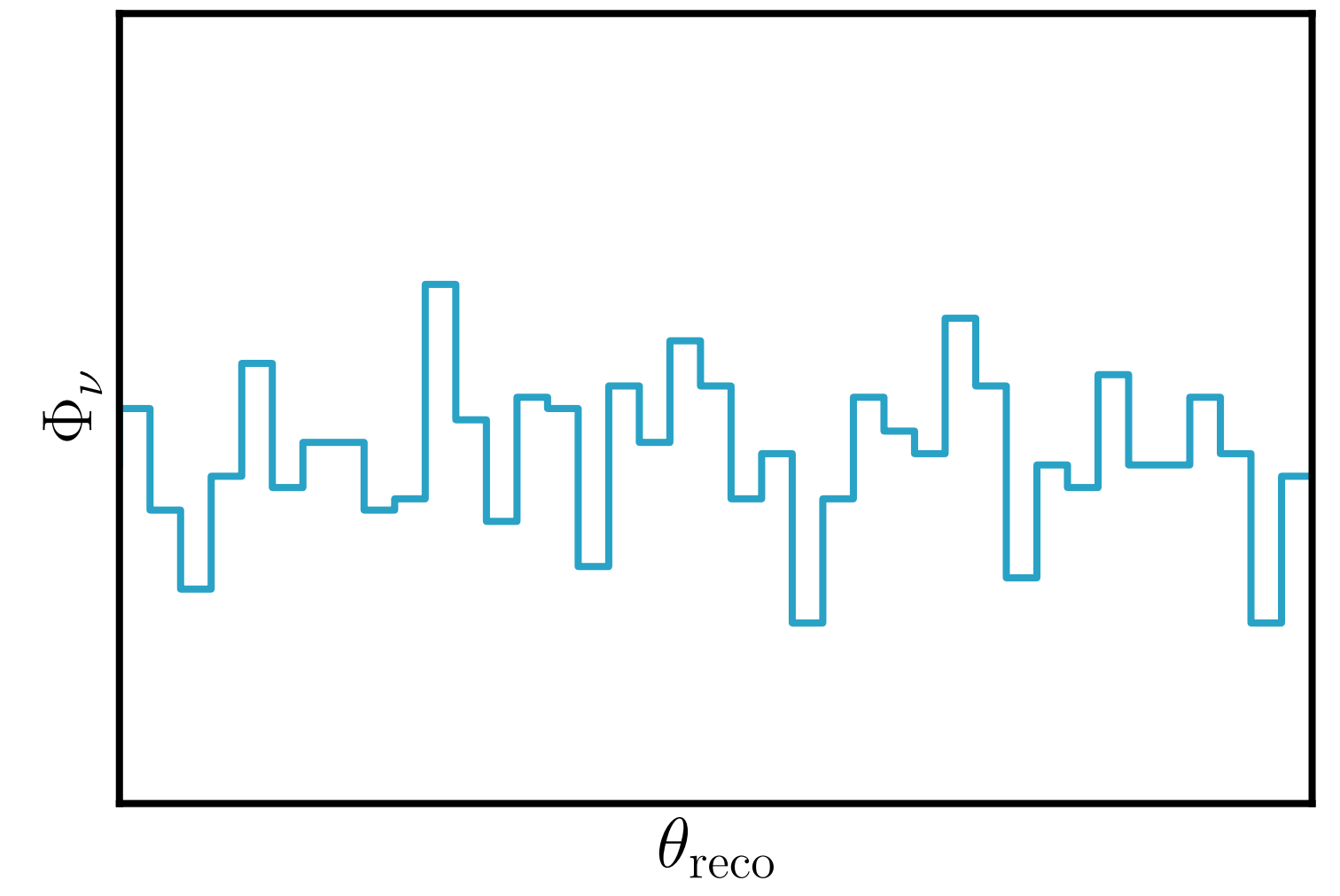
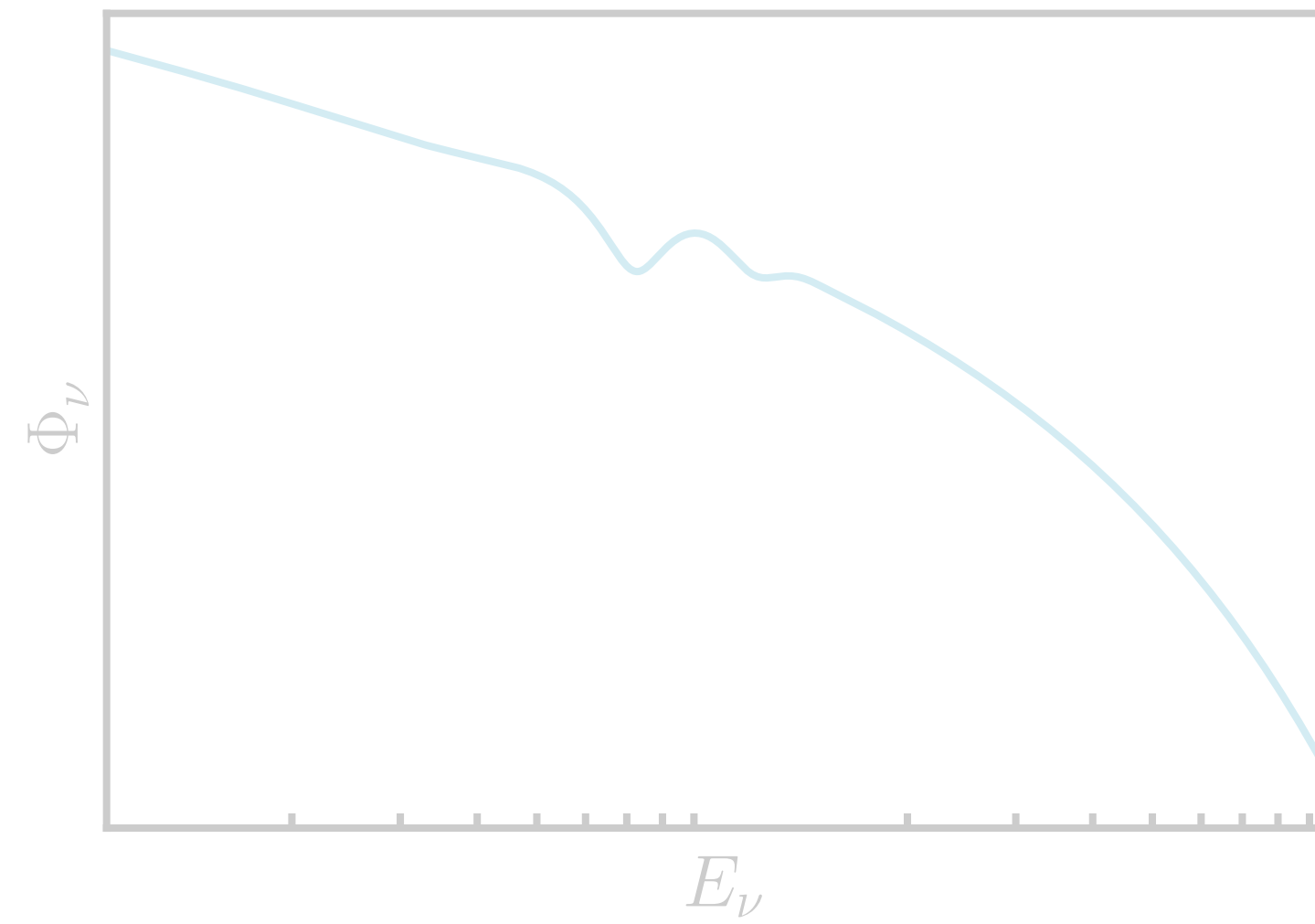
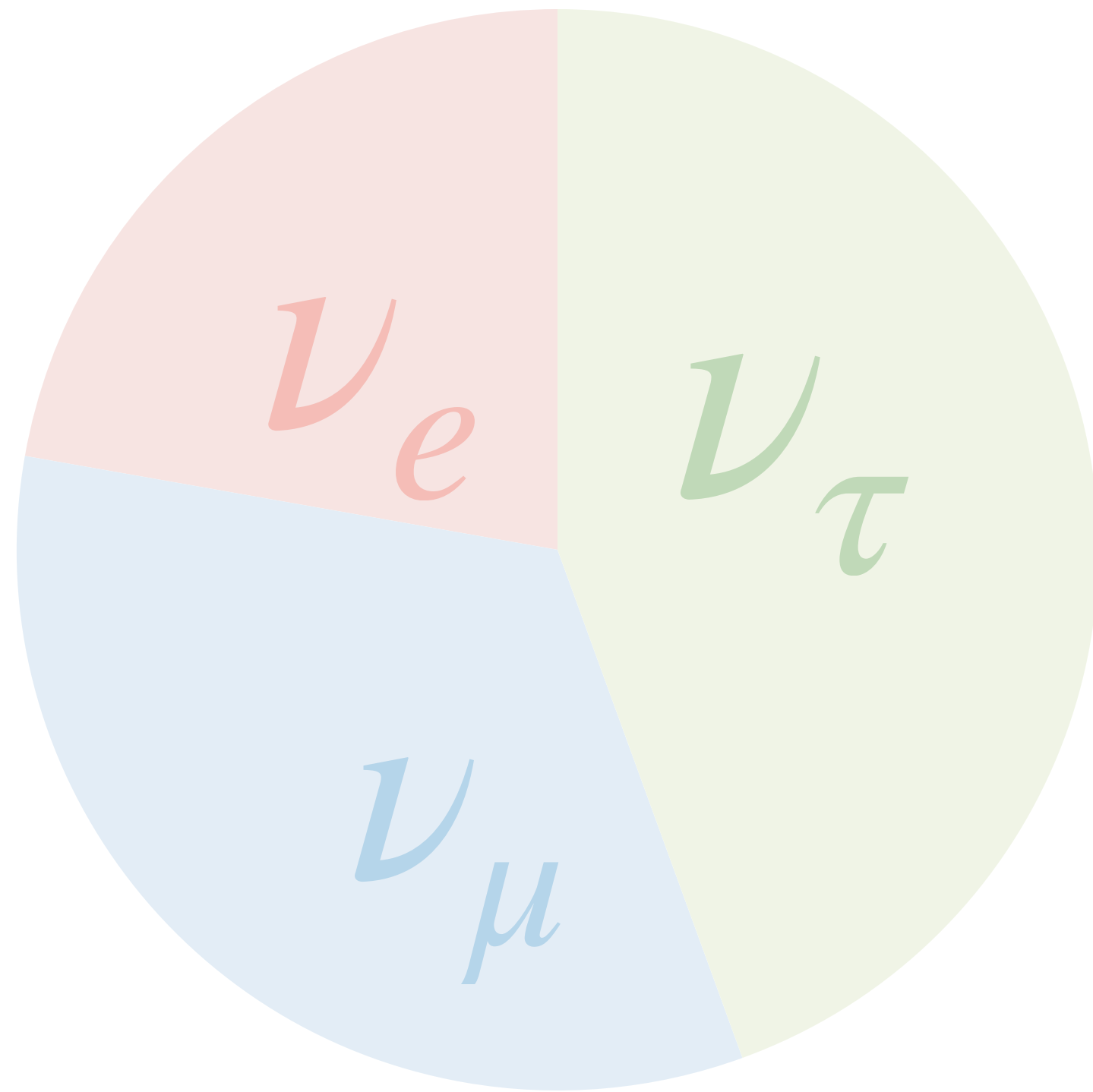

# What Do we look for

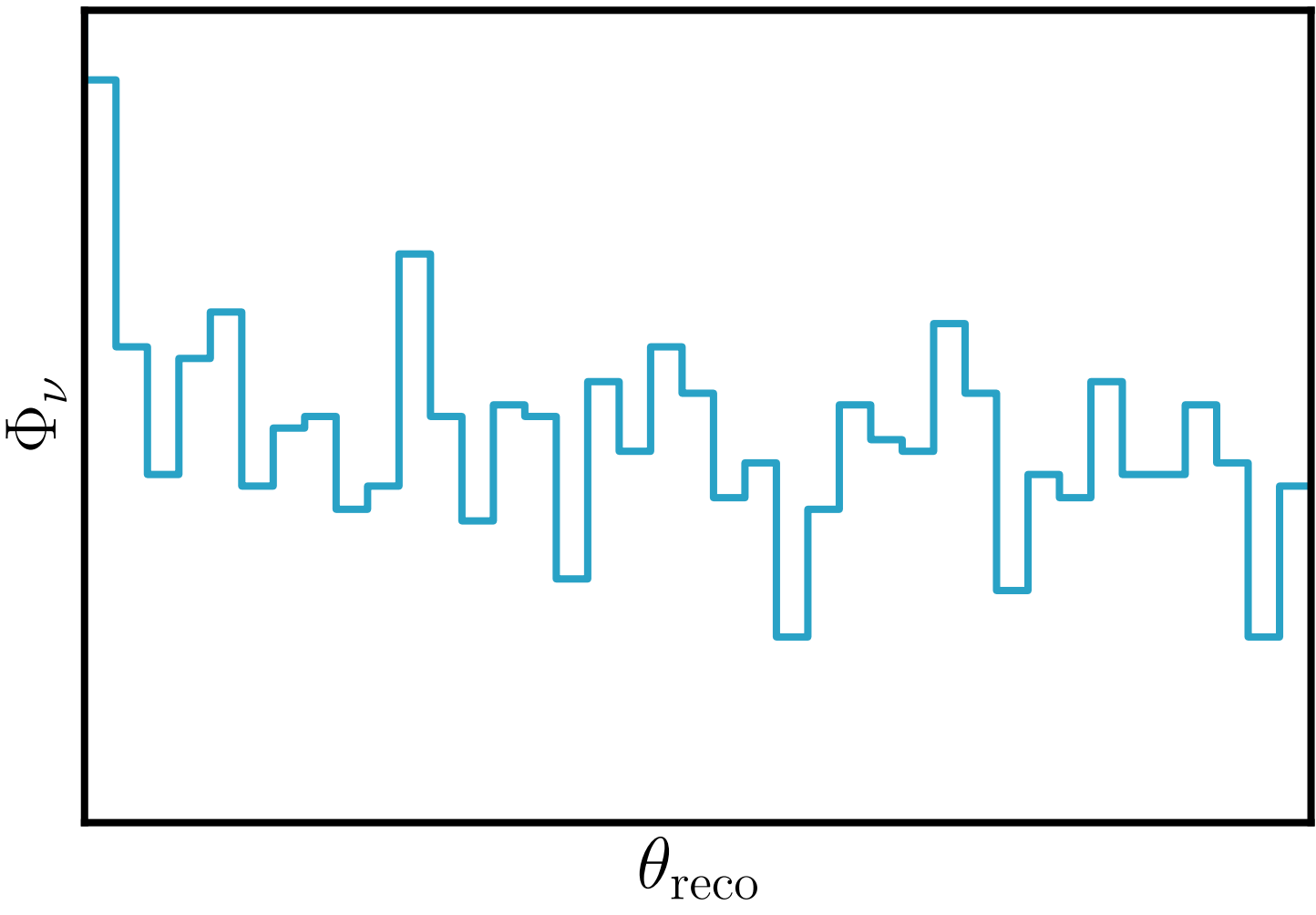
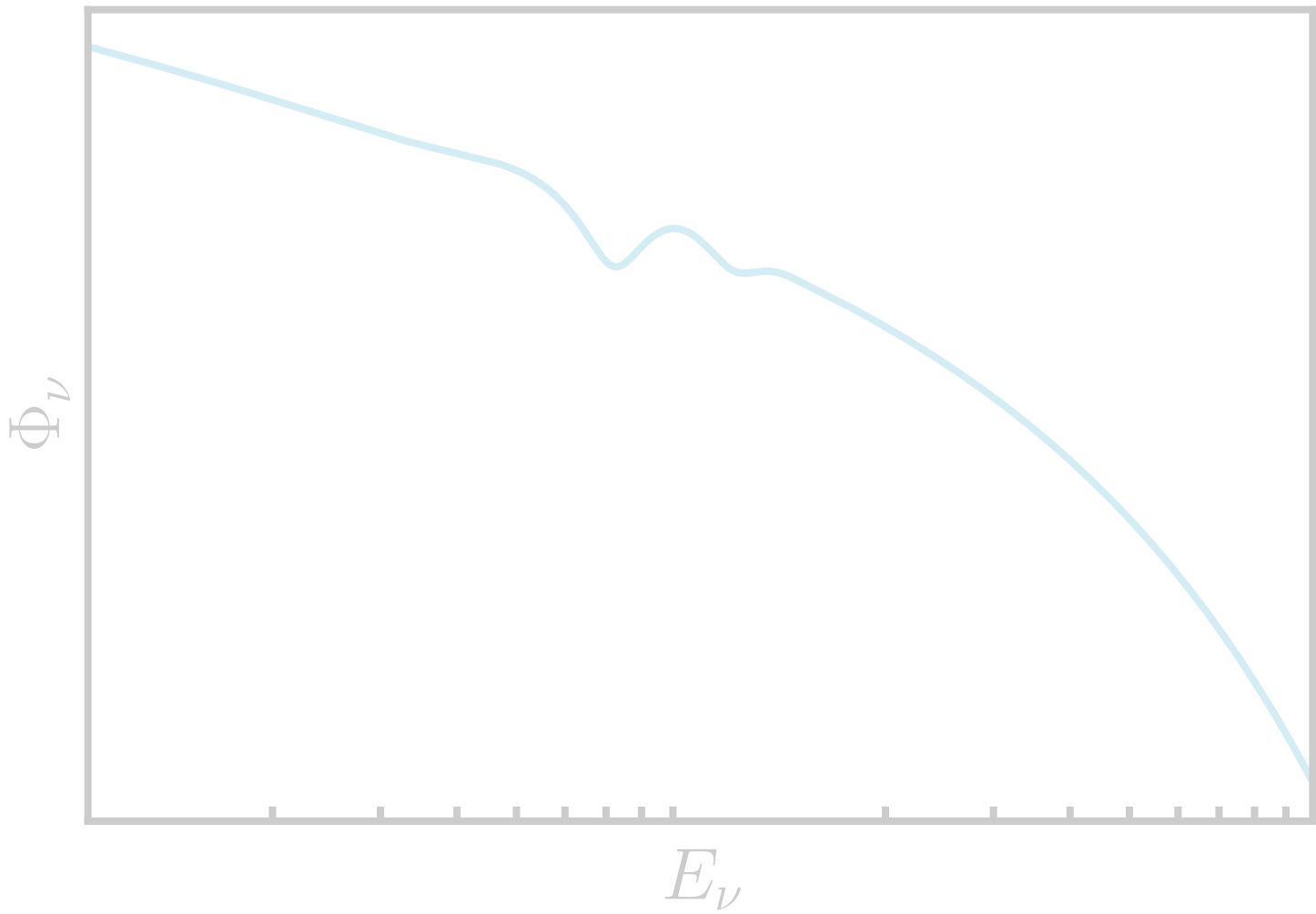
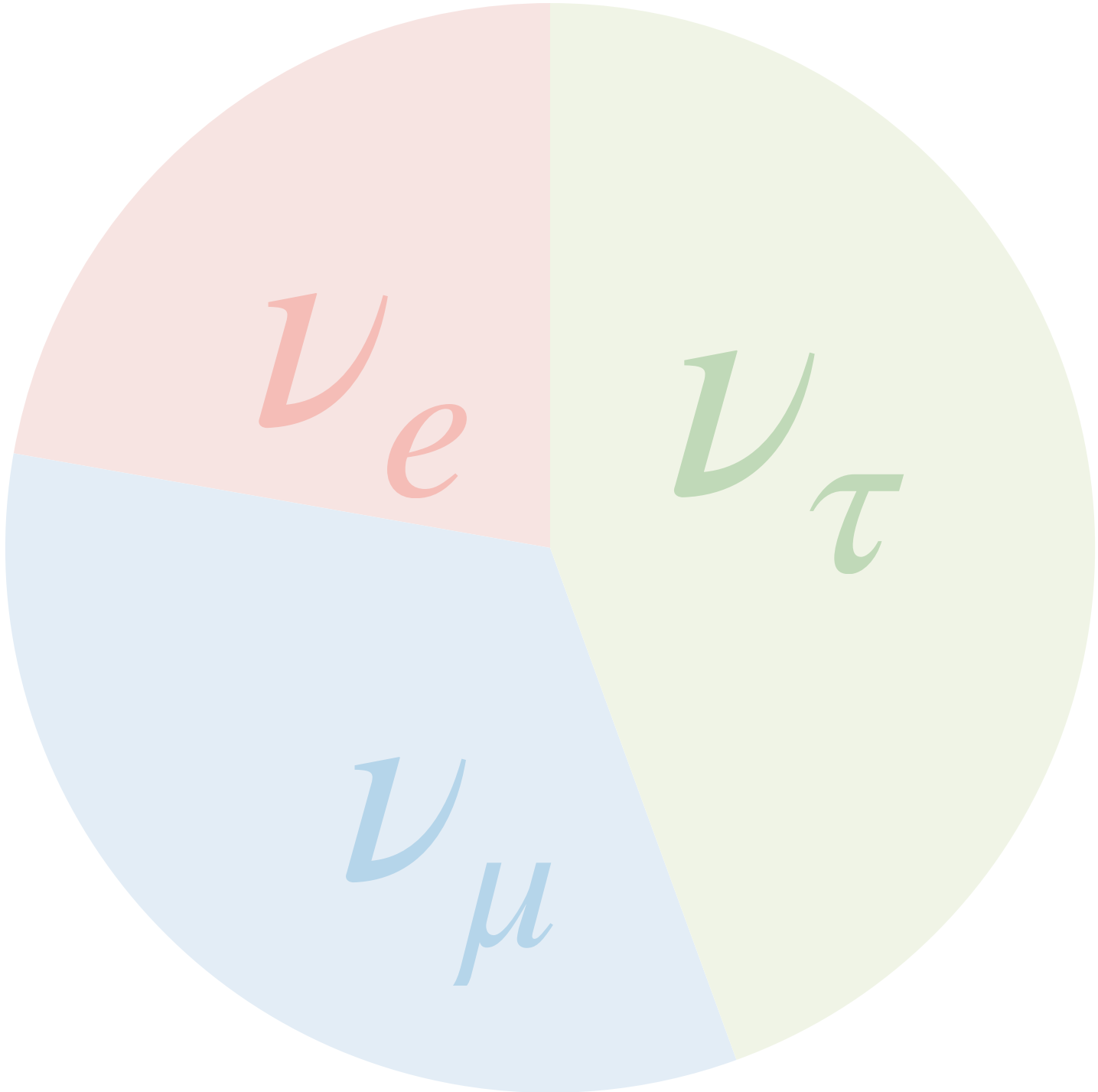

# A Decade of Delivering



# A Decade of Delivering

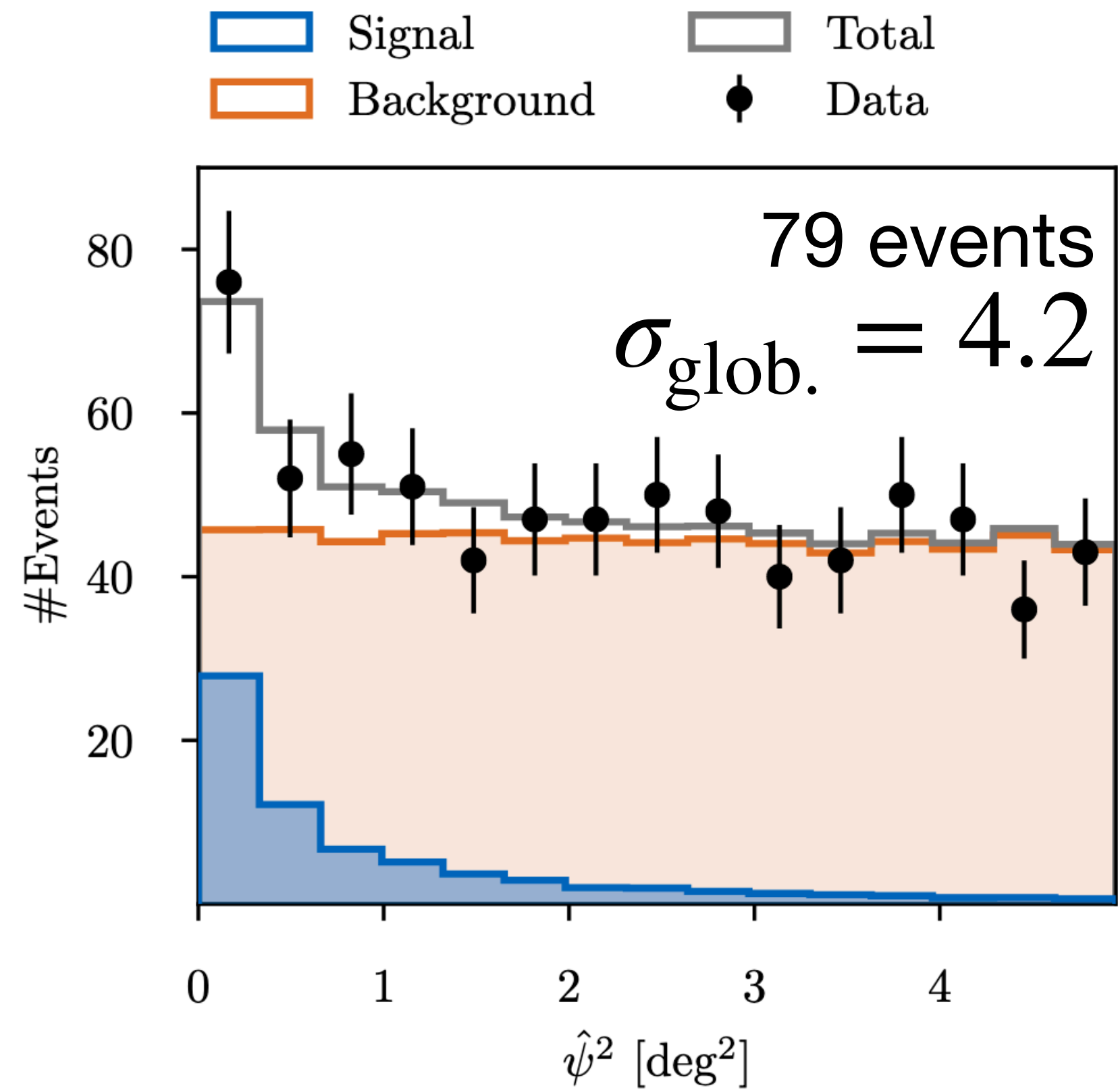

# A Decade of Delivering

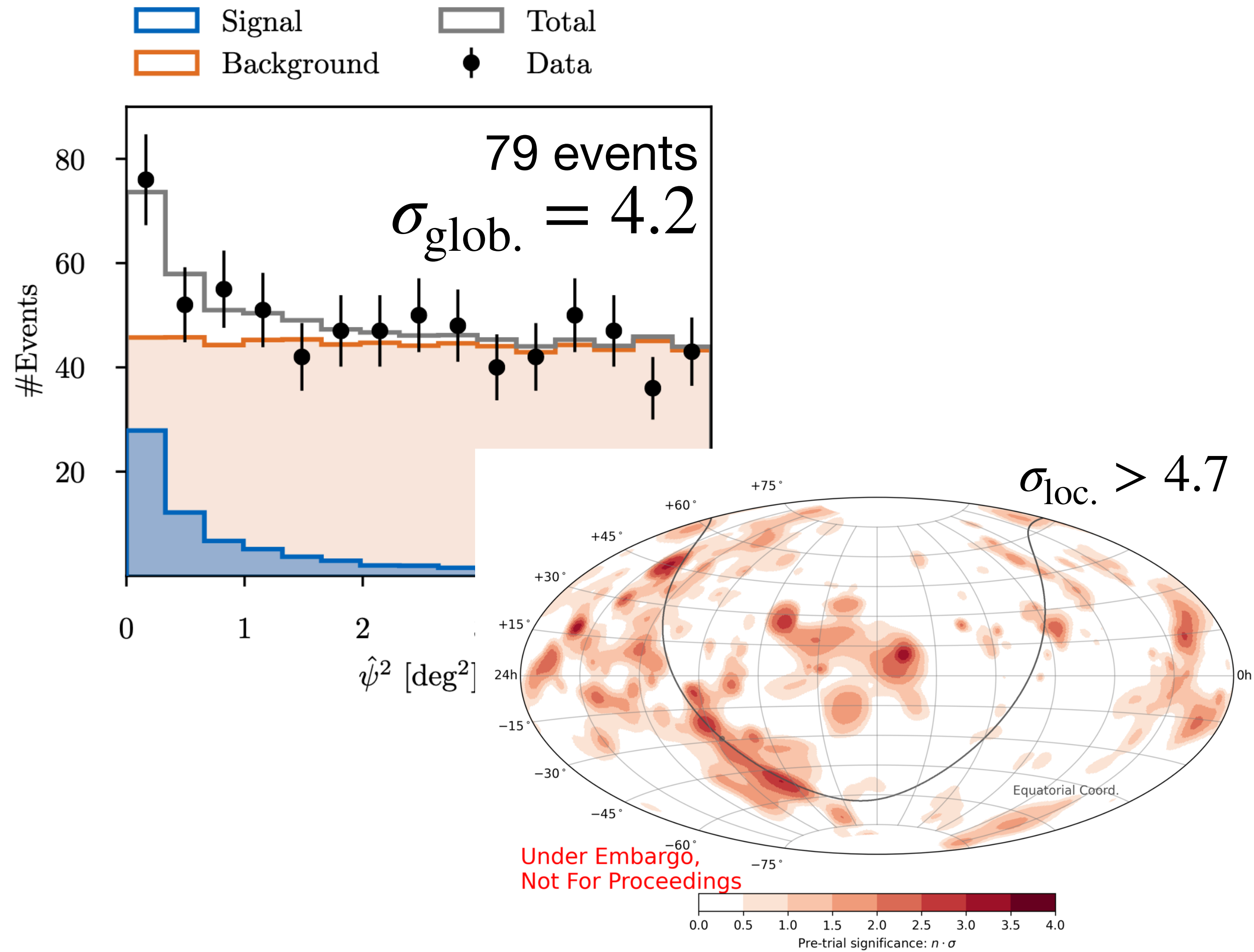

# A Decade of Delivering

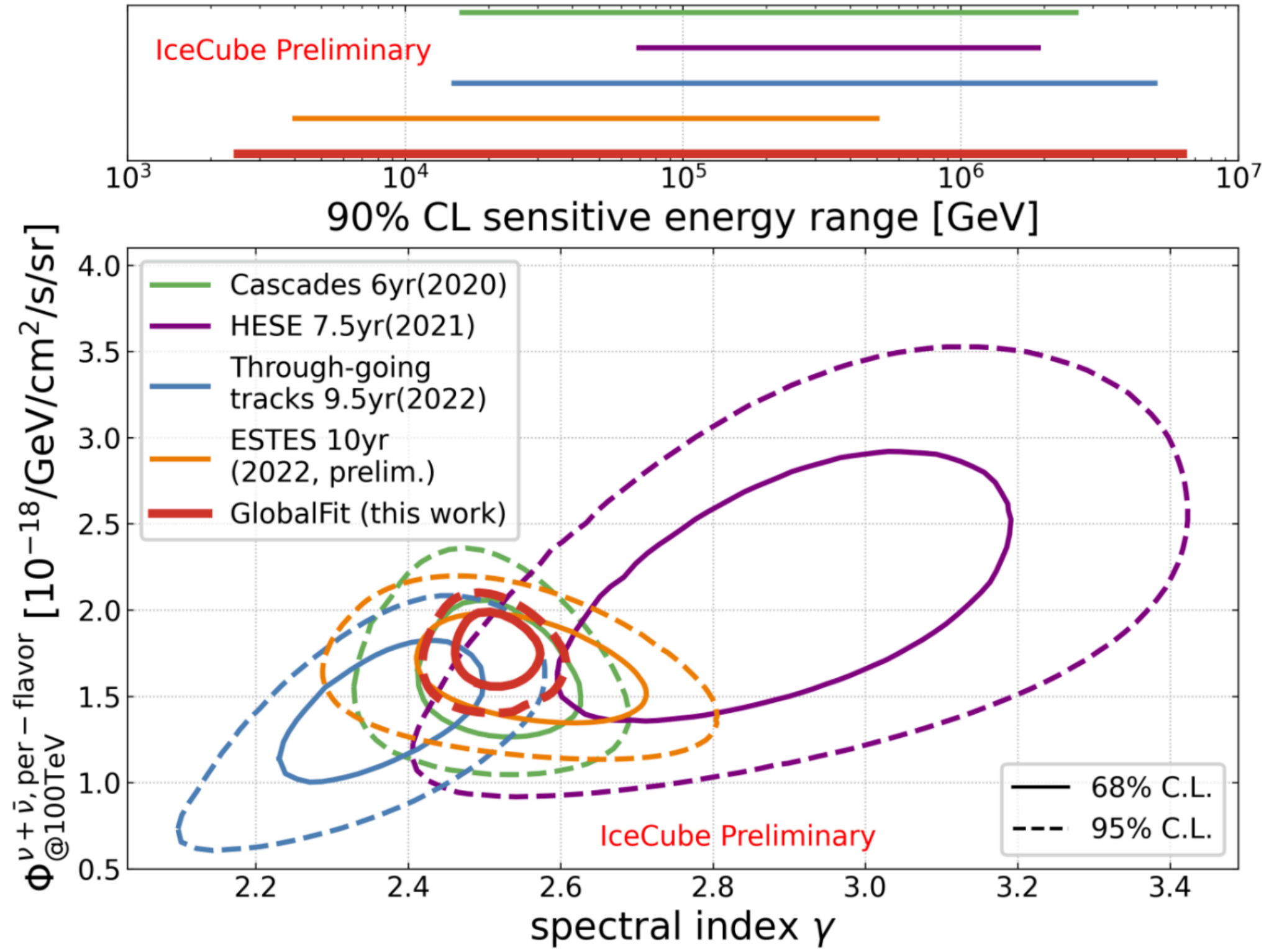
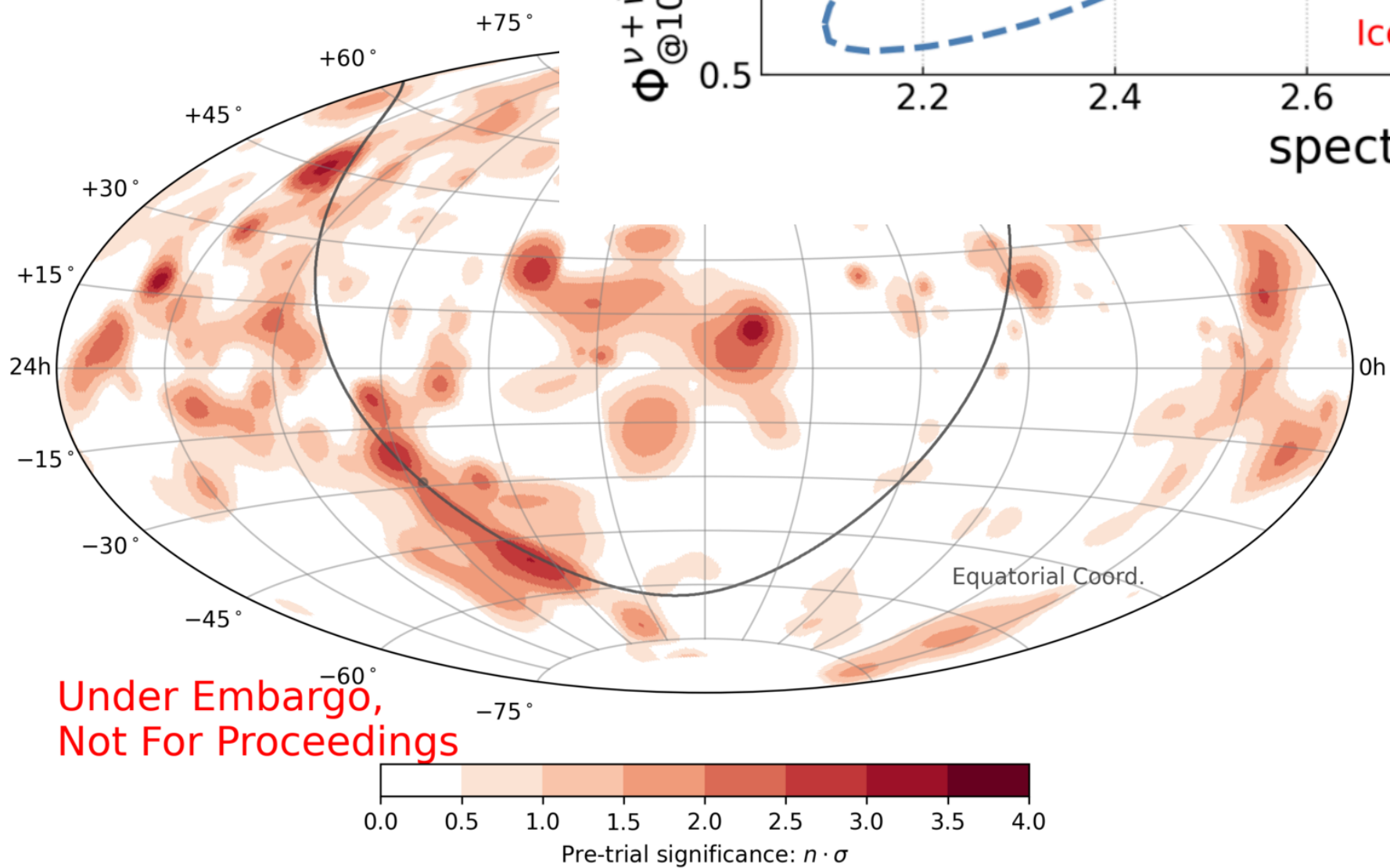
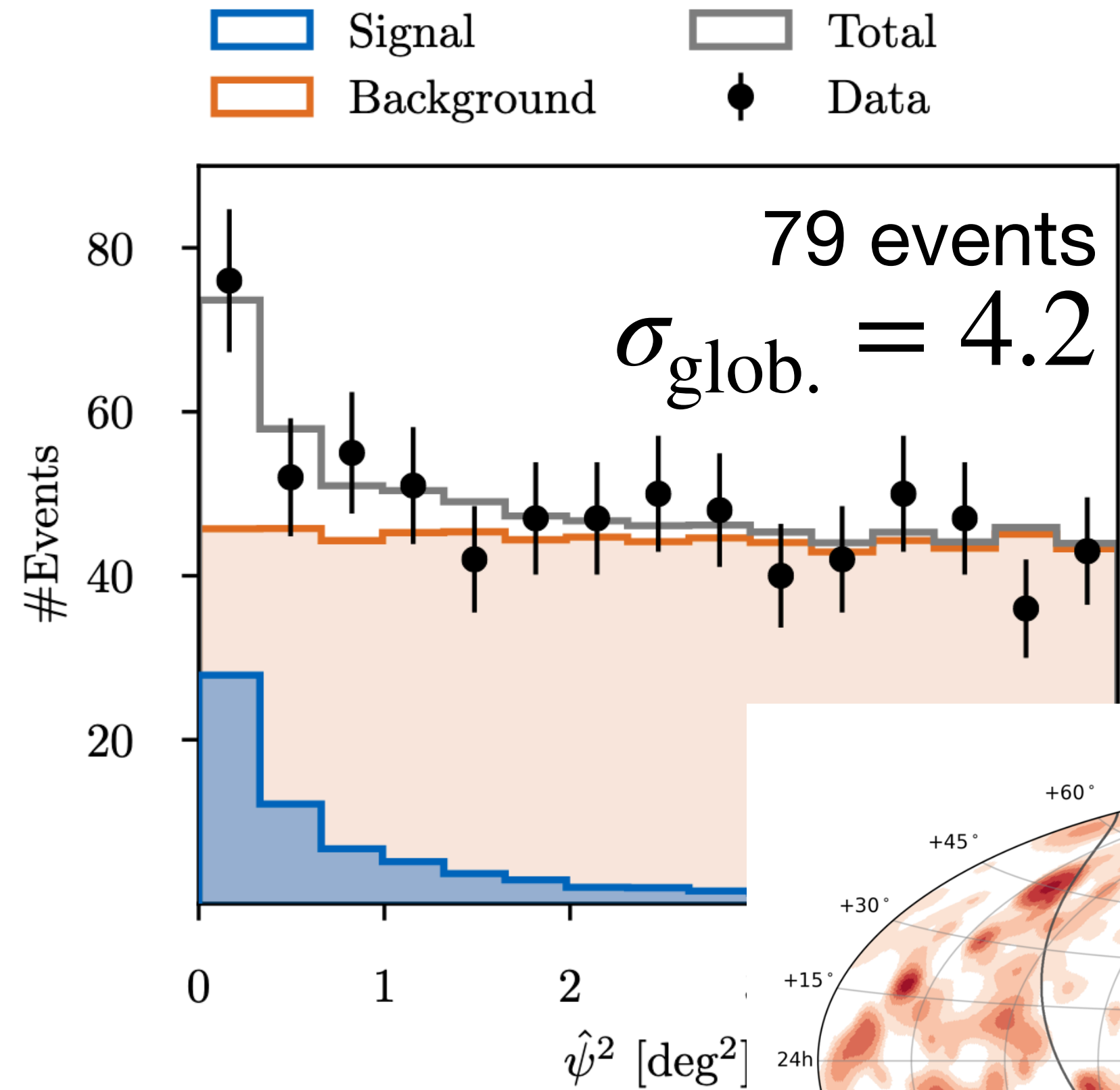

# A Decade of Delivering

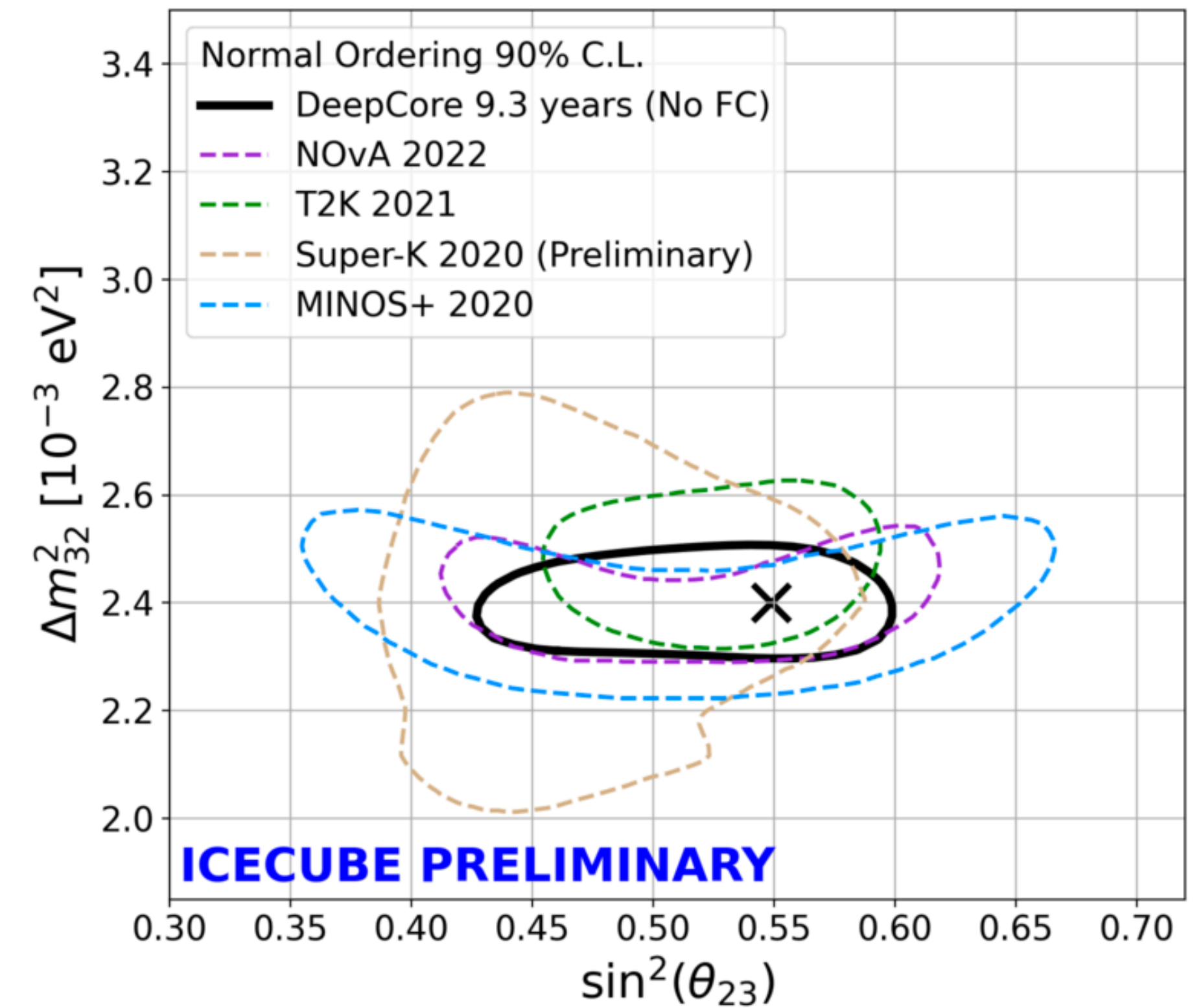
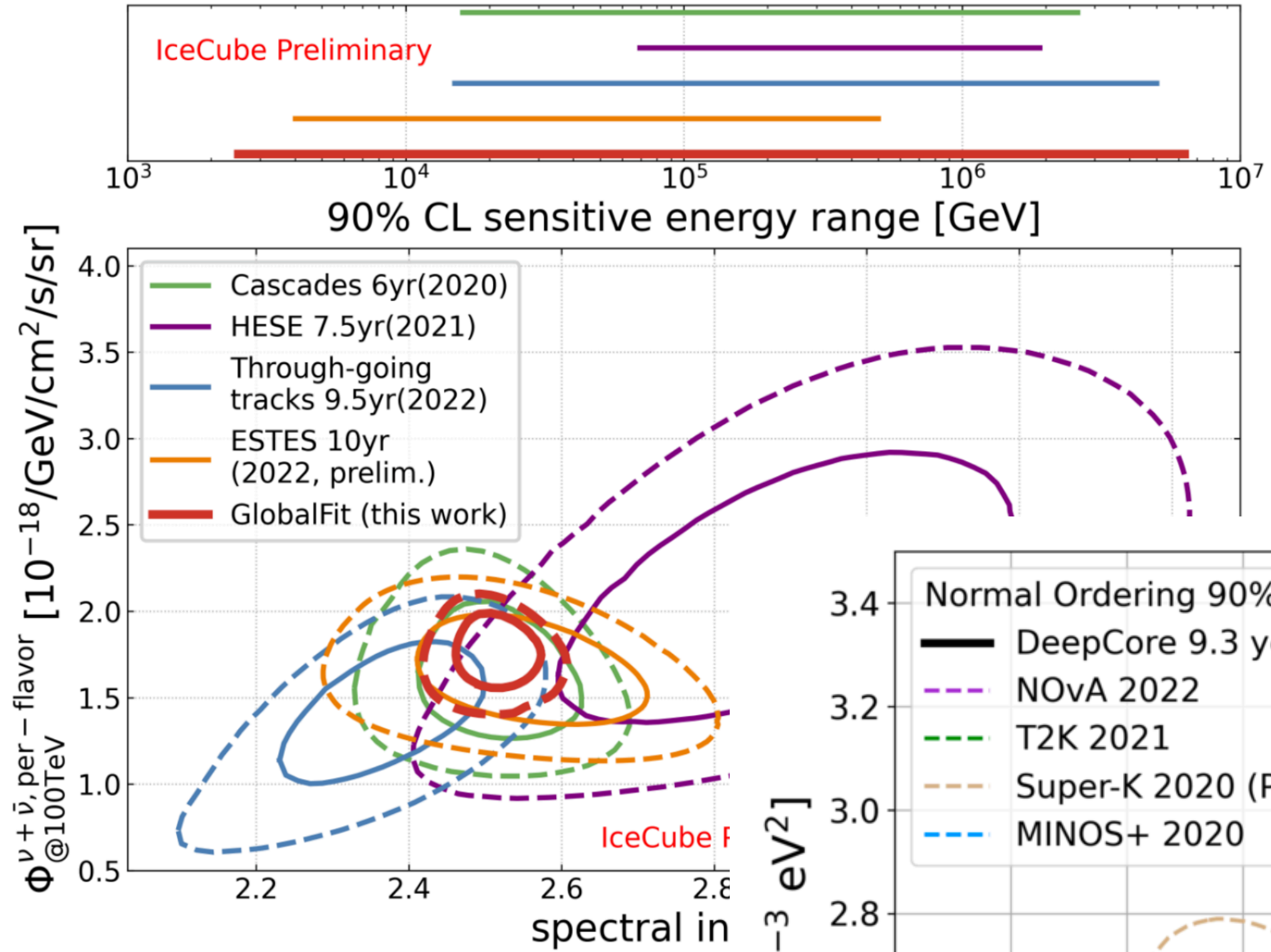
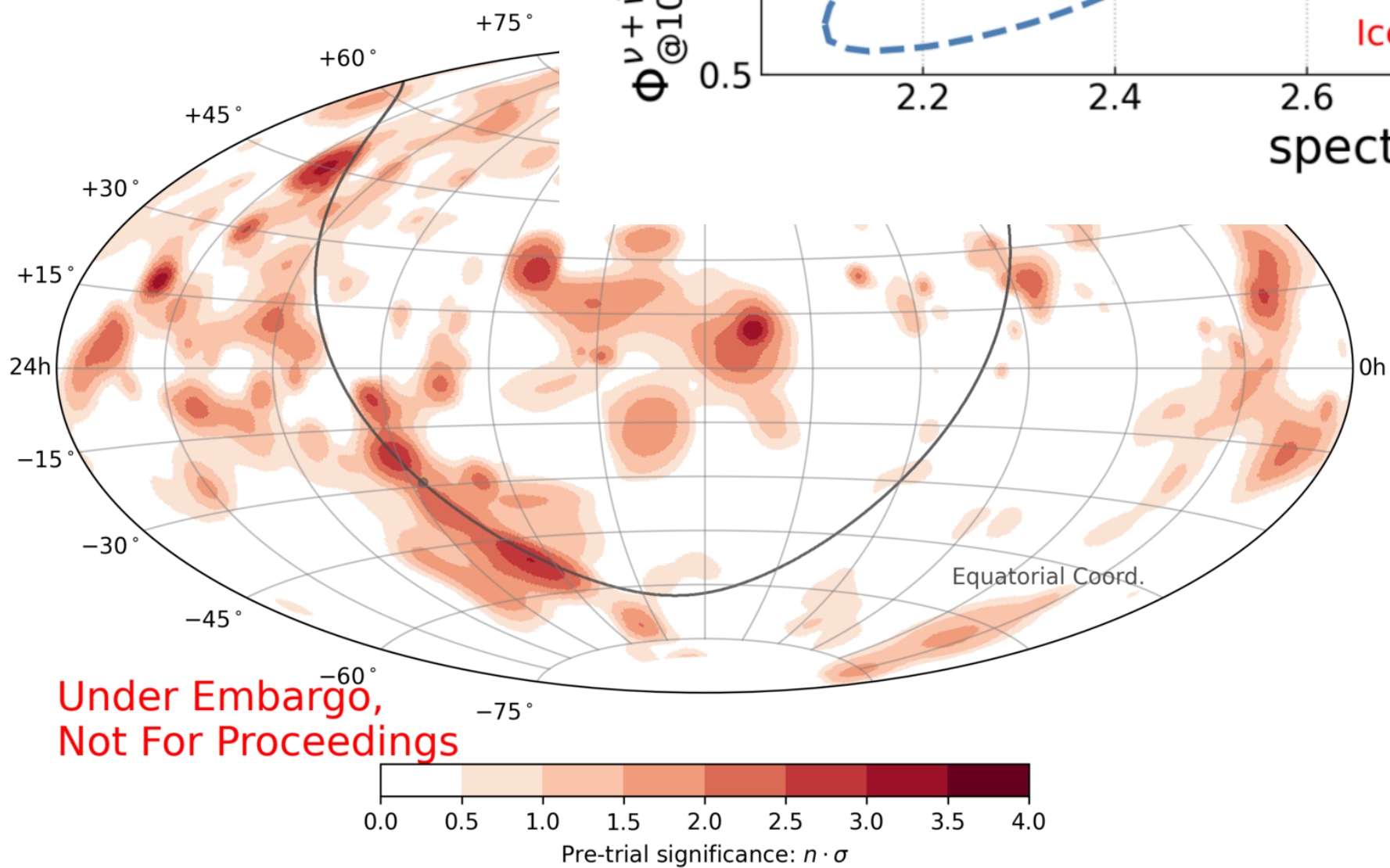
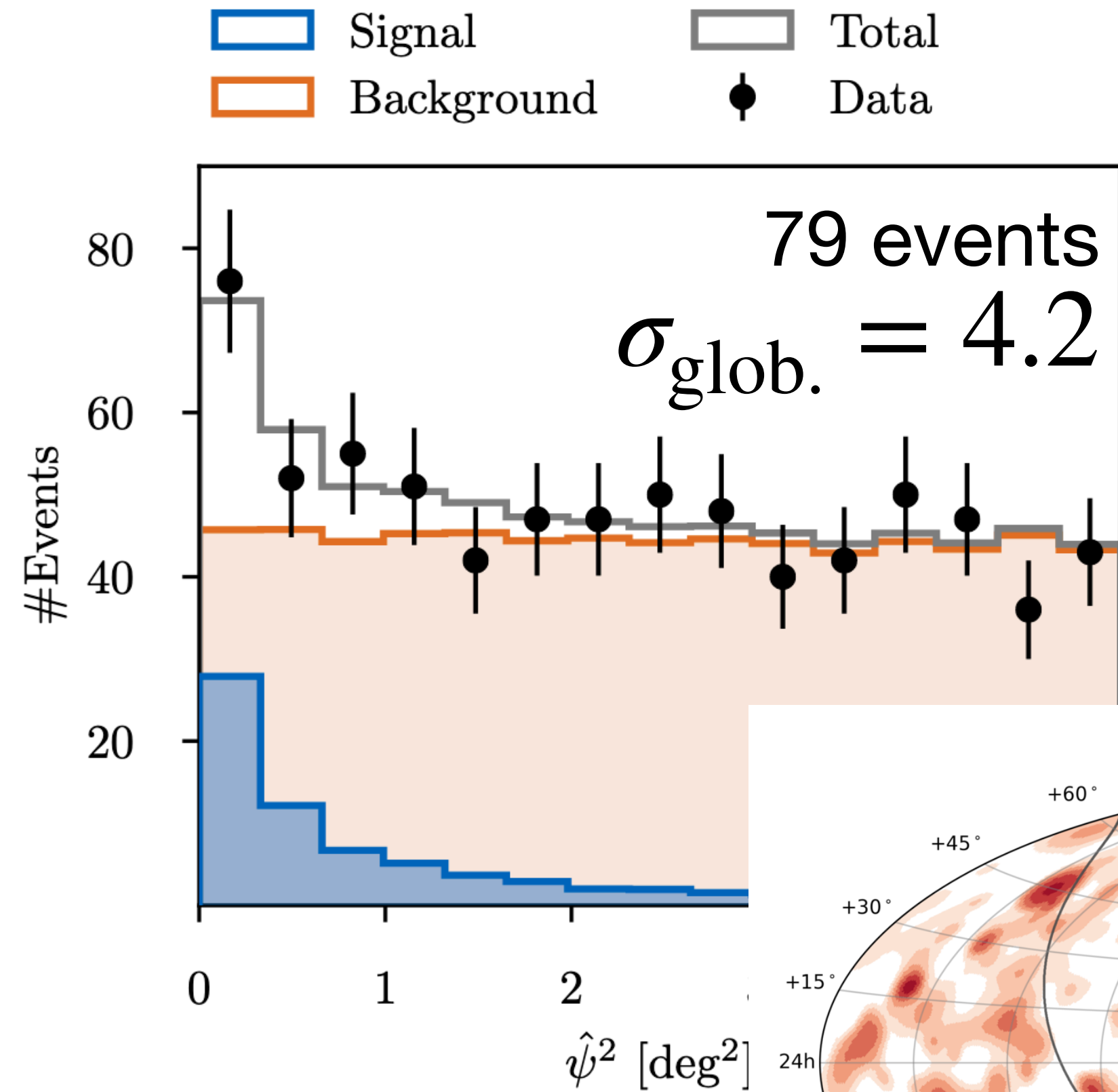

# New shapes

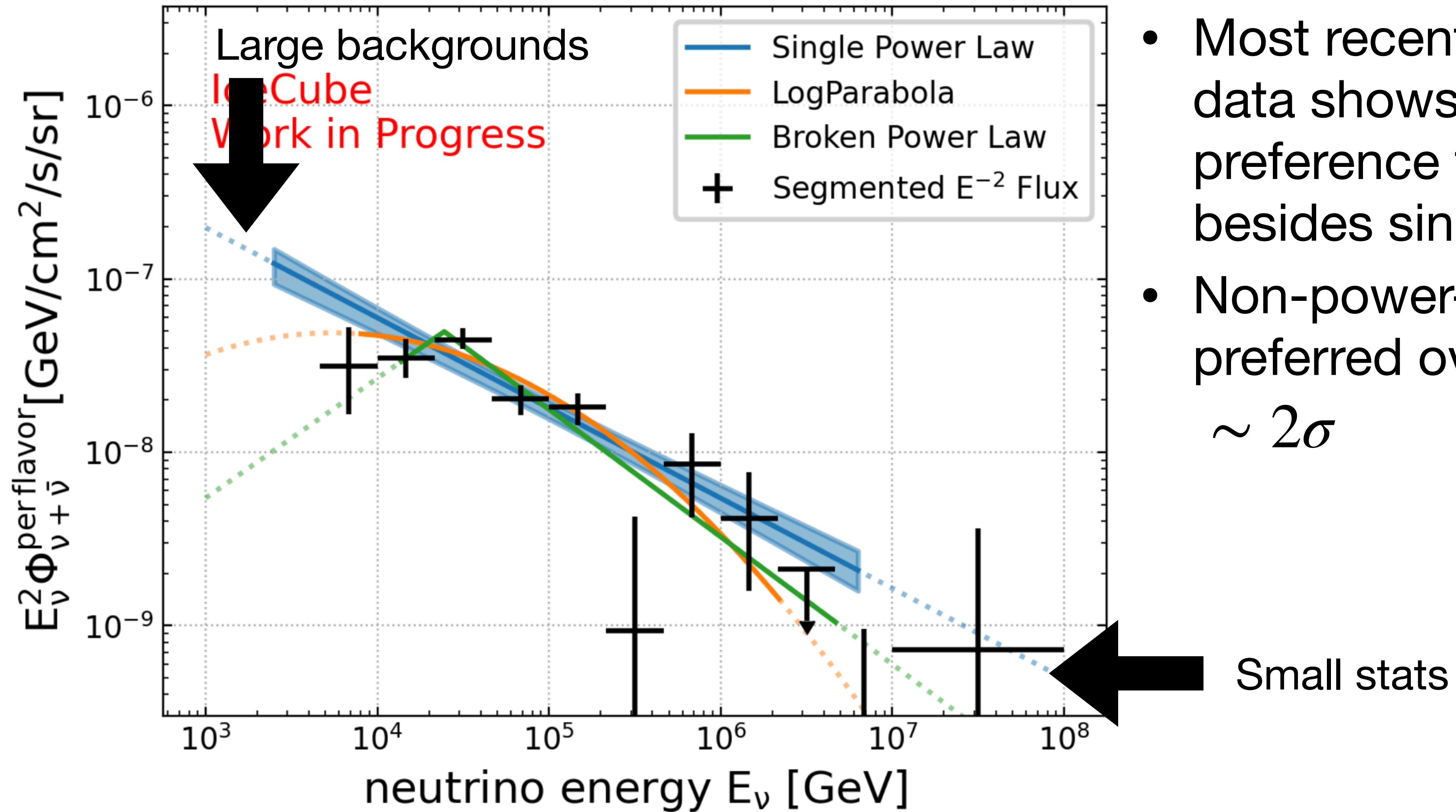

- Most recent global fit of the data shows a moderate preference flux models besides single power law
- Non-power-law spectra preferred over power law at  $\sim 2\sigma$

# Flavor Degeneracy

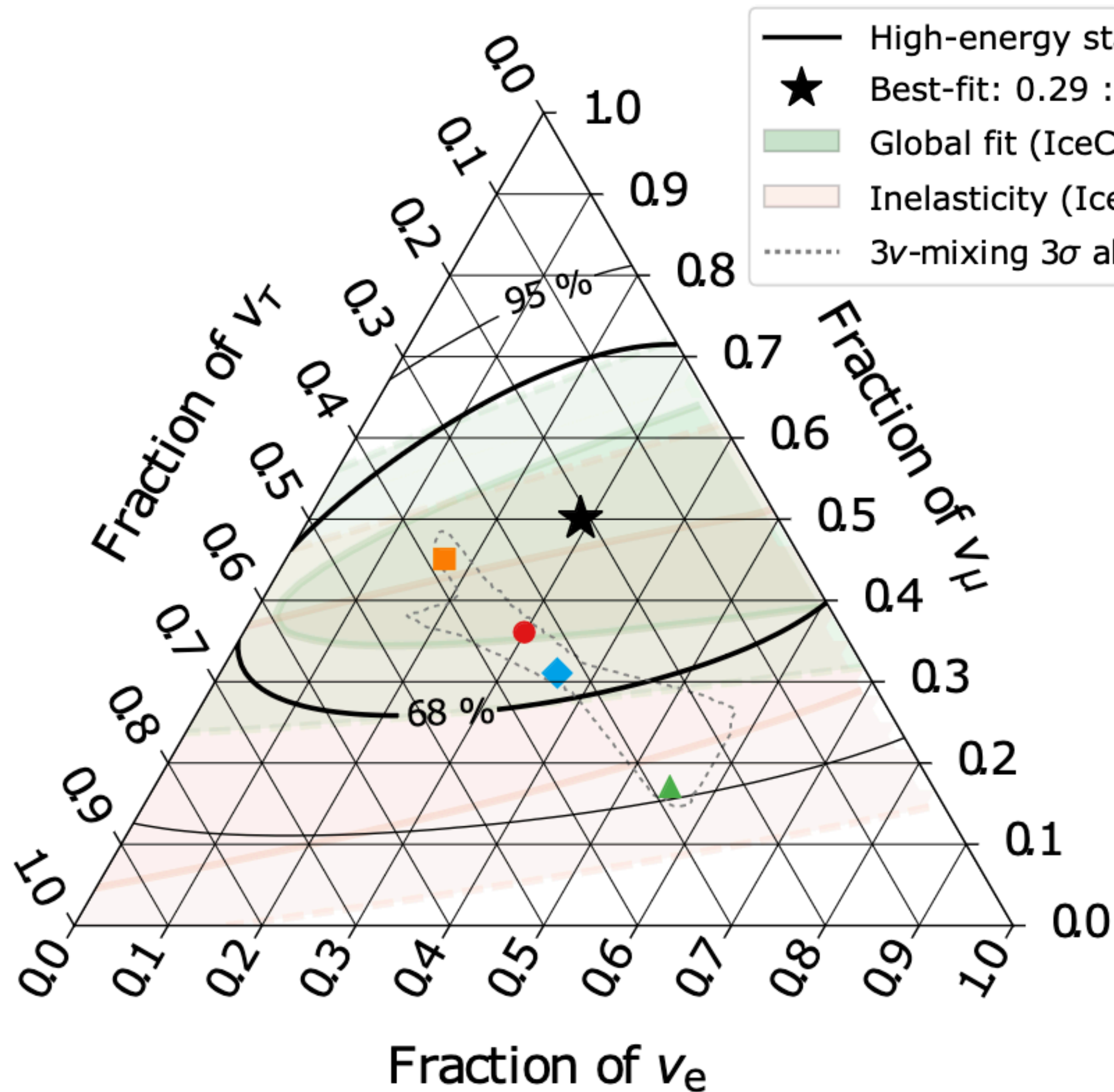

$\nu_e : \nu_\mu : \nu_\tau$  at source  $\rightarrow$  on Earth:

■	0:1:0 $\rightarrow$ 0.17 : 0.45 : 0.37
●	1:2:0 $\rightarrow$ 0.30 : 0.36 : 0.34
▲	1:0:0 $\rightarrow$ 0.55 : 0.17 : 0.28
◆	1:1:0 $\rightarrow$ 0.36 : 0.31 : 0.33

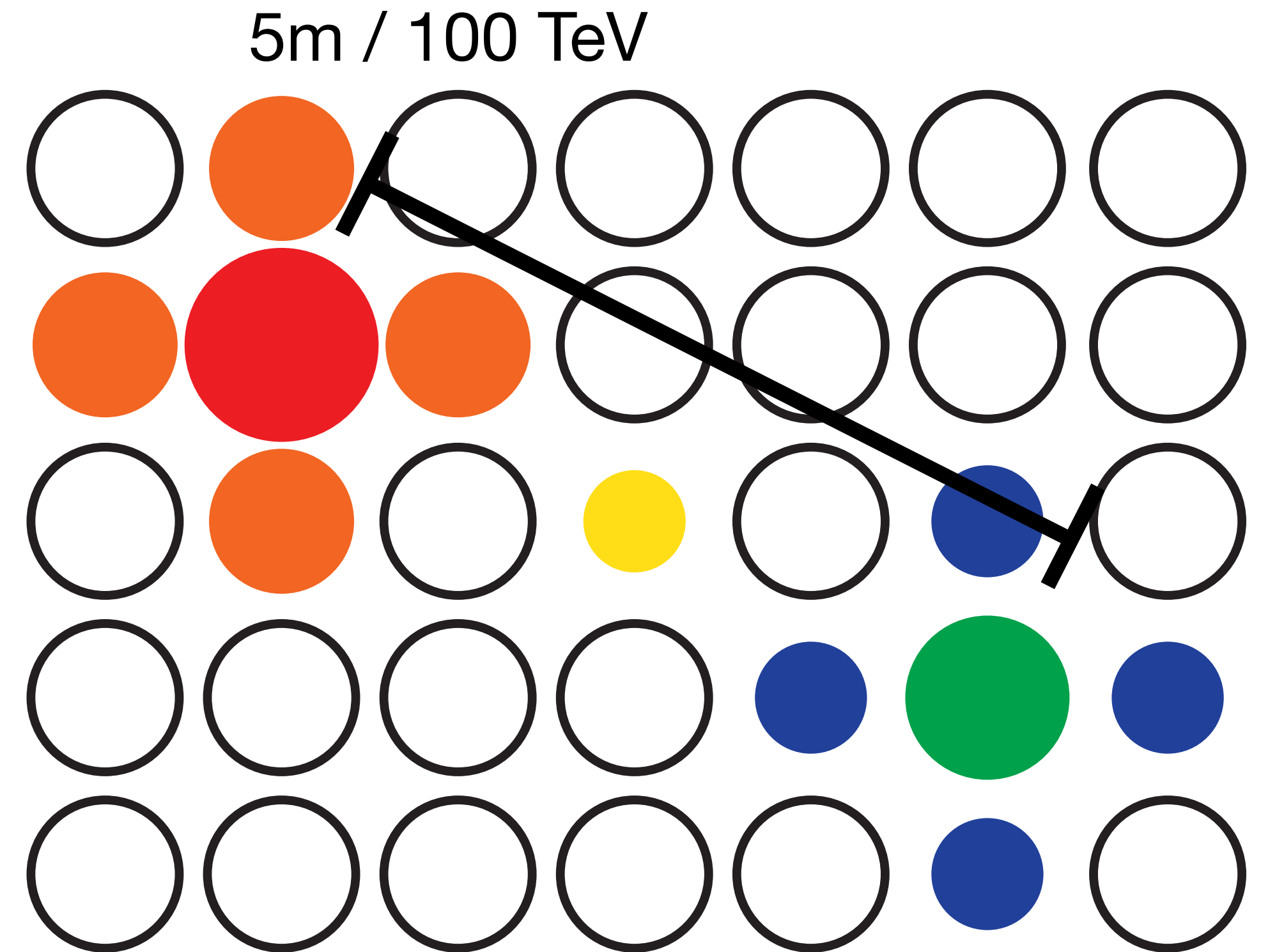

# Where Are the Rest of the Sources ?

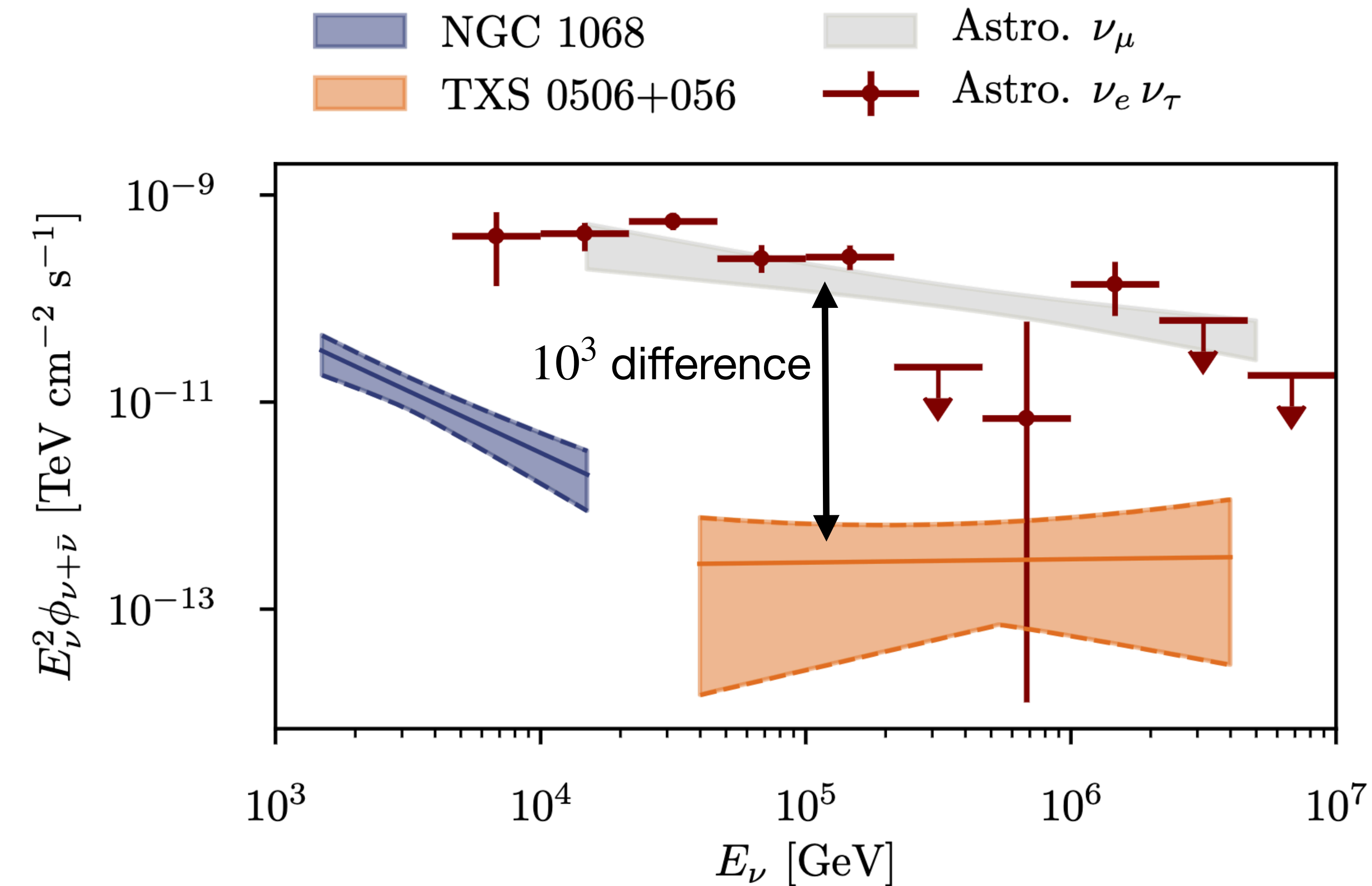

- IceCube has identified three point source candidates, two of which have enough event to fit a spectrum
- They can only make up a tiny fraction of the measured diffuse spectrum

# Trials and Tribulations

Test type	Pre-trial p-value ( $p_{local}$ )	Post-trial p-value ( $p_{global}$ )
Northern Hemisphere scan	$5.0 \times 10^{-8}$ ( $5.3 \sigma$ )	$2.2 \times 10^{-2}$ ( $2.0 \sigma$ )
List of candidate sources, single test	$1.0 \times 10^{-7}$ ( $5.2 \sigma$ )	$1.1 \times 10^{-5}$ ( $4.2 \sigma$ )
List of candidate sources, binomial test	$4.6 \times 10^{-6}$ ( $4.4 \sigma$ )	$3.4 \times 10^{-4}$ ( $3.4 \sigma$ )

$\sim 445,000$  trials  
 $\implies 19.8 \frac{\text{trials}}{\sigma^2}$

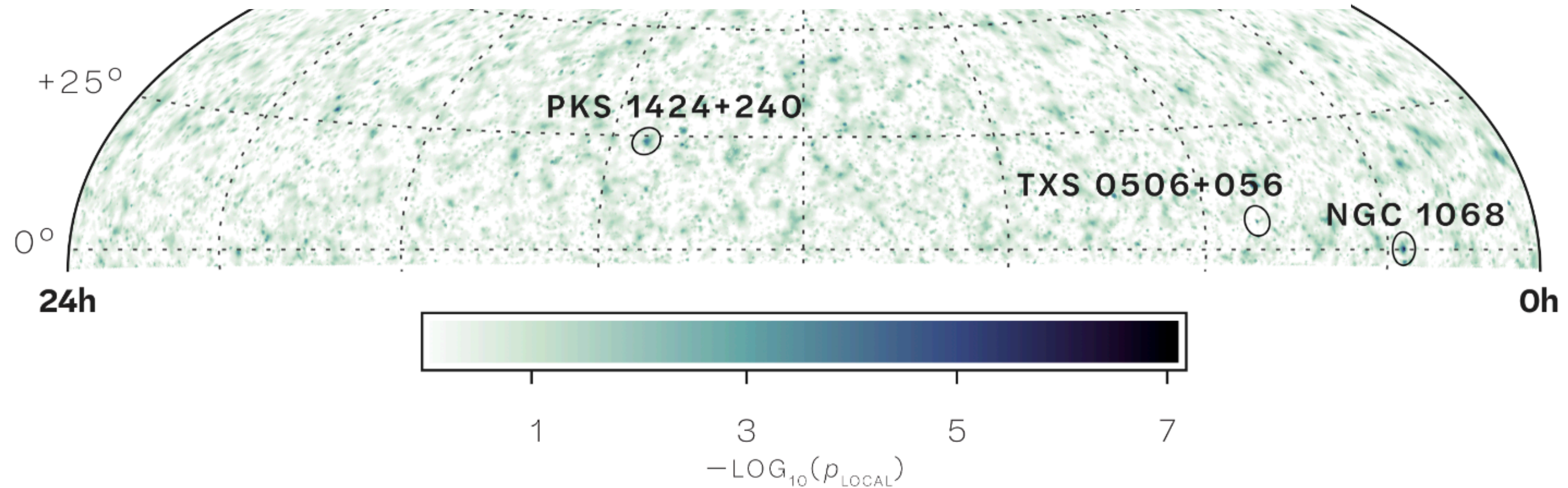

# We're Not Short on Ideas

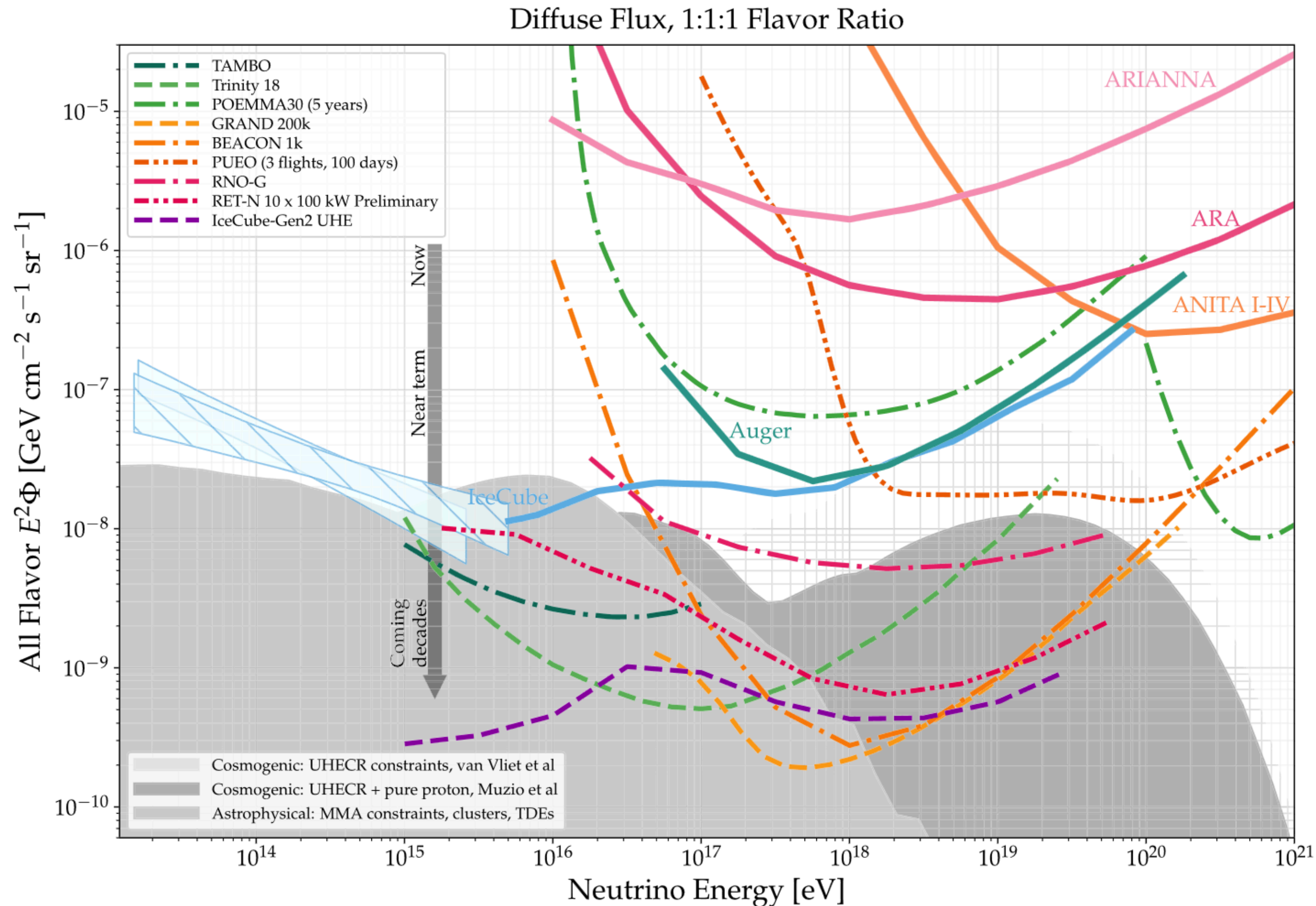

- Many next generation detectors will target 100 TeV to 10 EeV neutrinos
- New technologies and detector principles will enable this push

# We're Not Short on Ideas

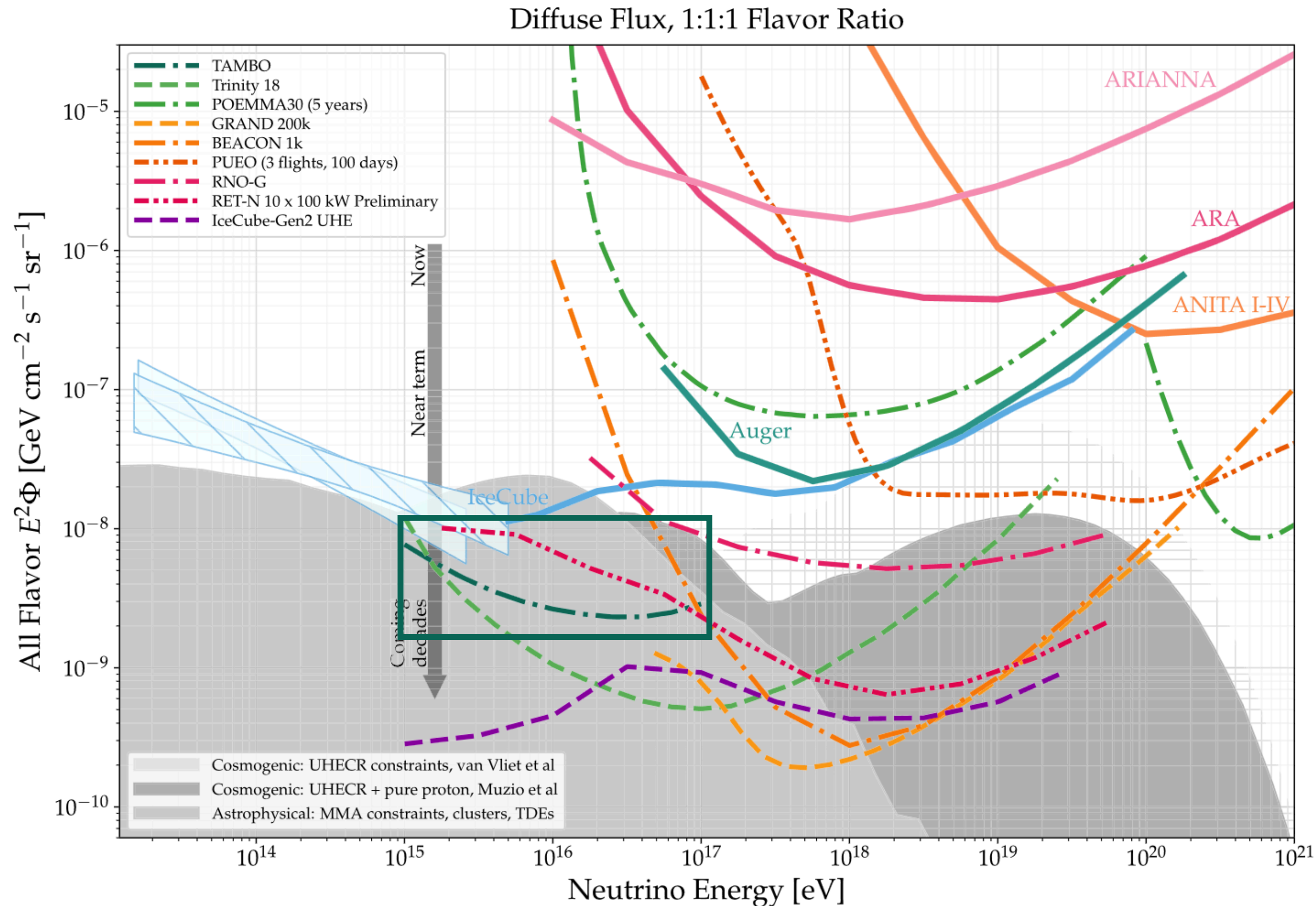

- Many next generation detectors will target 100 TeV to 10 EeV neutrinos
- New technologies and detector principles will enable this push

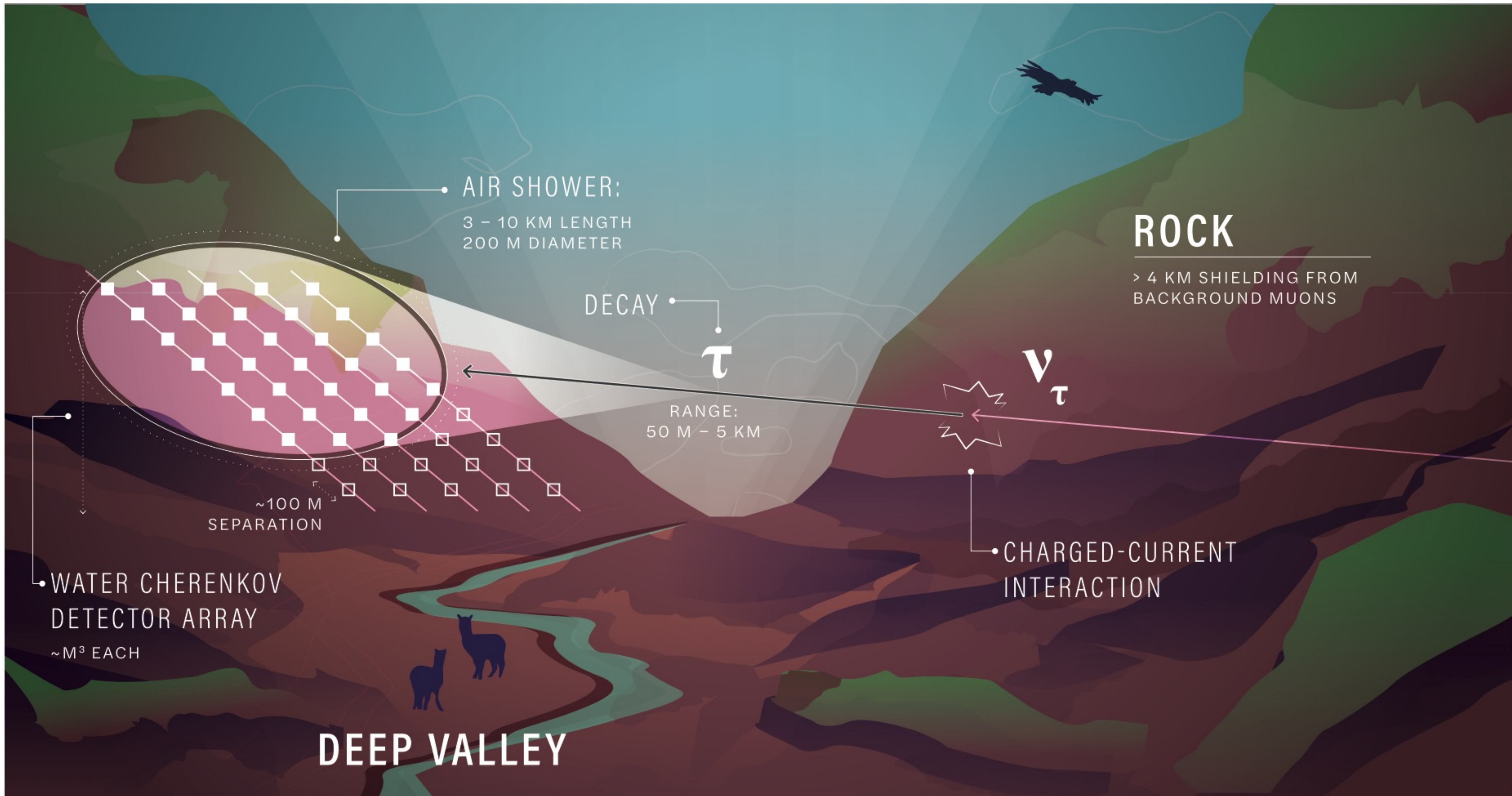

TAU AIR-SHOWER MOUNTAIN-BASED OBSERVATORY (TAMBO) • COLCA VALLEY, PERU

# Passing the Energy Baton

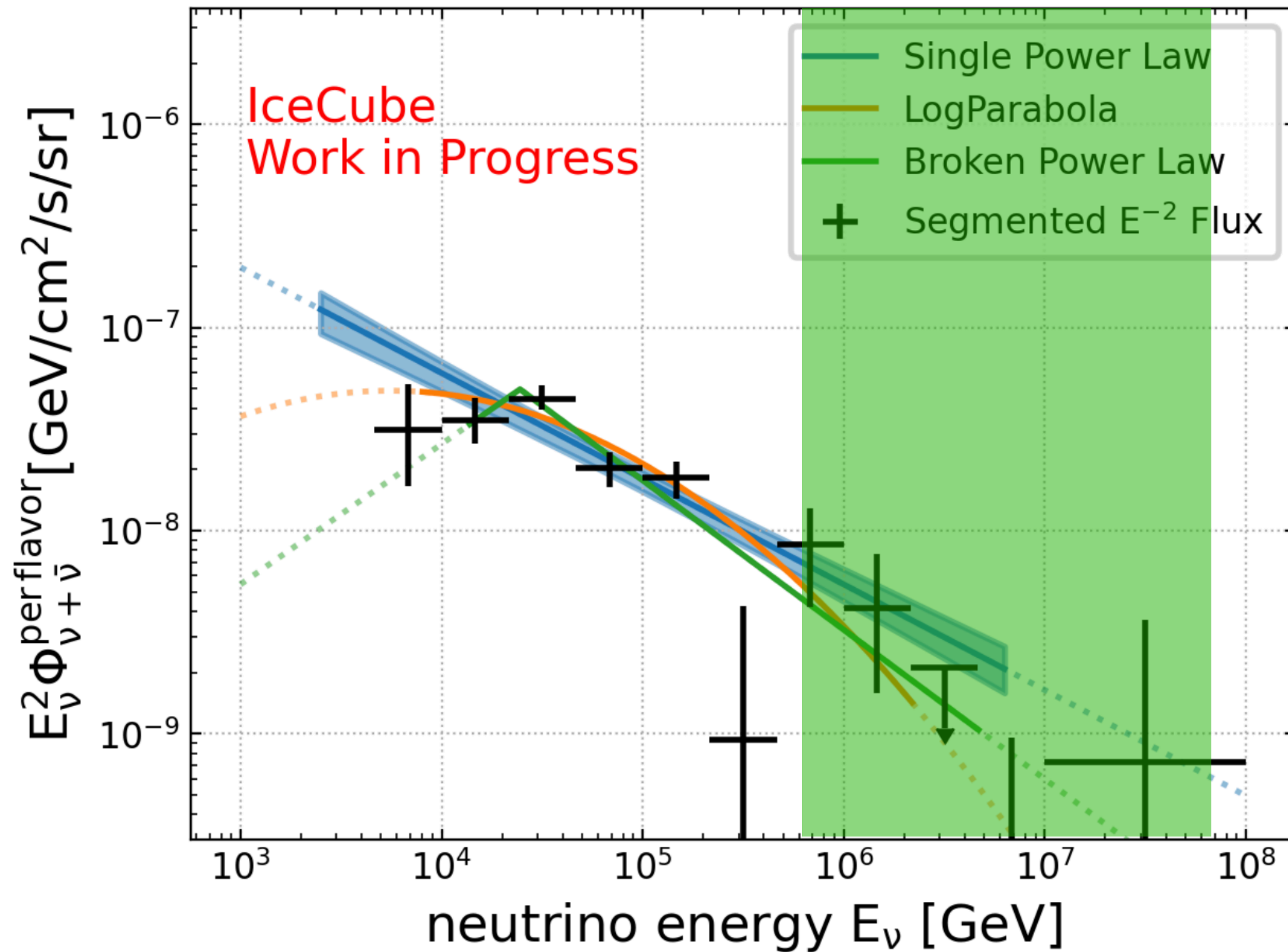

TAMBO regime

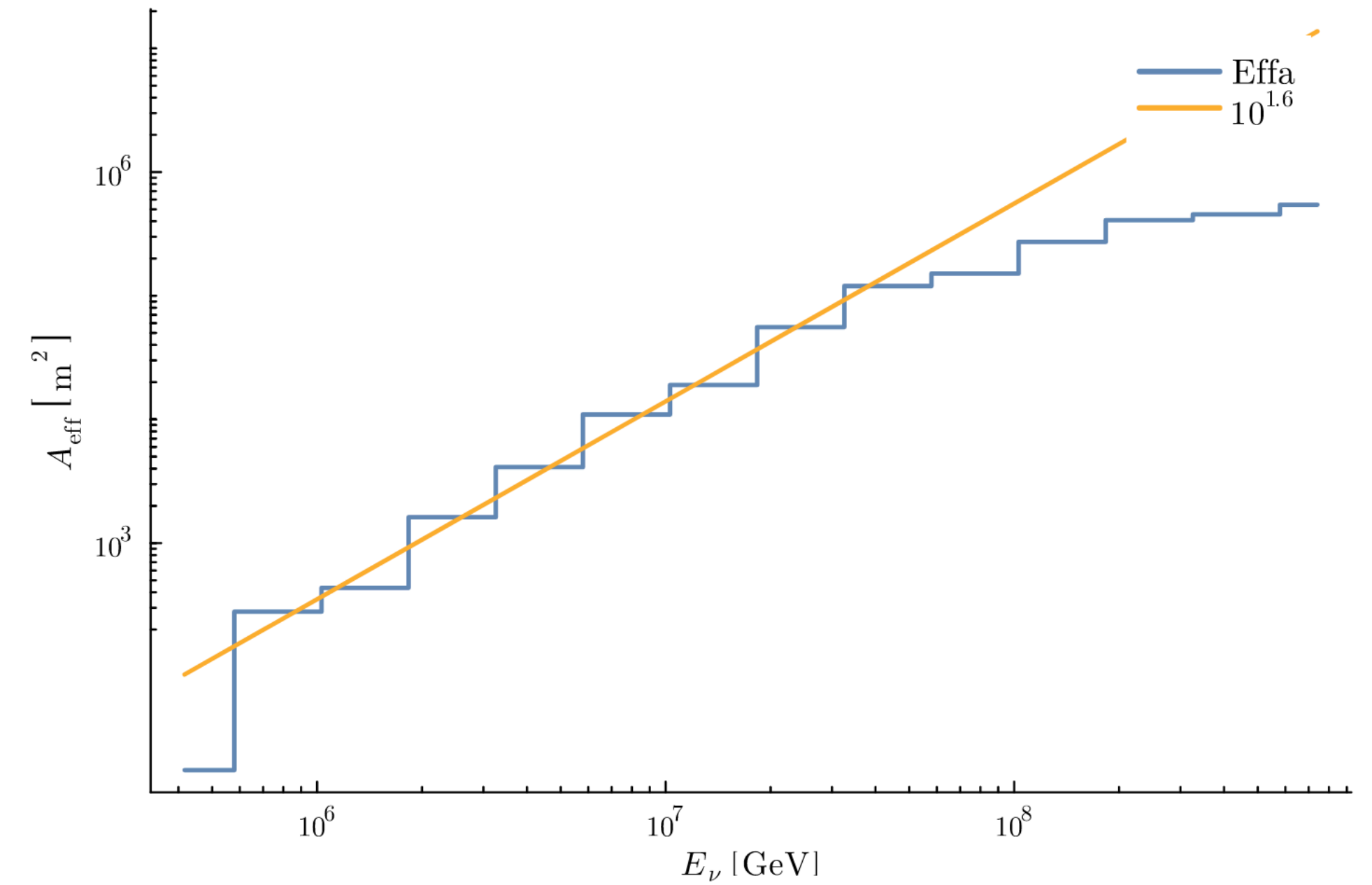

TAMBO becomes sensitive right towards the end of IceCube's sensitivity

# A $\nu_\tau$ Sieve



# A $\nu_\tau$ Sieve

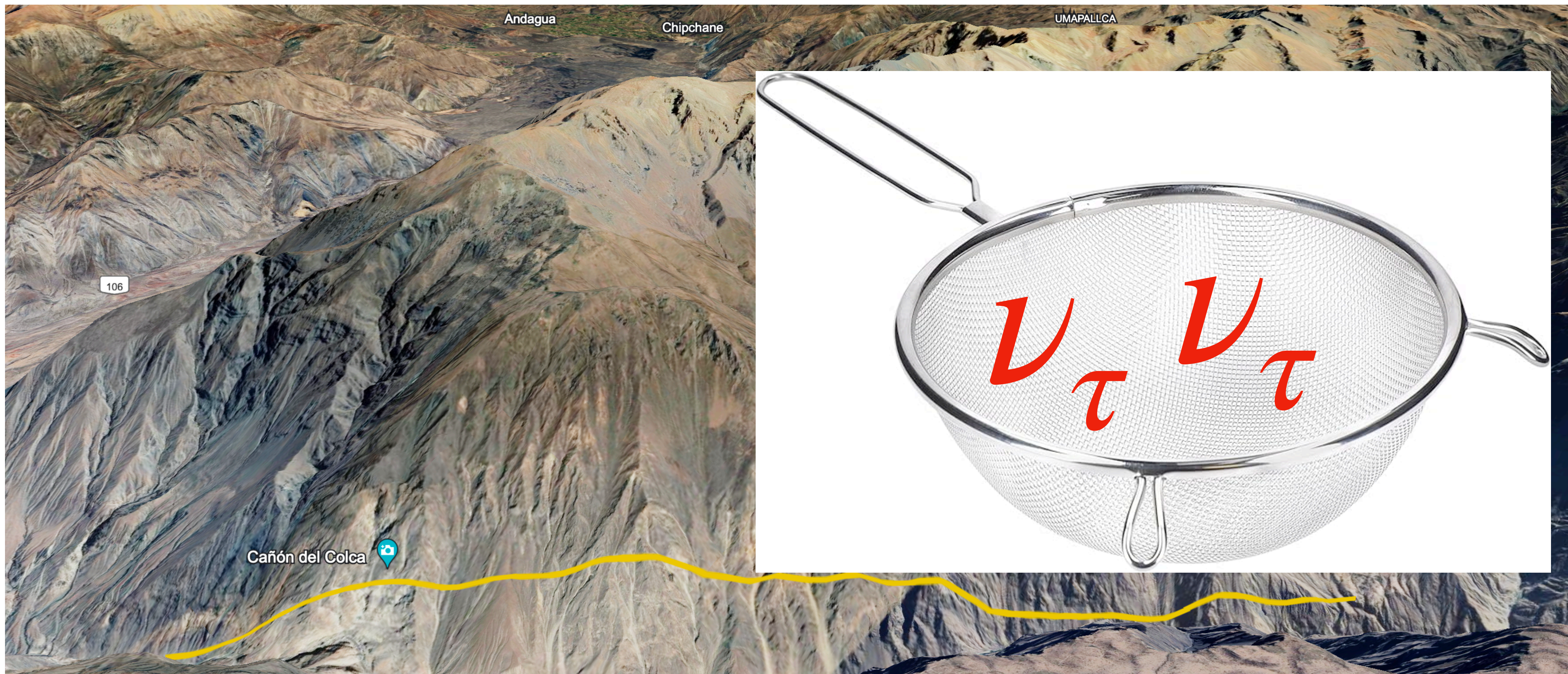

# A $\nu_\tau$ Sieve

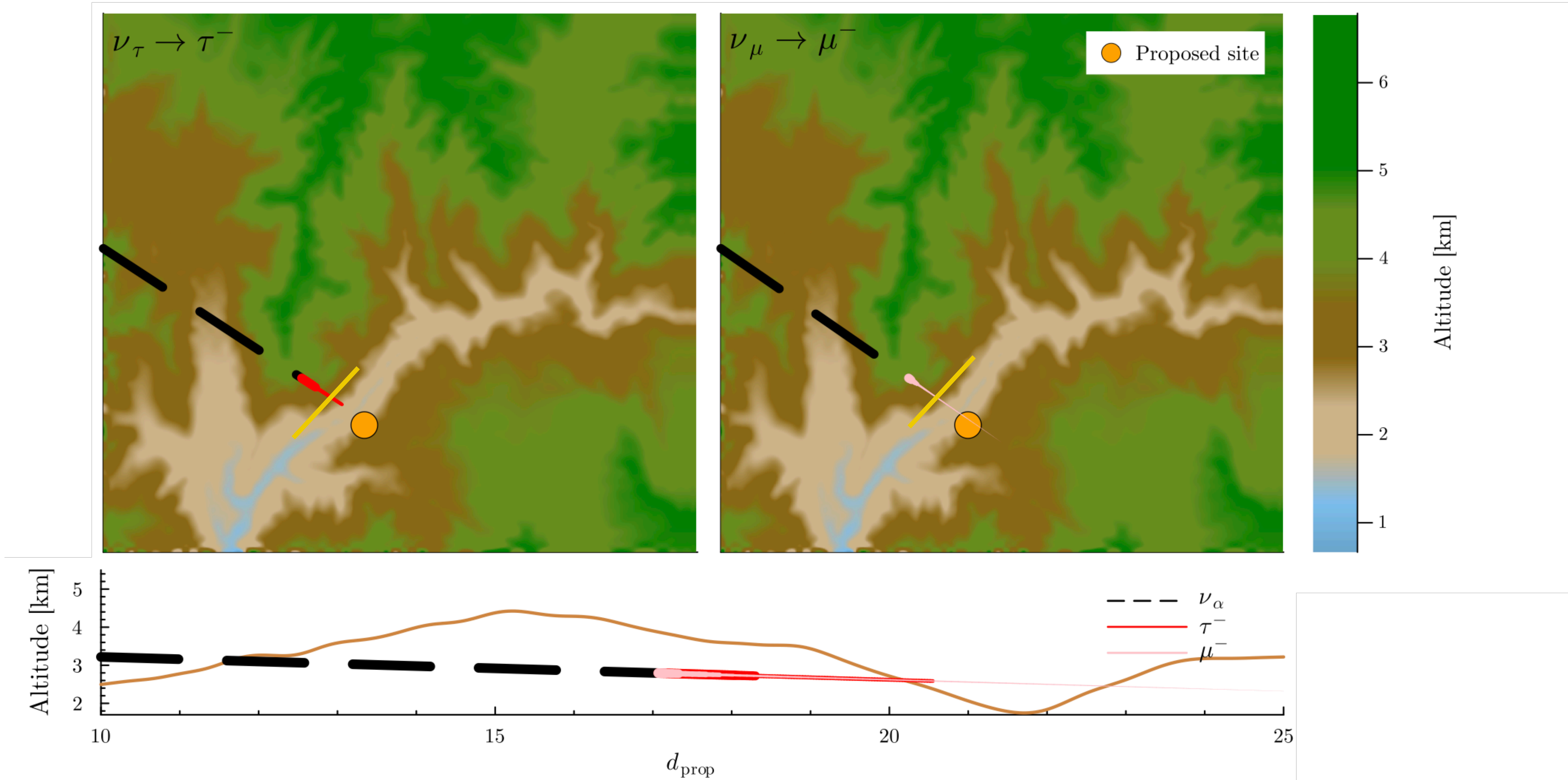

# Reminder: Power-Law Sources

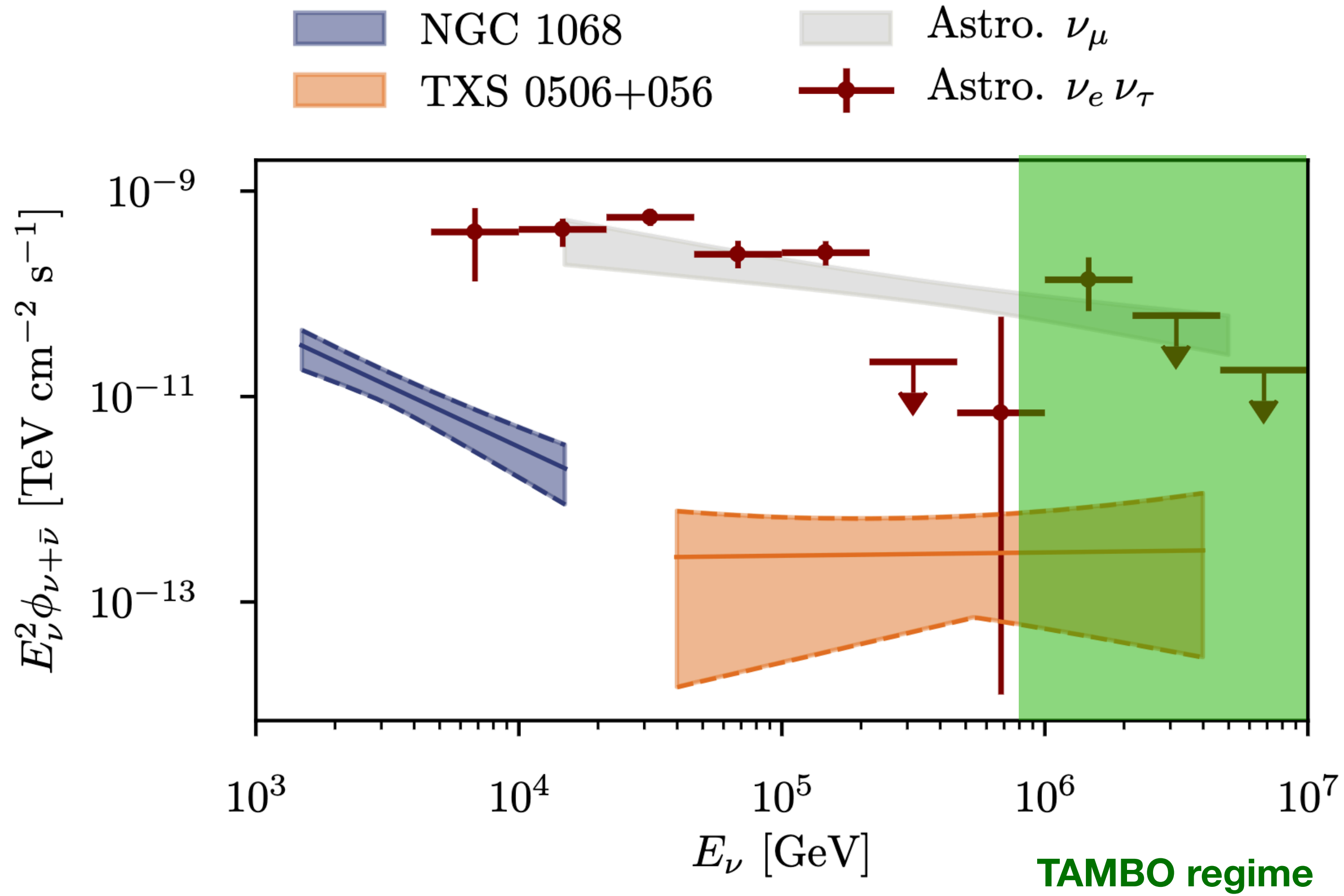

# Reminder: Power-Law Sources

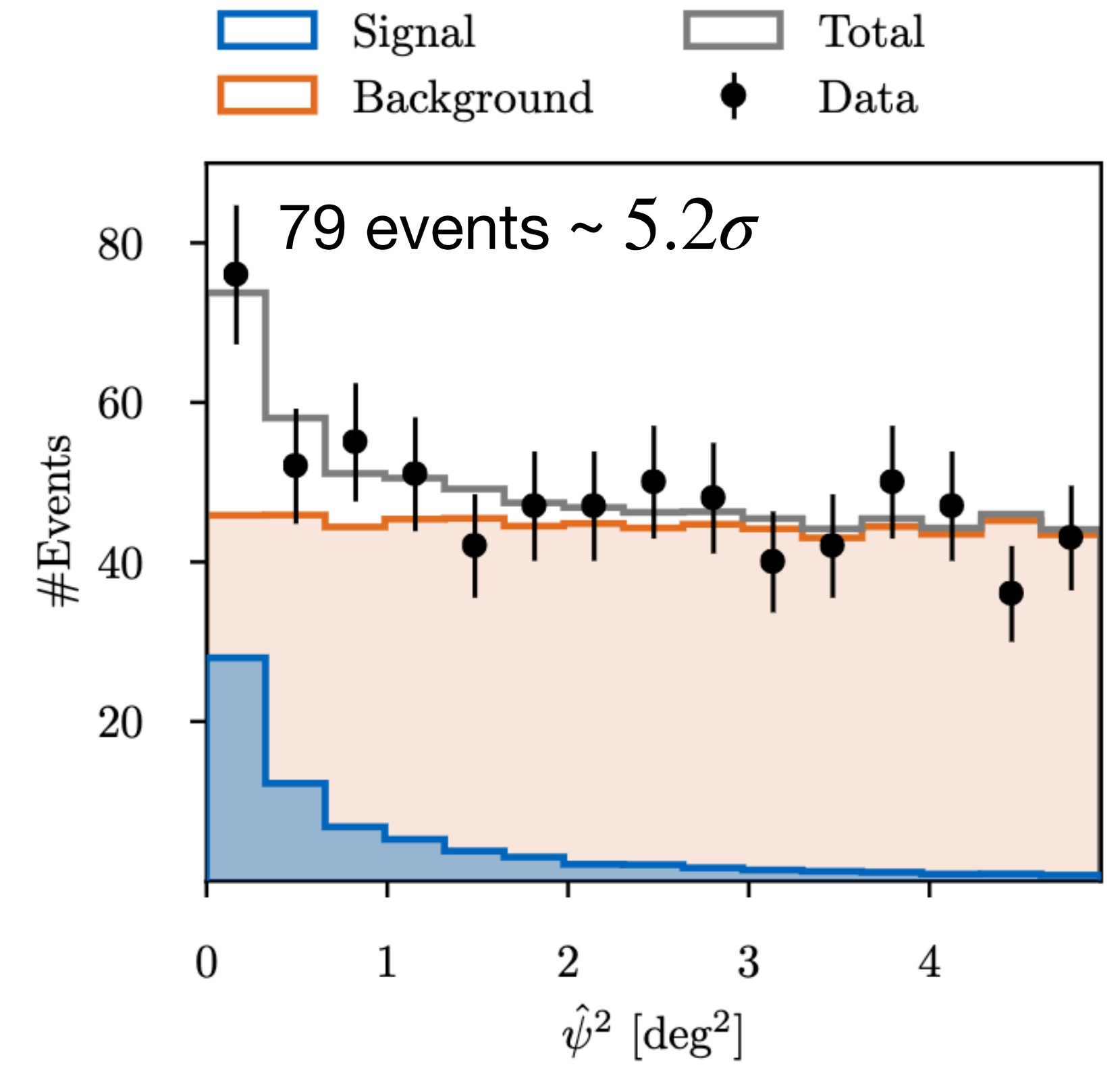
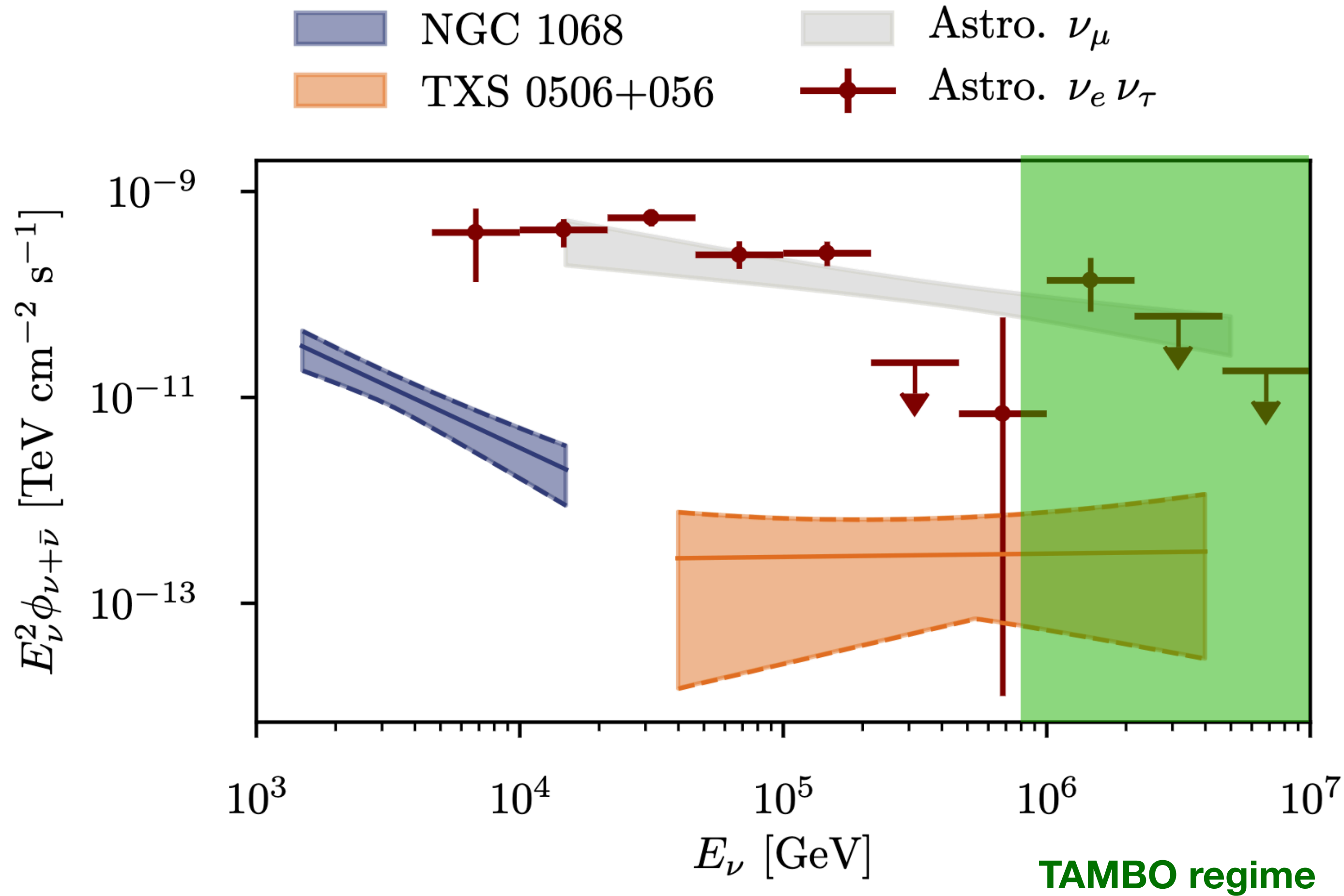

# An Initial Estimation

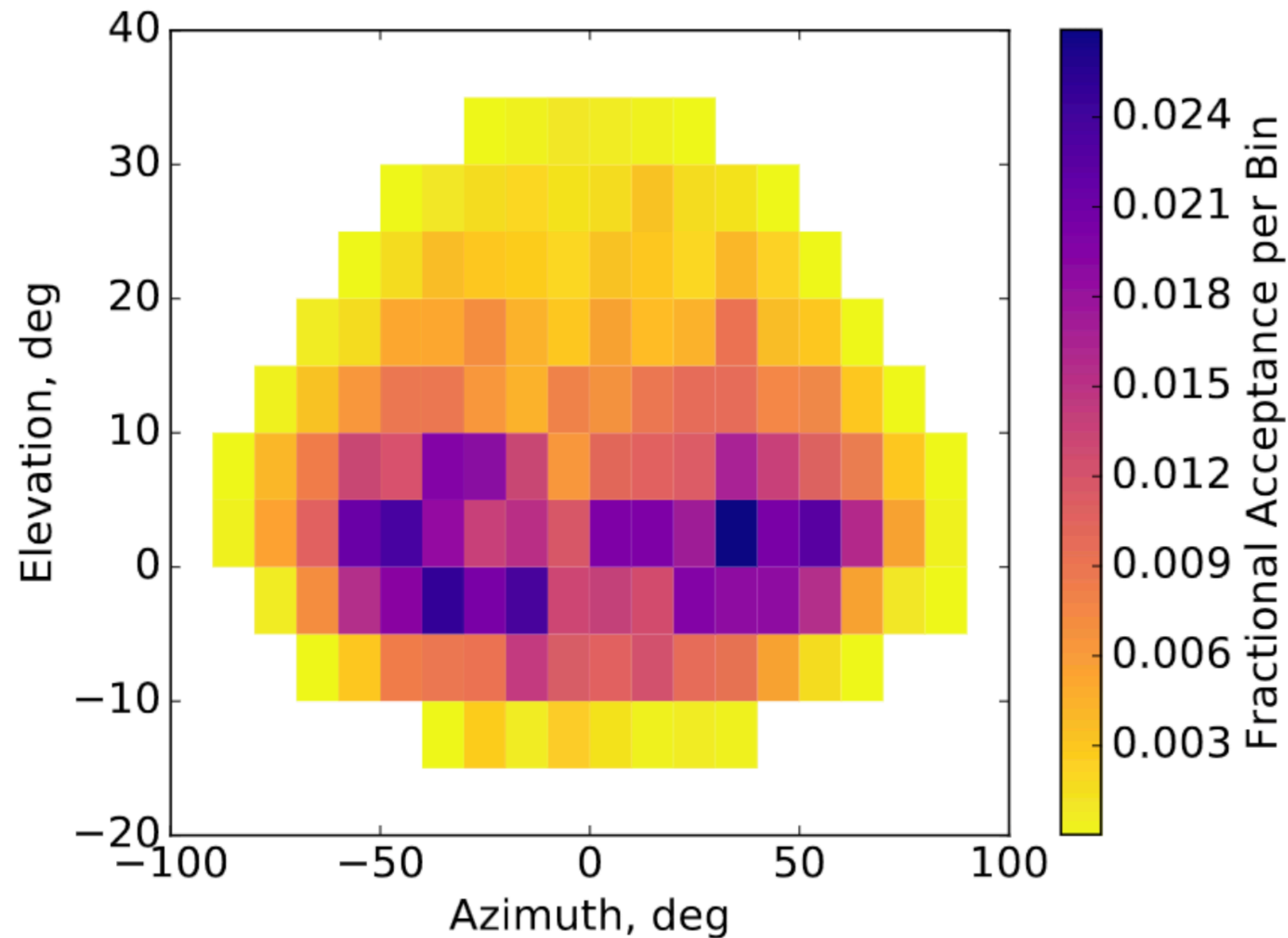

- 22\_000 Cherenkov water tanks with 150m interdetector spacing
- Triggering procedure to reject major background of coincident atmospheric muons

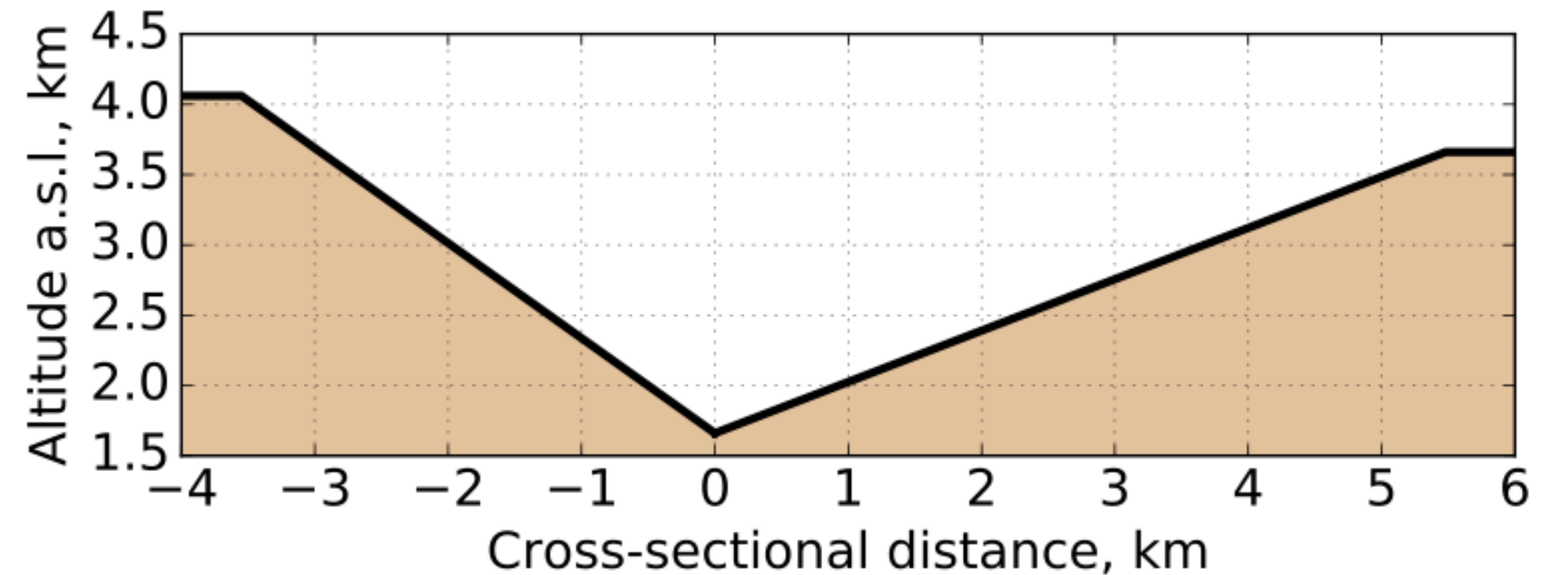

# An Initial Estimation

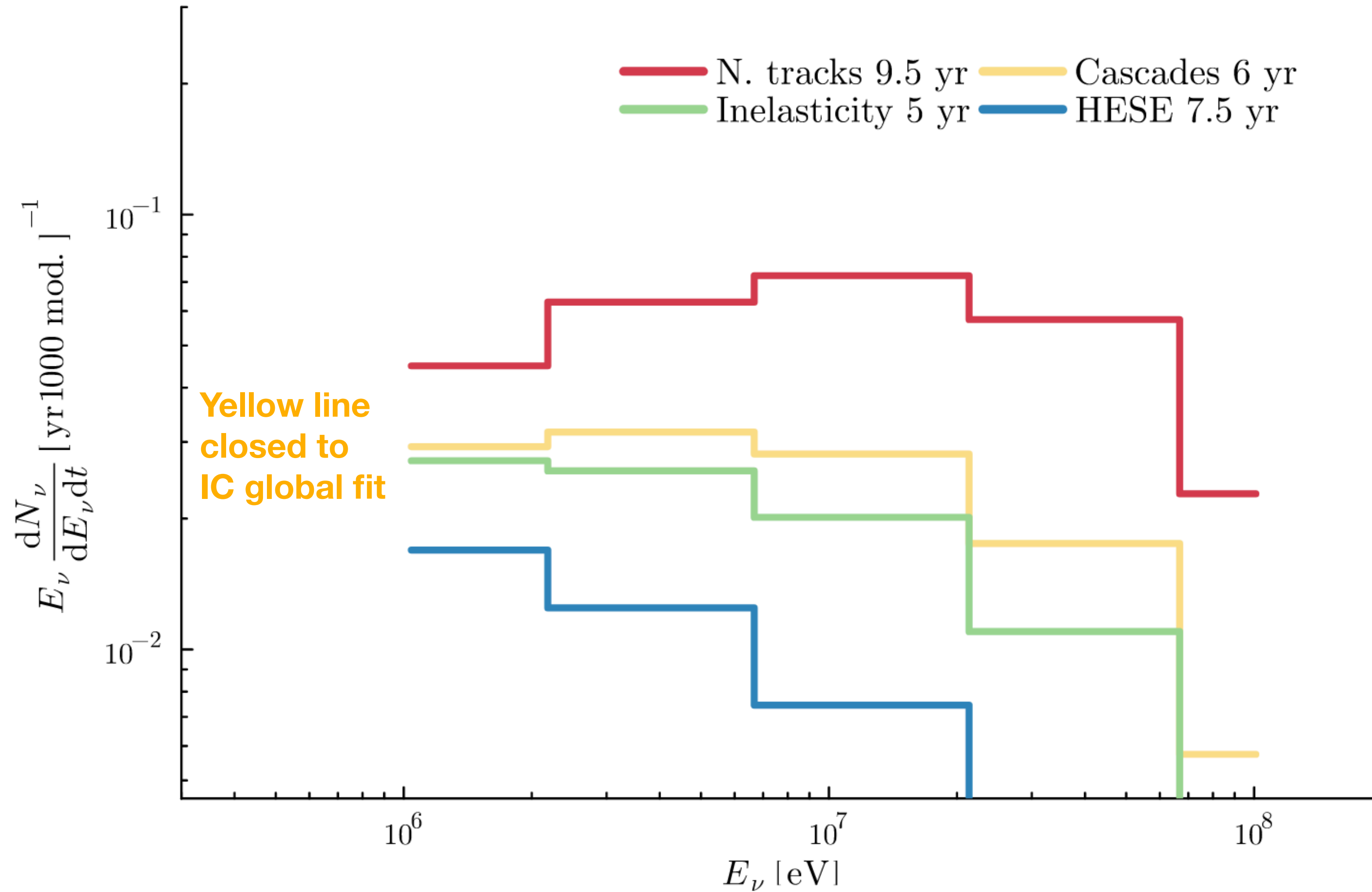

Conservative estimates and analytical approximations showed that we should expect between **0.27 and 0.04 detections per year per 1,000 detectors**

# An Initial Estimation

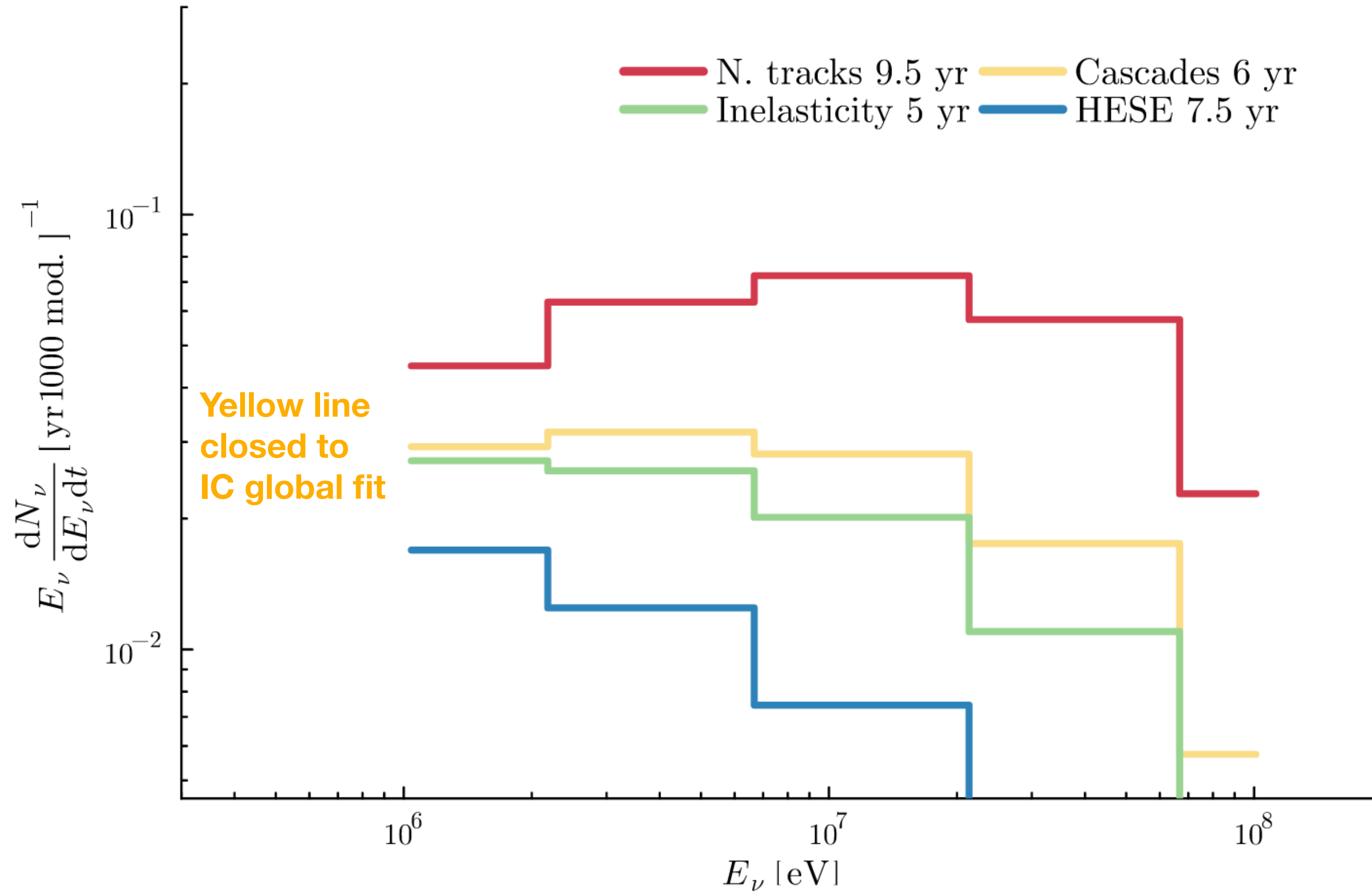

Conservative estimates and analytical approximations showed that we should expect between **0.27 and 0.04 detections per year per 1,000 detectors**



Higher events rates incoming

# Site Selection Trip



- A few of us from Harvard went to the Colca Valley to look at sites and assess infrastructure
- The planned site is very far out, but there are less remote places that are viable for a test array

# Potential Test and Main Array Location



# Main Array Candidate Site

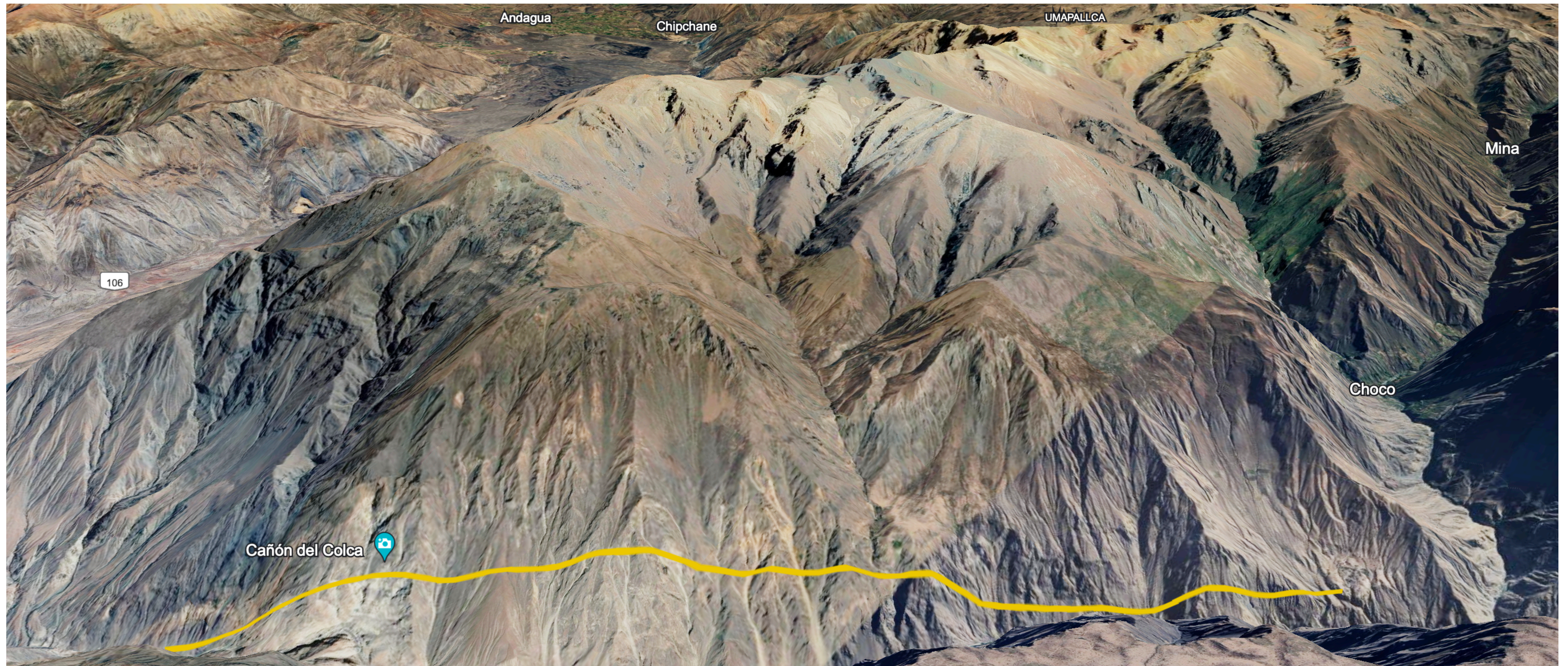

# Hardware Studies

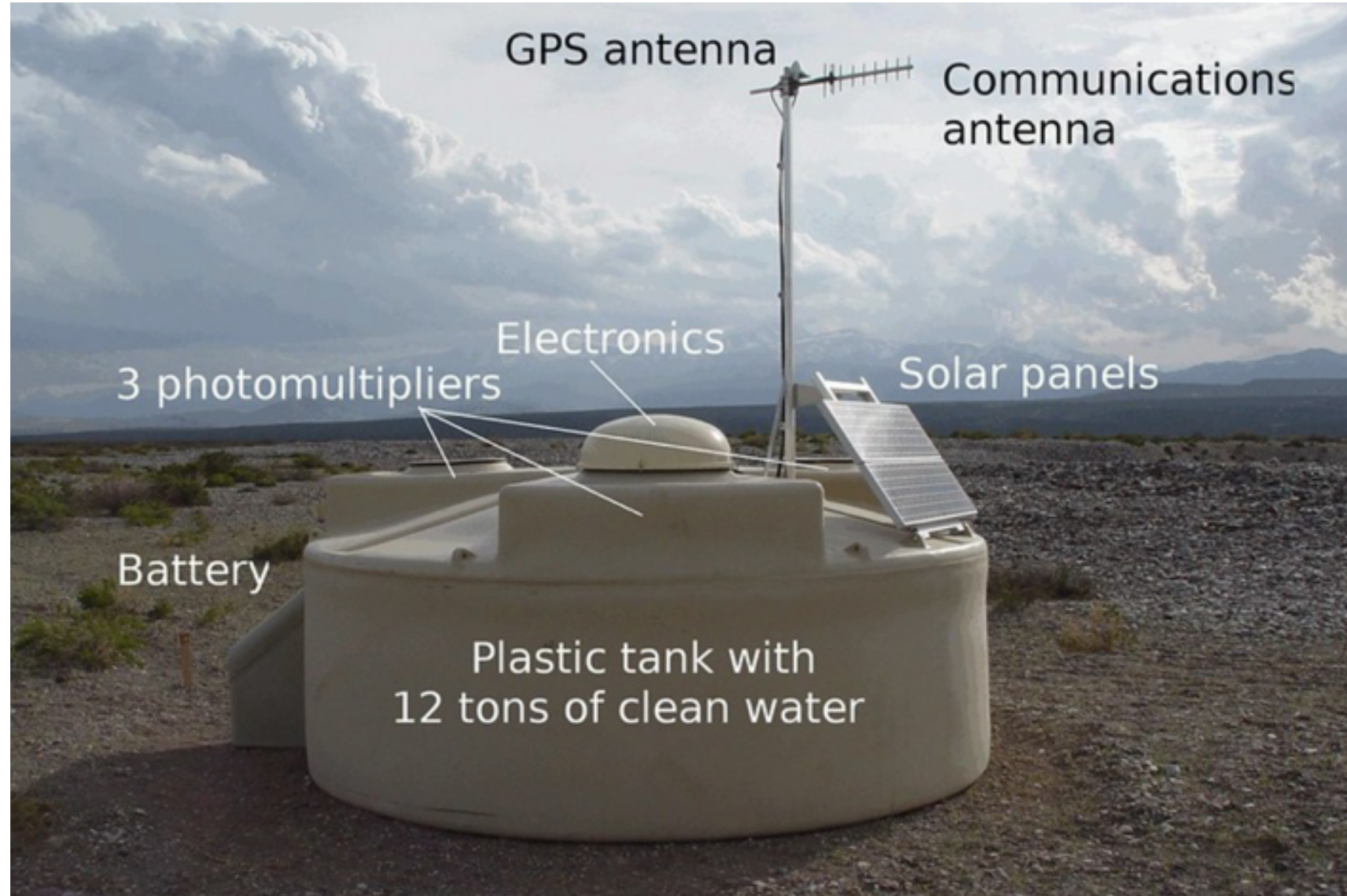

[Pierre Auger Collaboration, ICRC\(2021\)](#)

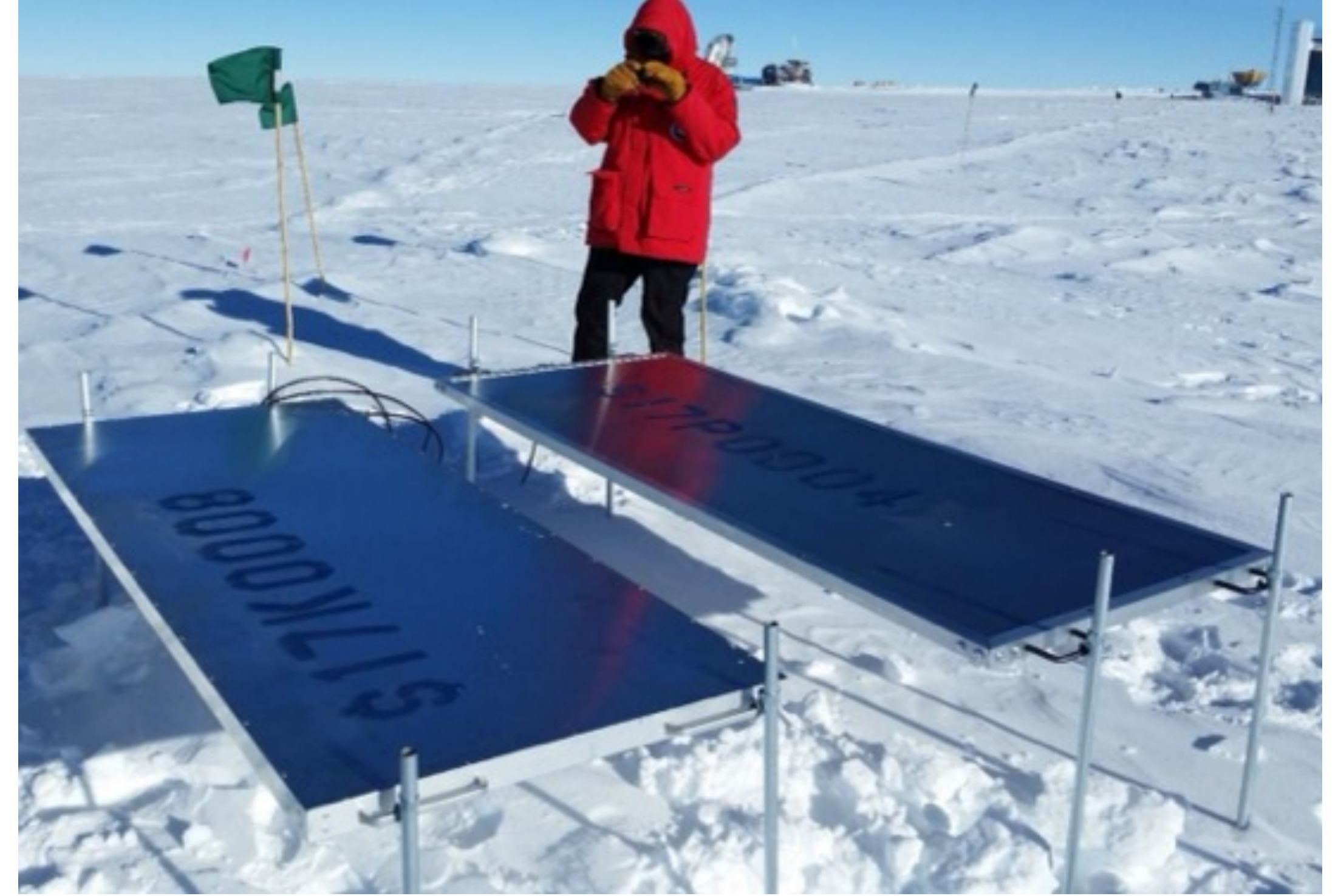

[IceCube Collaboration, EPJ Web Conf. \*\*210\*\* \(2019\)](#)

- Observatory is an array of thousands of individual detectors
- Two designs under consideration:
  - Water Cherenkov tanks → very well understood but heavy and expensive
  - Plastic scintillator panels → less well understood but 20x lighter and 2x cheaper

# First Light from Cosmic Rays

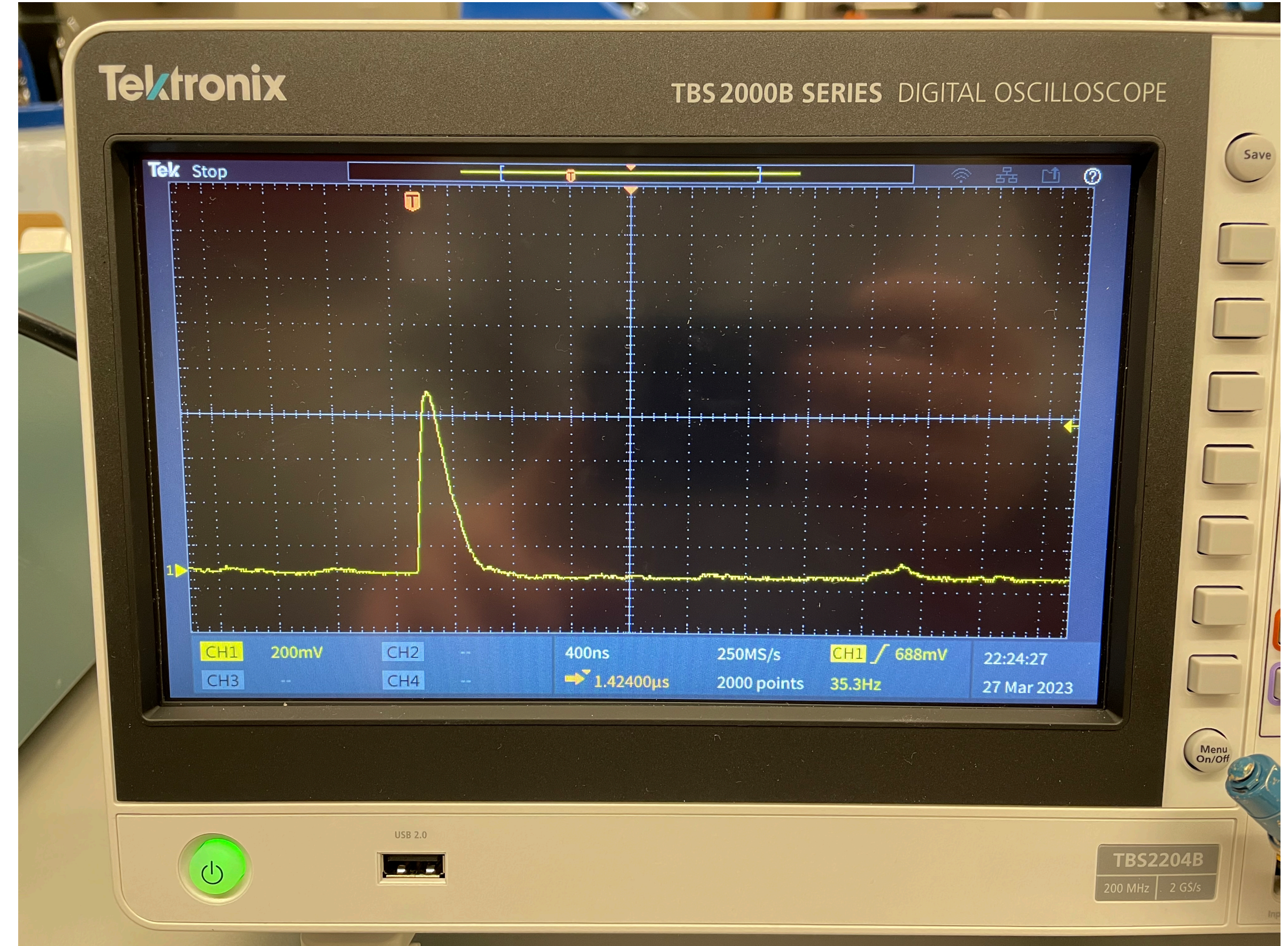
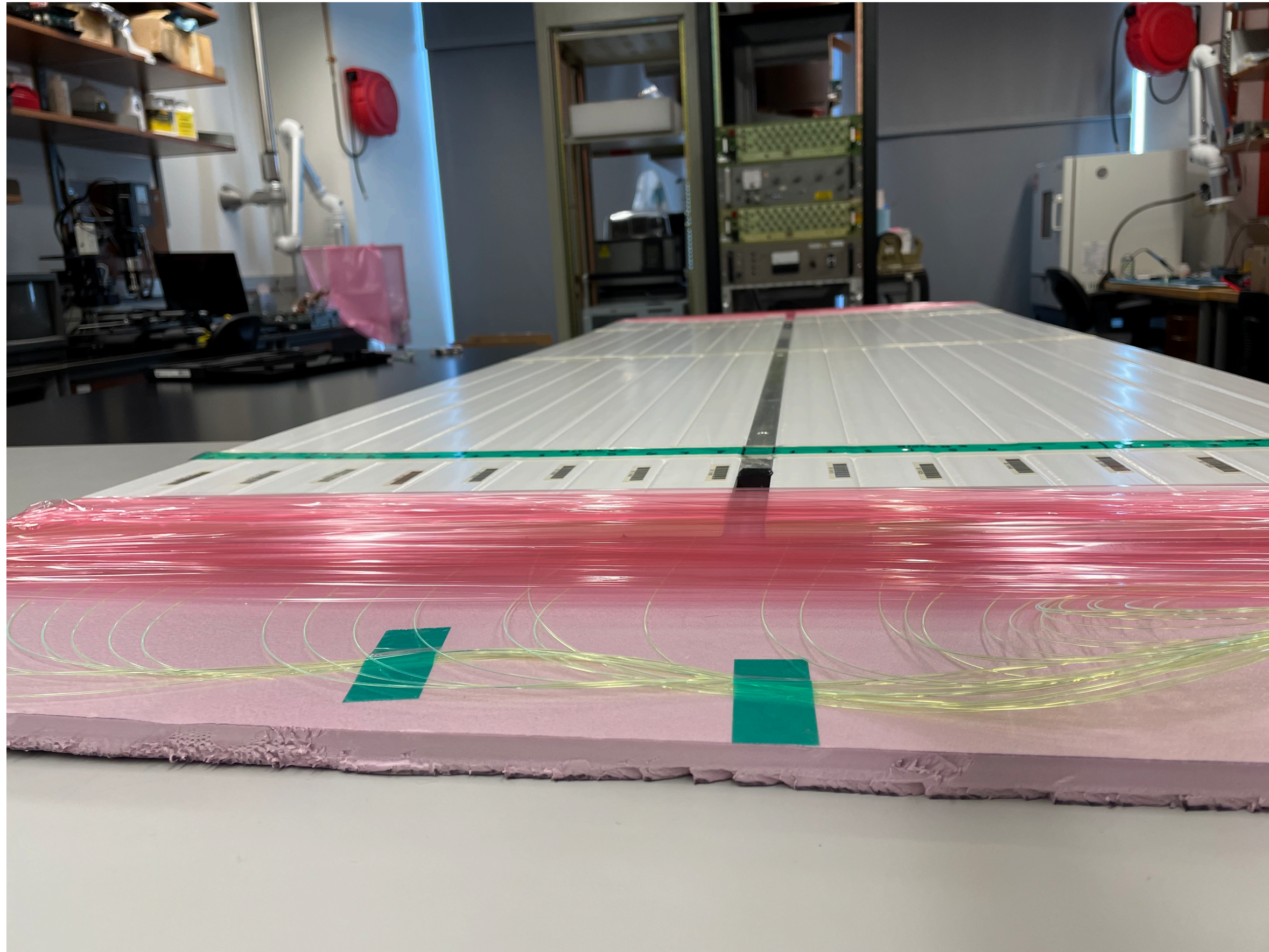

- First light from scintillator panels at Harvard
- Enough material to build 10 panels in total, which we expect to have by the end of the year

# A First Proof of Concept

- A small, three station deployment in Lima will allow us to test:
  1. Inter-module communication
  2. Synchronisation protocol
  3. Data acquisition and management
- It *may* be possible to identify air showers with this set up

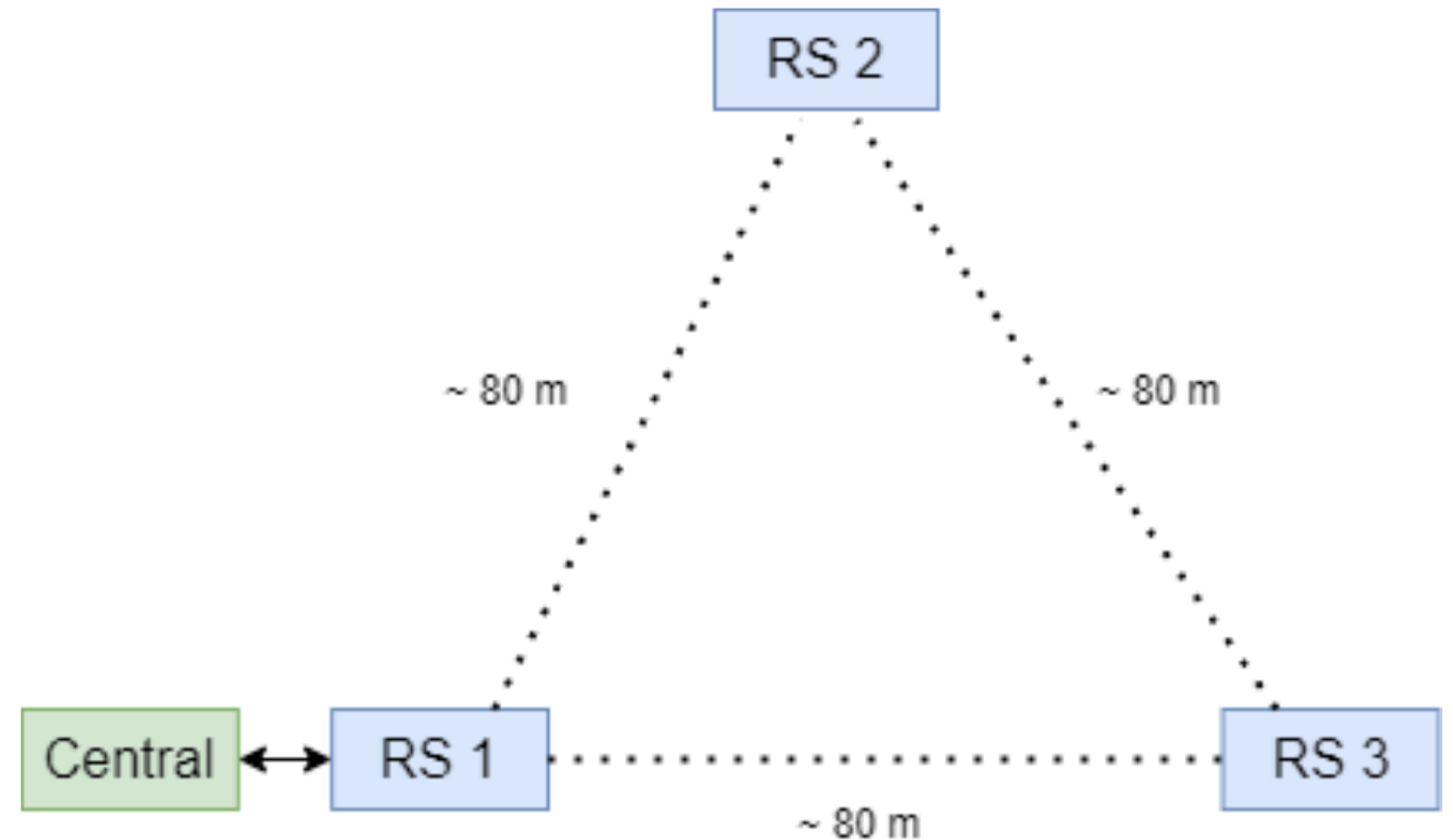

# Towards a Full Monte Carlo

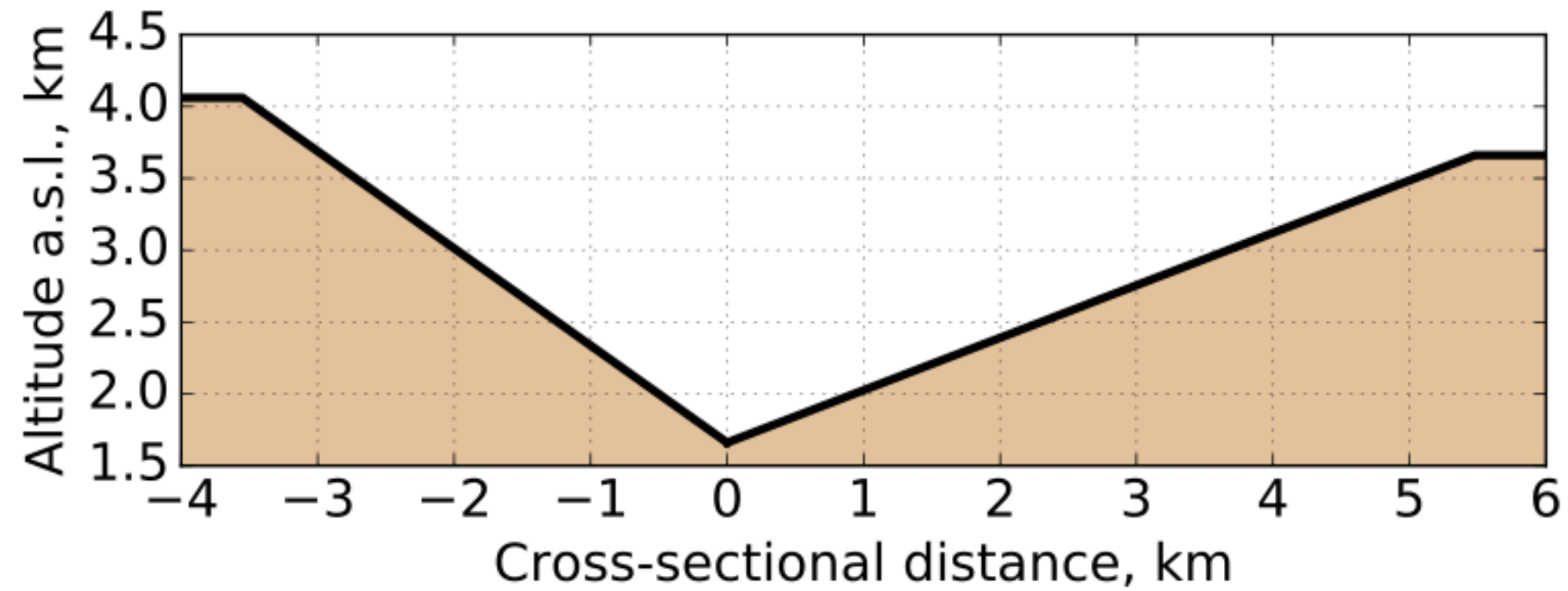

- Simplified geometry
- No treatment of  $\tau^\pm$  energy losses
- Approximation of air-shower physics

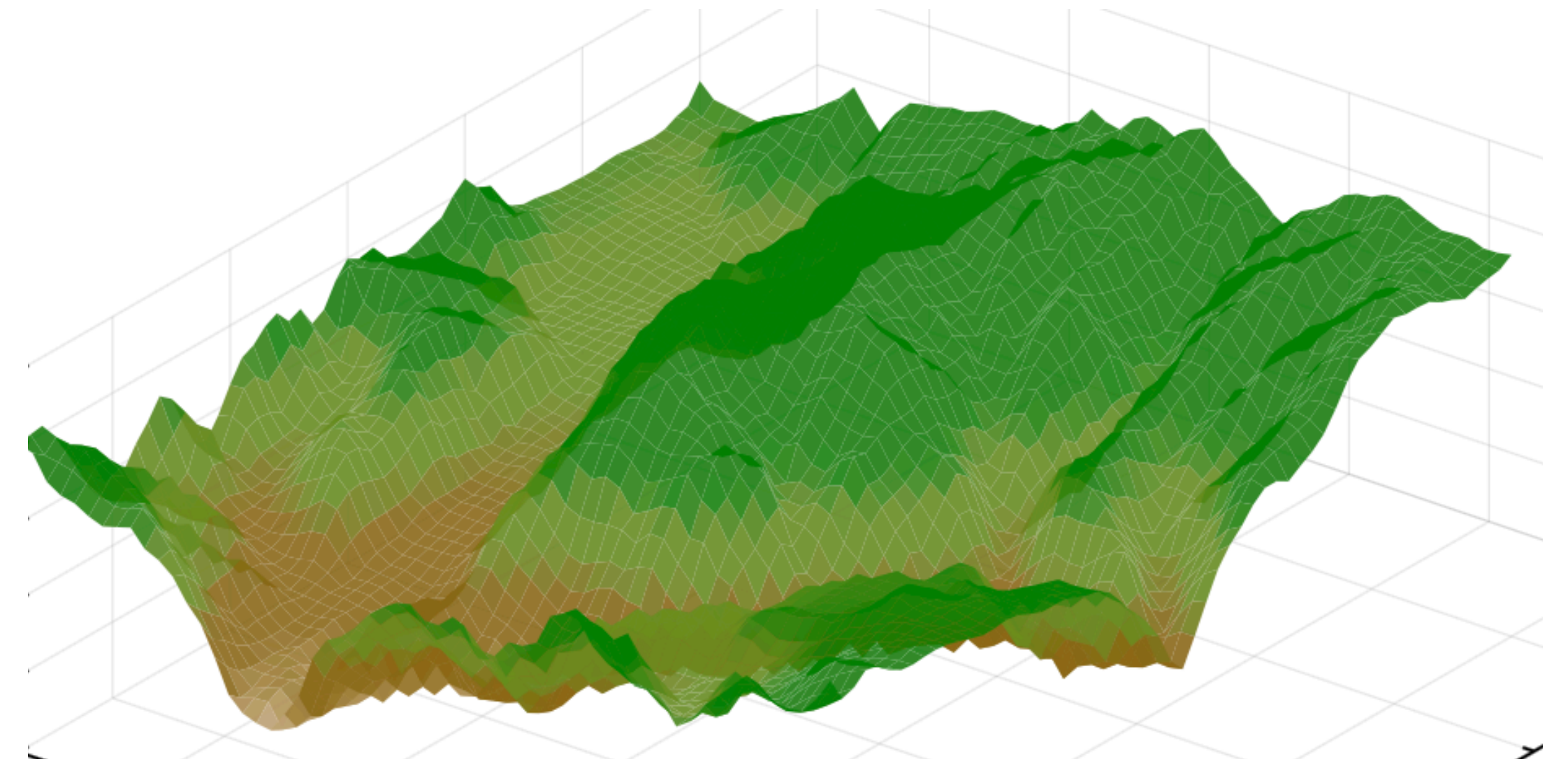

- Realistic valley geometry
- Full treatment of  $\tau^\pm$  energy losses
- (Less) approximation of air-shower physics

# Developing a Full Monte Carlo Chain

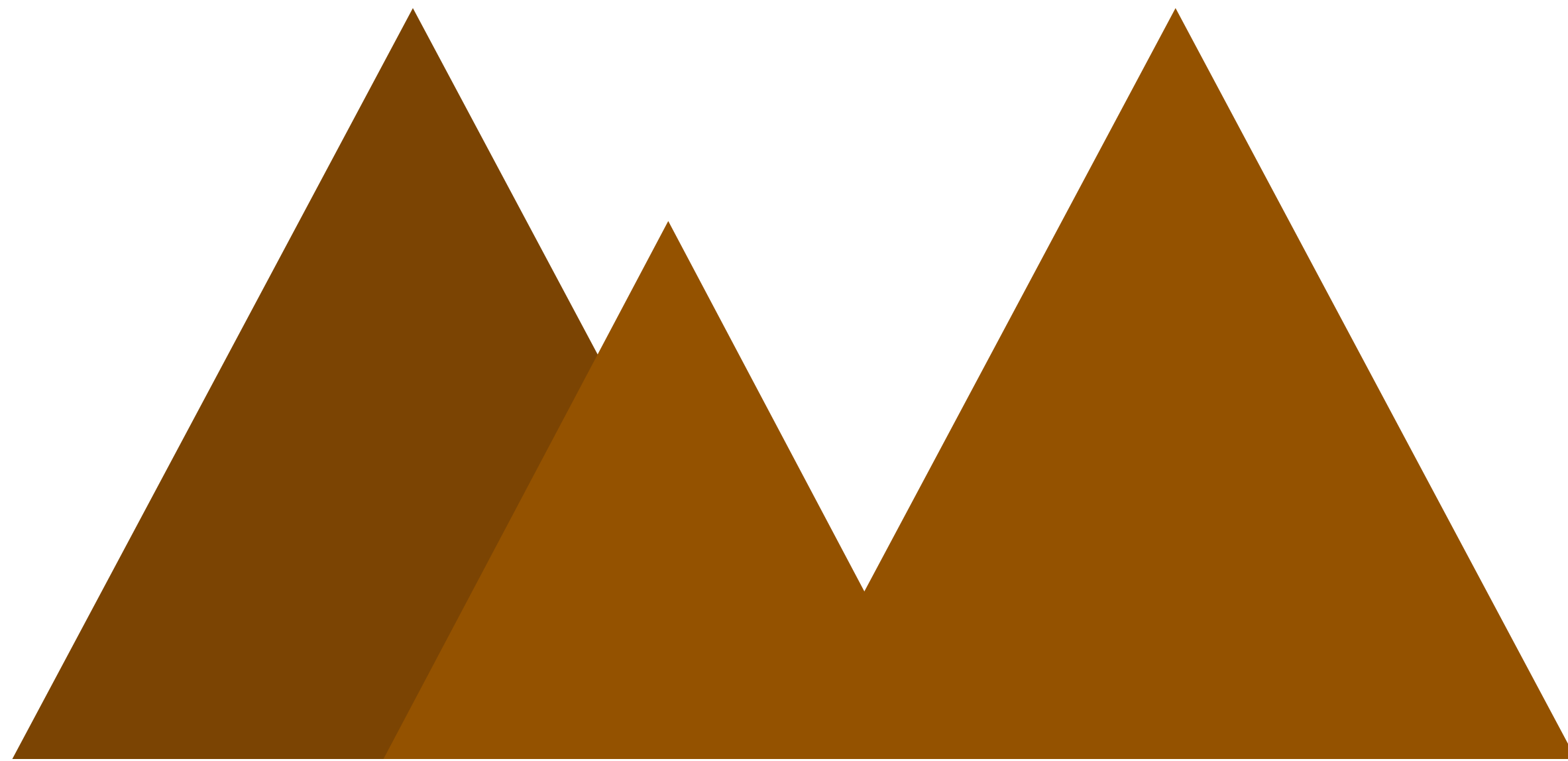

# Developing a Full Monte Carlo Chain

***Initial neutrino injection:*** Select initial neutrino properties, *i.e.* energy, direction, interaction vertex, *etc.*

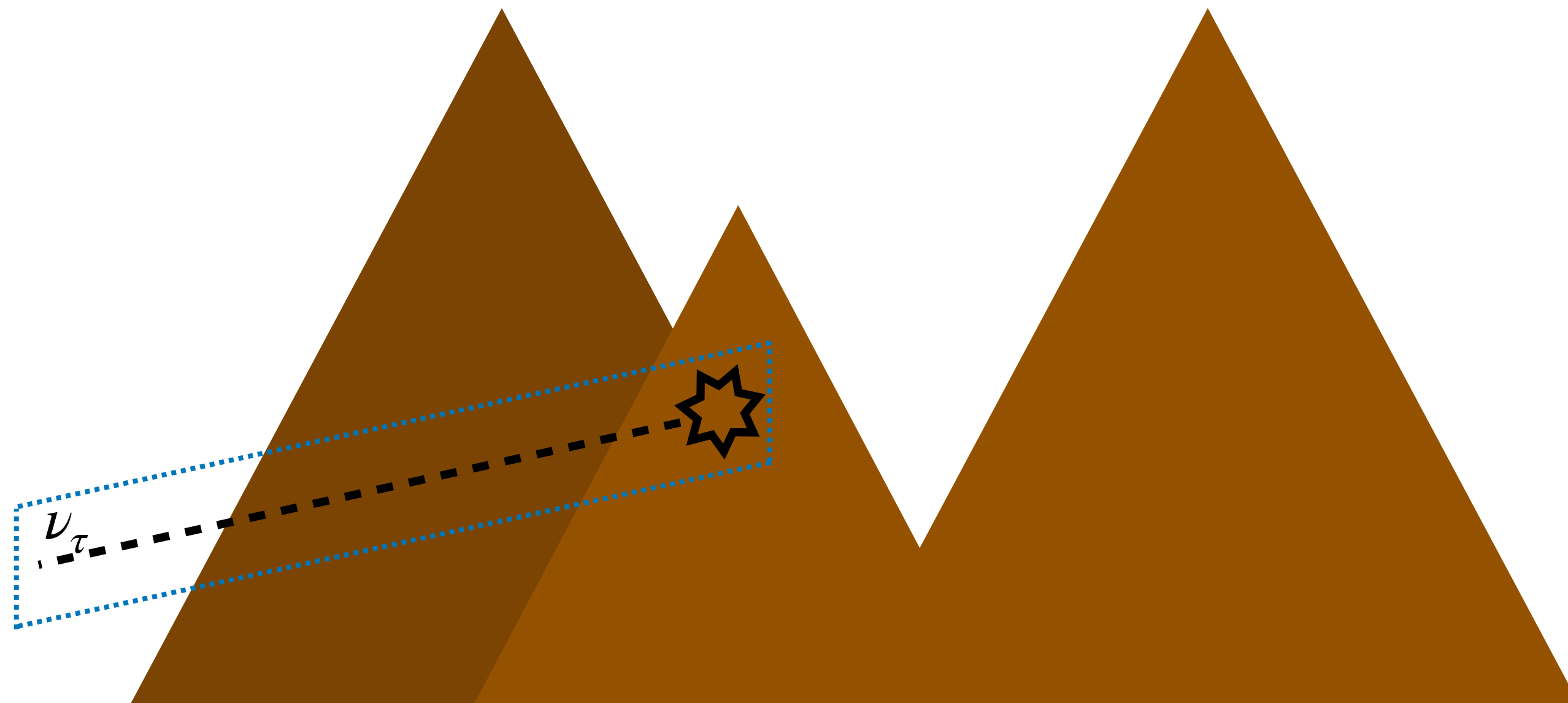

# Developing a Full Monte Carlo Chain

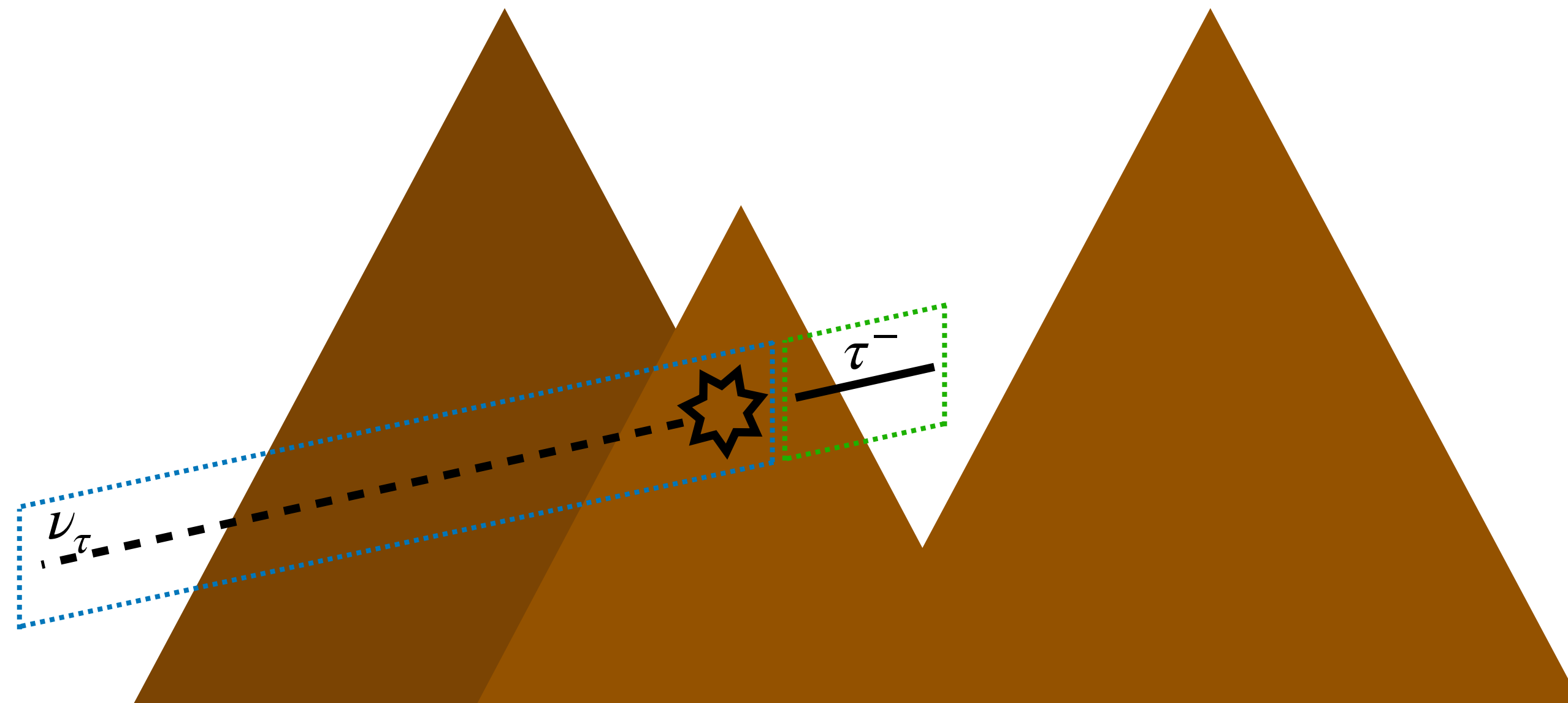

**Initial neutrino injection:** Select initial neutrino properties, *i.e.* energy, direction, interaction vertex, *etc.*

**Charged lepton propagation:** Propagate outgoing charged lepton, accounting for energy losses and decay, to find decay point

# Developing a Full Monte Carlo Chain

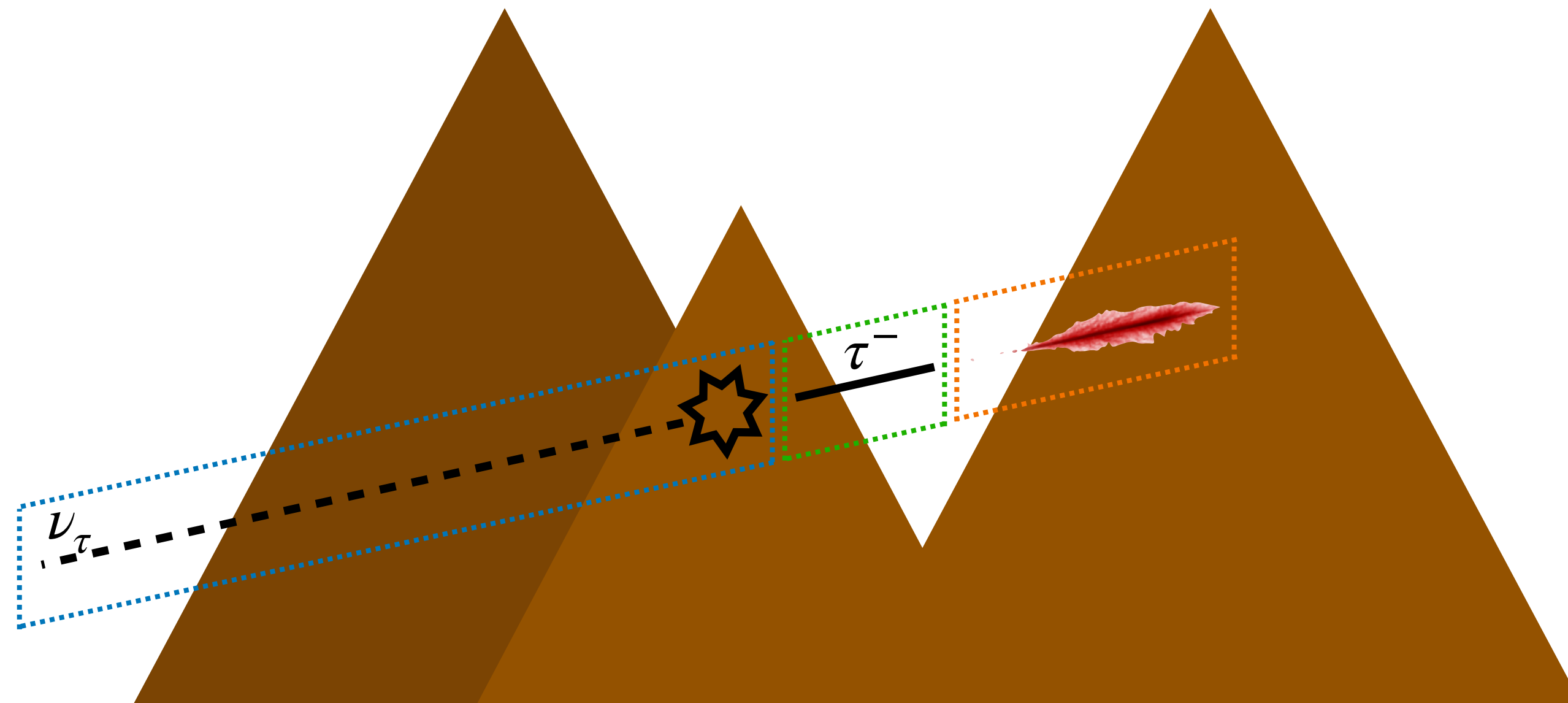

**Initial neutrino injection:** Select initial neutrino properties, *i.e.* energy, direction, interaction vertex, *etc.*

**Charged lepton propagation:** Propagate outgoing charged lepton, accounting for energy losses and decay, to find decay point

**Air-shower simulation:** Model shower development from lepton decay

# Developing a Full Monte Carlo Chain

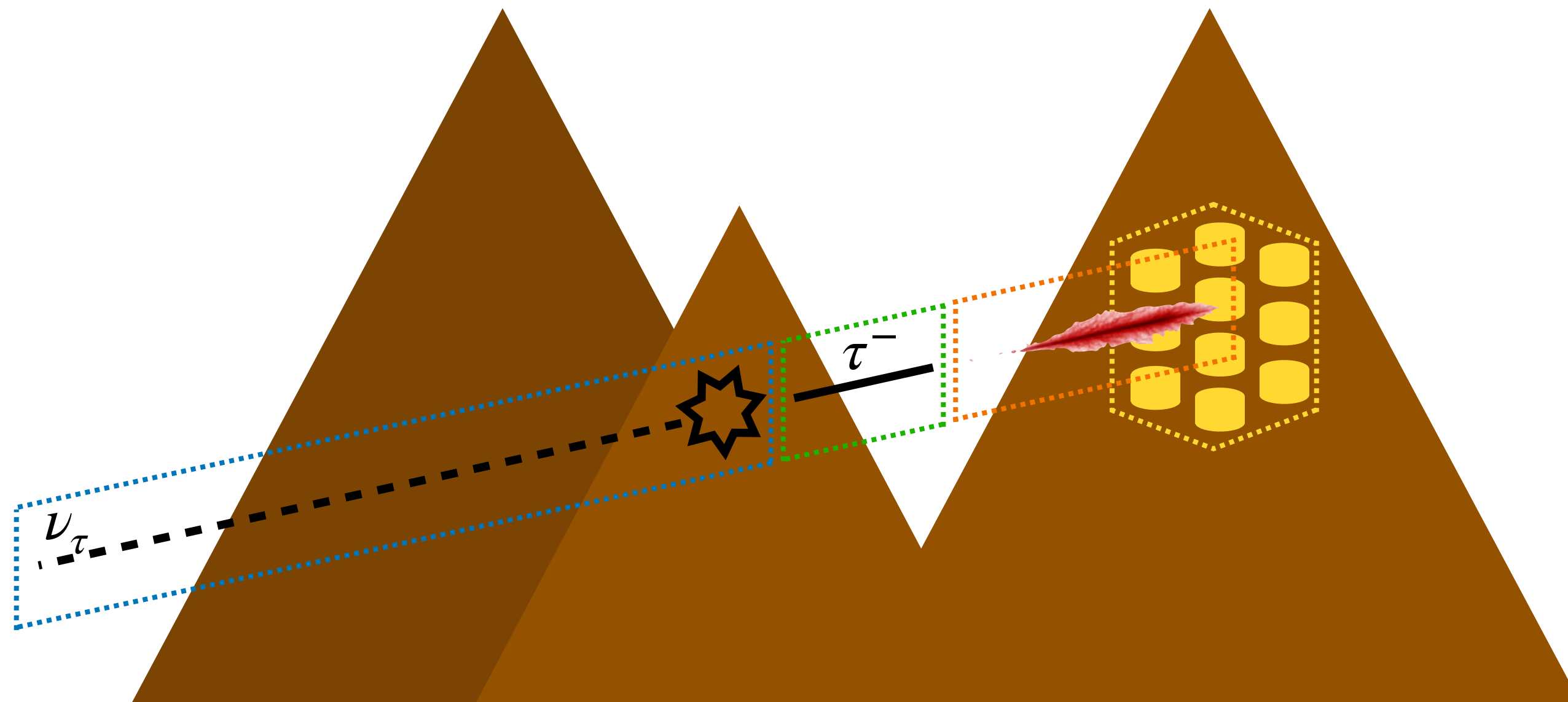

**Initial neutrino injection:** Select initial neutrino properties, *i.e.* energy, direction, interaction vertex, *etc.*

**Charged lepton propagation:** Propagate outgoing charged lepton, accounting for energy losses and decay, to find decay point

**Air-shower simulation:** Model shower development from lepton decay

**Detector response:** Simulate internal hardware to model what we will see

# Developing a Full Monte Carlo Chain

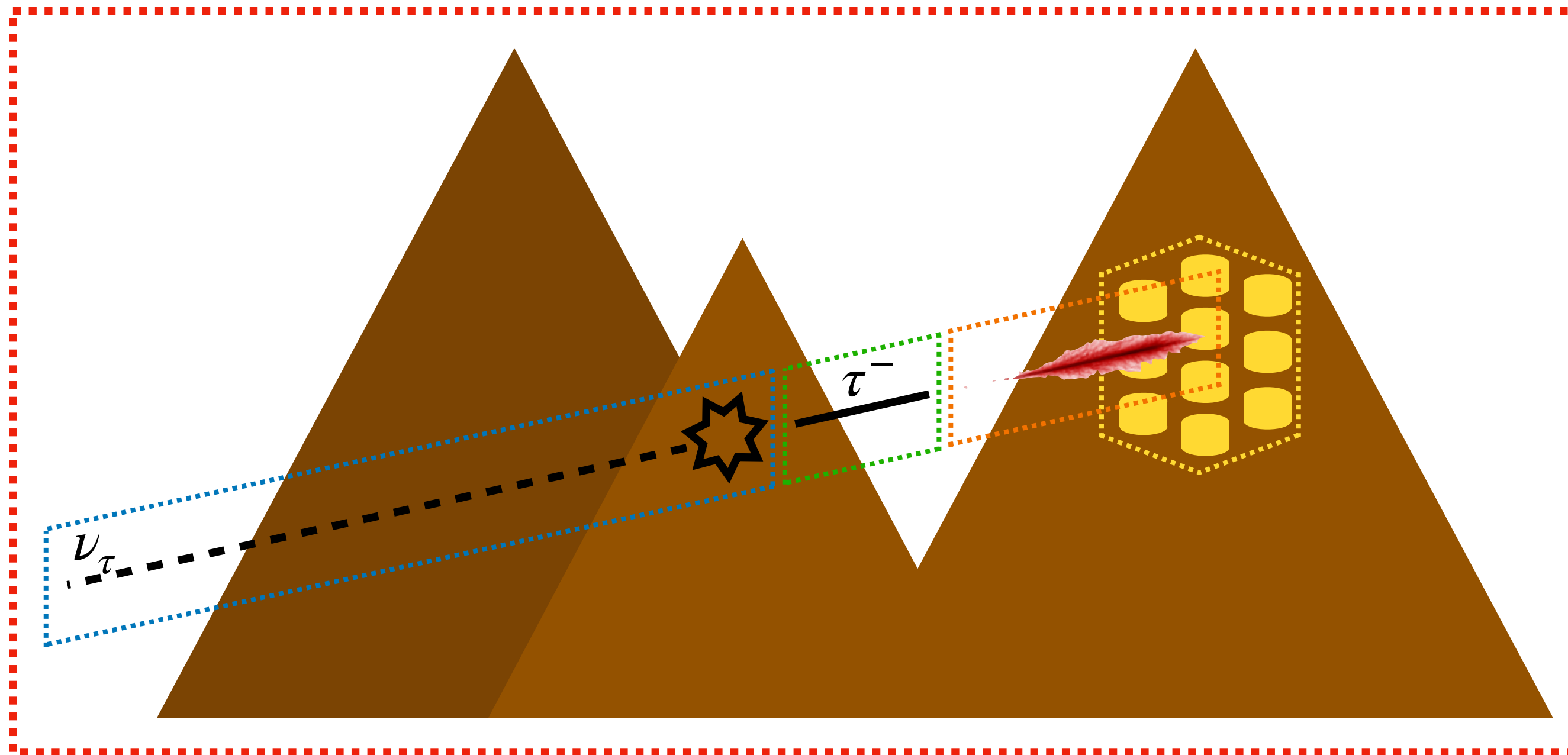

**Initial neutrino injection:** Select initial neutrino properties, *i.e.* energy, direction, interaction vertex, *etc.*

**Charged lepton propagation:** Propagate outgoing charged lepton, accounting for energy losses and decay, to find decay point

**Air-shower simulation:** Model shower development from lepton decay

**Detector response:** Simulate internal hardware to model what we will see

**Event weighting:** Remove unphysical remnants from selection of initial neutrino properties

# Full Timing Information

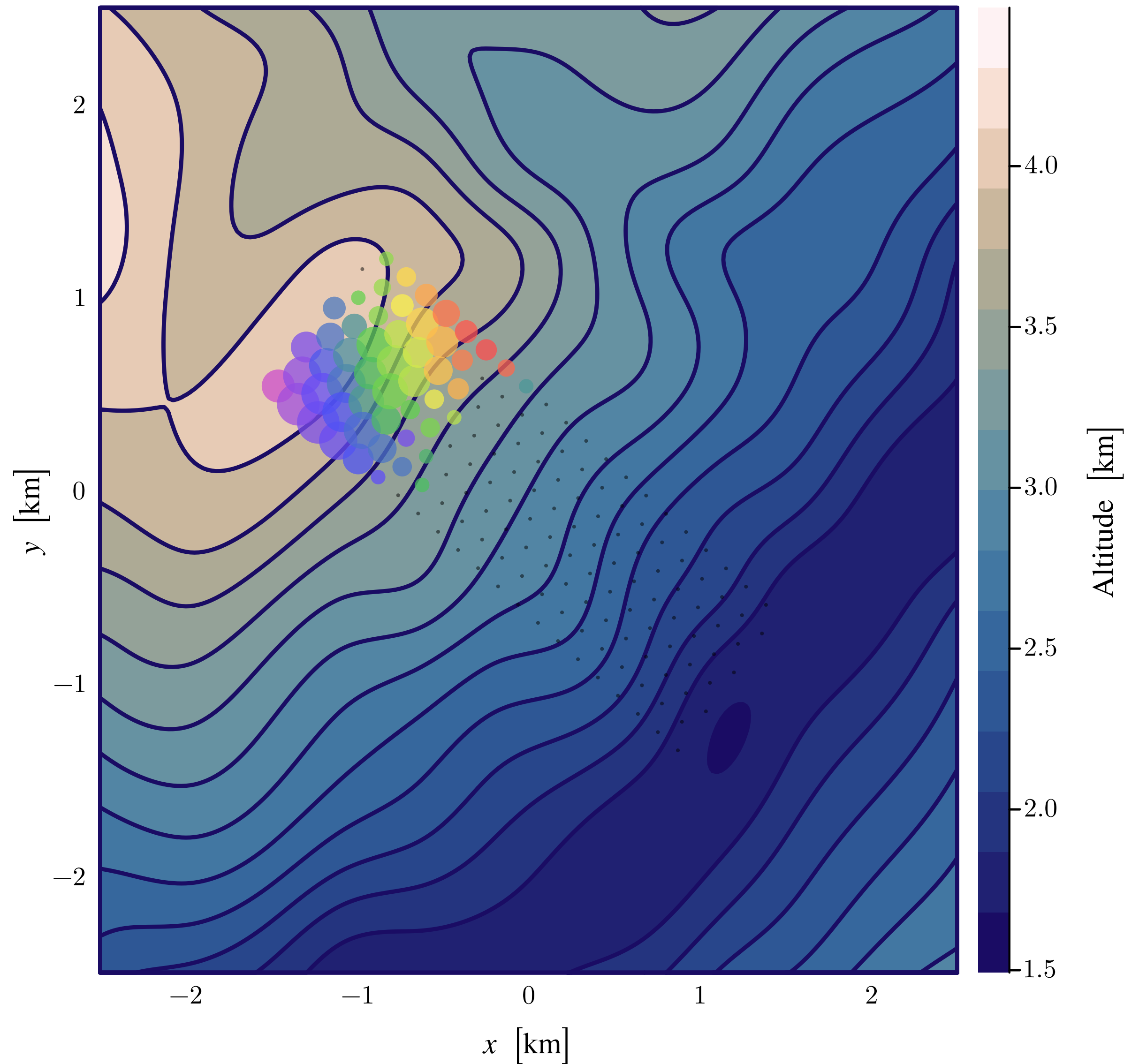

- In addition to more accurate rate predictions, full MC enables:
  1. Pretty event displays
  2. Reconstruction development
- We are currently working with GraphNeT developers to make a preliminary reconstruction

# Updated Event Rates

Solid: Updated MC prediction  
Dashed: Initial estimation

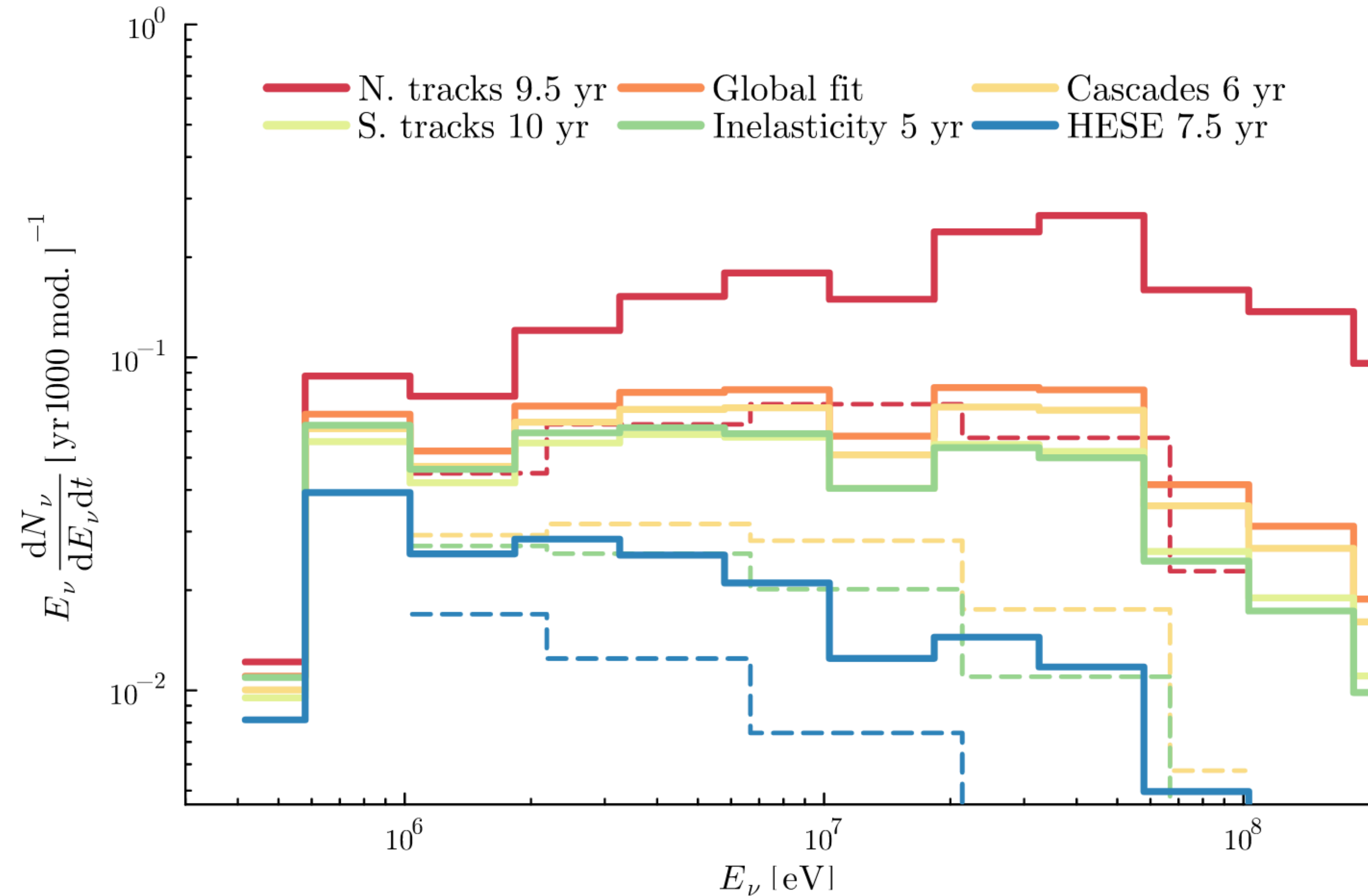

- Rates from the new calculation higher than initial estimation by a factor of ~2-3
- This ratio grows at the highest energies

# Event Rates from Different Spectra

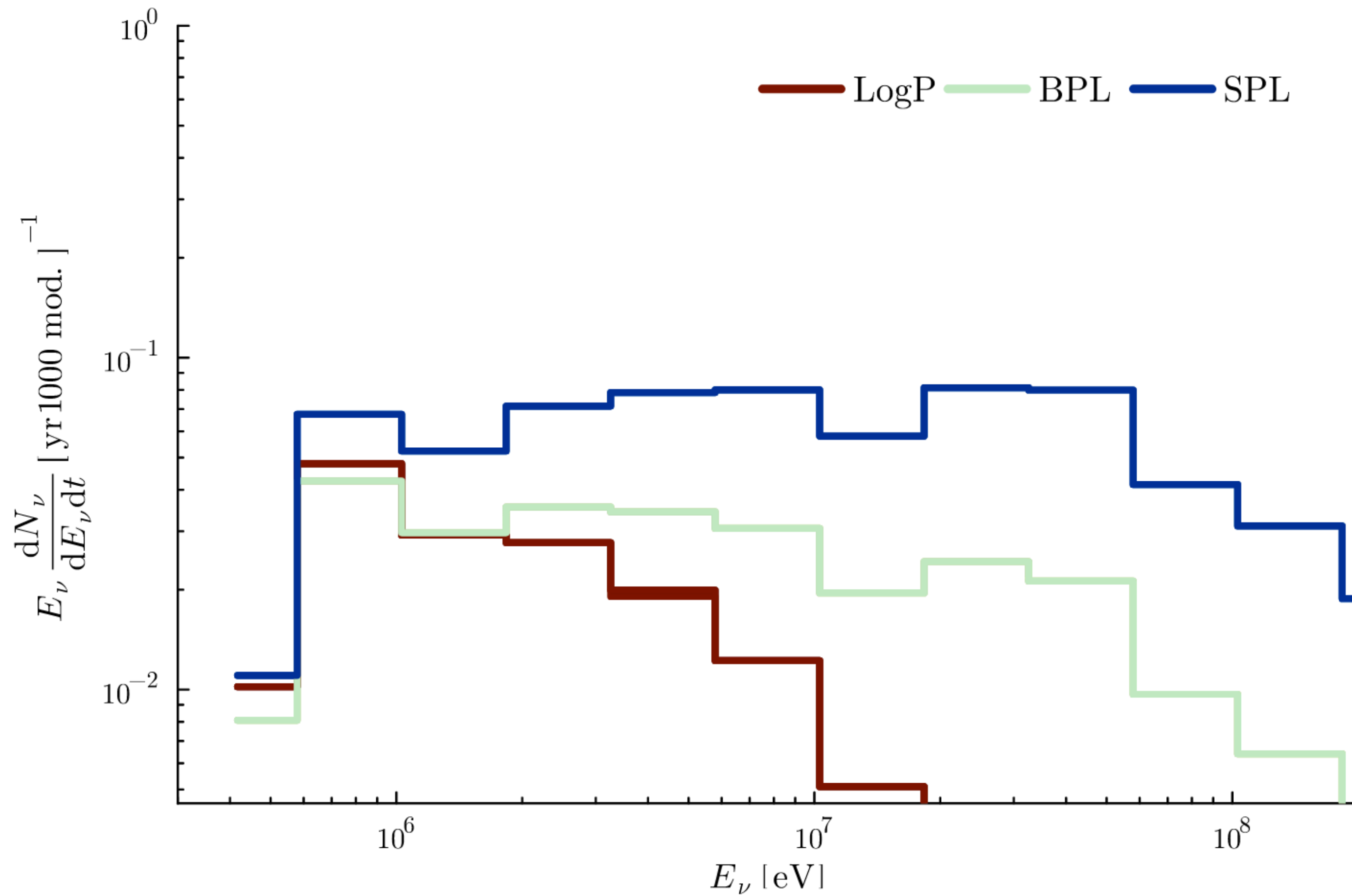

- In three years of data-taking on a 5000 module detector, we will be able to reject the SPL at  $> 3\sigma$

# Tentative Timeline

- Initially deploy ~10 modules for detector R&D
- Follow with ~100 modules for array R&D
- Full array could be deployed in 1500-module segments

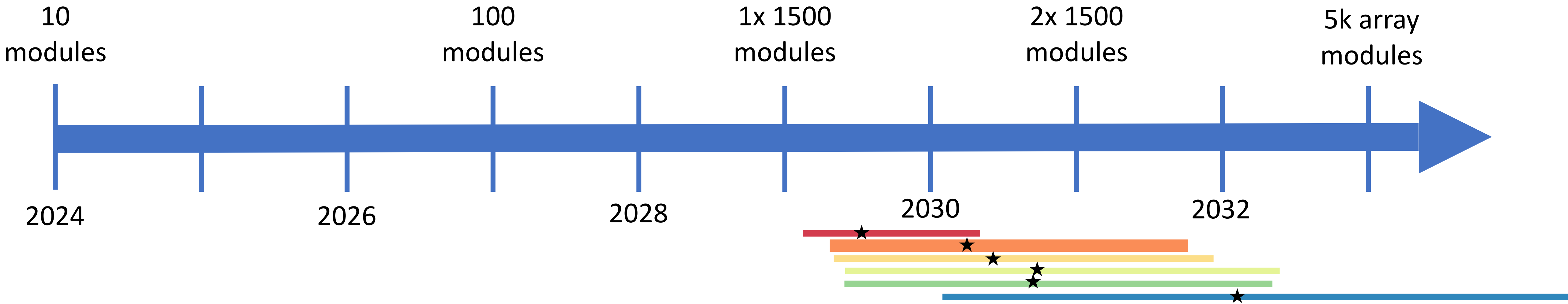

# Commitment to Equity through Particle Physics

- Met with the mayor of Chivay to discuss potential partnerships between the collaboration and the local community
- Recently held a workshop at the Harvard Radcliffe Institute to explore different sociological aspects of particle physics experiments in different cultural contexts



# Conclusions

- Neutrino telescopes have been crucial tools for understanding many areas of physics
- IceCube has opened the door to the neutrino Universe, with the most recent results showing the first evidence of galactic and extragalactic neutrino sources, world-leading limits on dark matter cross sections, and competitive results for neutrino oscillation parameters
- Neutrino telescopes that are sensitive to higher energy neutrinos, especially those in the energy range just above IceCube, will prove crucial to resolving some currently difficult problems

# Thank you :-)

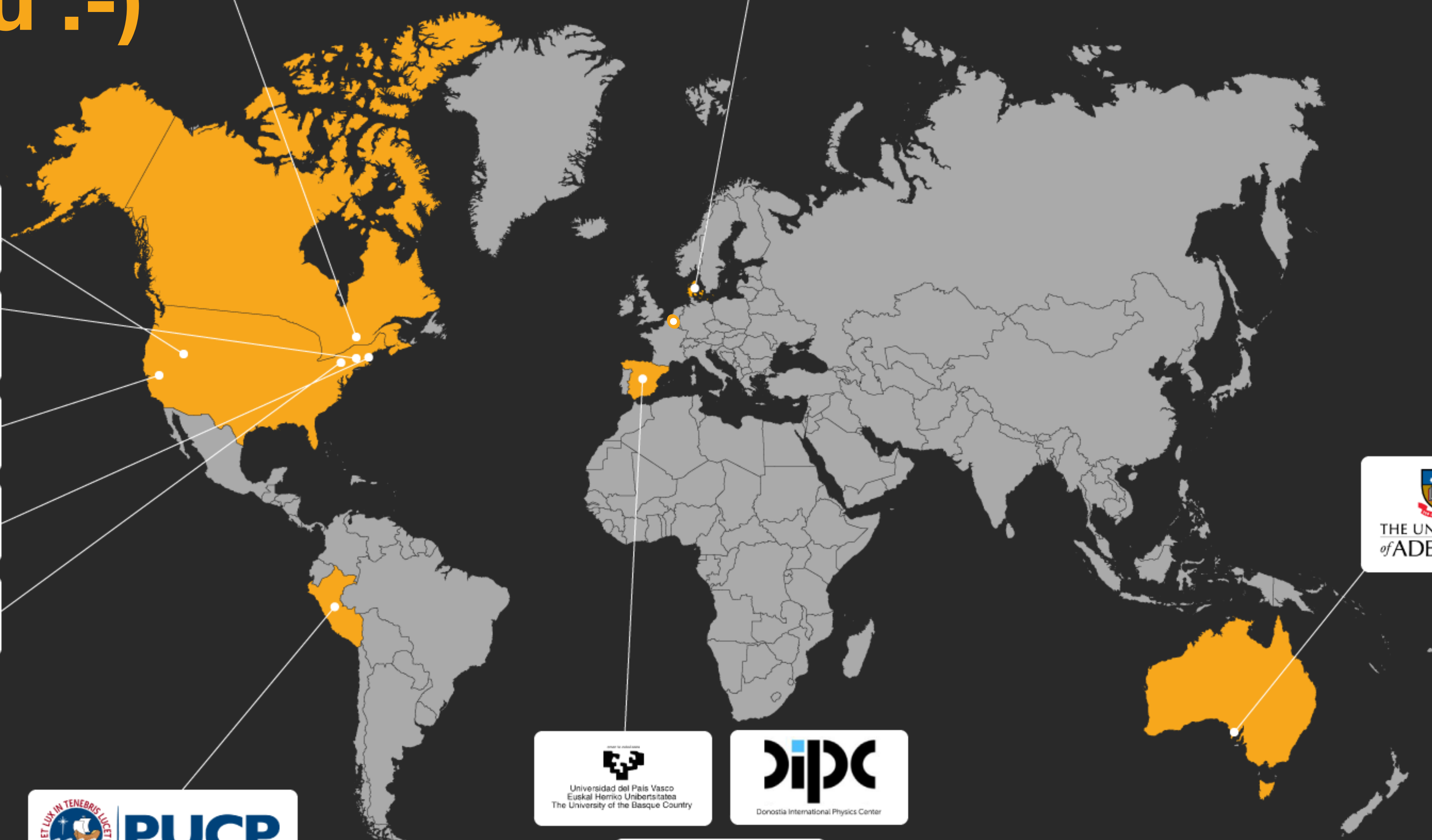
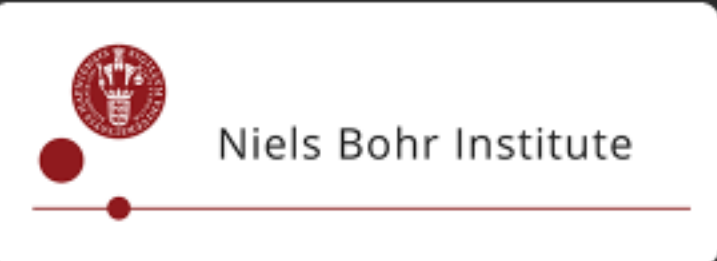

# Backups

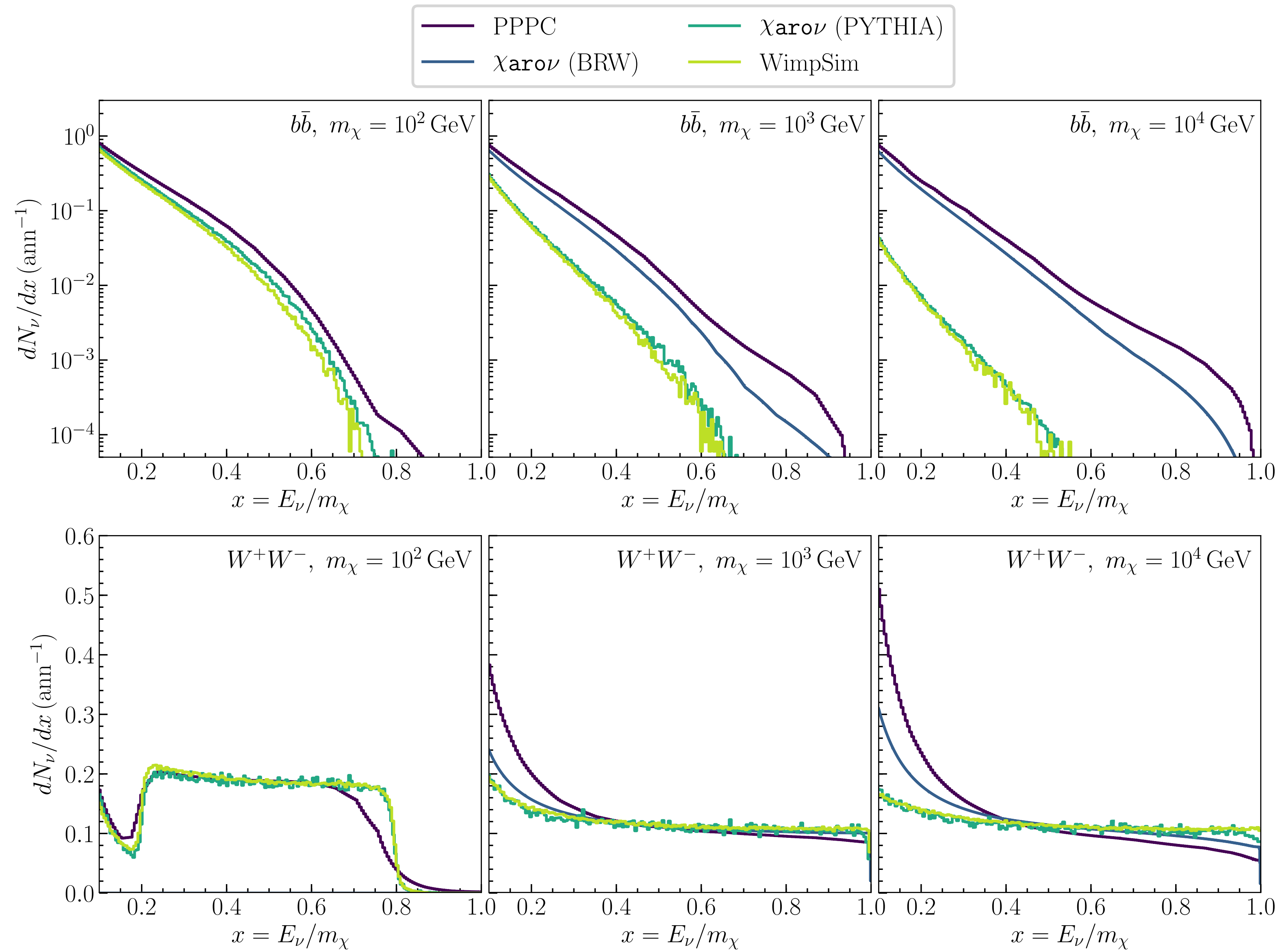

Reaction	Label	Flux ( $\text{cm}^{-2} \text{s}^{-1}$ )
$p + p \rightarrow {}^2\text{H} + e^+ + \nu_e$	<i>pp</i>	$5.95 \times 10^{10}$
$p + e^- + p \rightarrow {}^2\text{H} + \nu_e$	<i>pep</i>	$1.40 \times 10^8$
${}^3\text{He} + p \rightarrow {}^4\text{He} + e^+ + \nu_e$	<i>hep</i>	$9.3 \times 10^3$
${}^7\text{Be} + e^- \rightarrow {}^7\text{Li} + \nu_e$	${}^7\text{Be}$	$4.77 \times 10^9$
${}^8\text{B} \rightarrow {}^8\text{Be}^* + e^+ + \nu_e$	${}^8\text{B}$	$5.05 \times 10^6$

