

# Radiative b-baryon decays at LHCb

Luis Miguel Garcia Martin

IFIC seminar  
October 5th, 2021



## 1 Introduction

- Theoretical framework
- LHCb Detector
- Experimental status with other rare decays

## 2 Radiative Decays

- Experimental challenges
- Analyses

## 3 Conclusions



## 1 Introduction

- Theoretical framework
- LHCb Detector
- Experimental status with other rare decays

## 2 Radiative Decays

- Experimental challenges
- Analyses

## 3 Conclusions



# Introduction: Flavour

In the Standard Model (SM), transitions between different quarks are governed by the CKM mechanism:

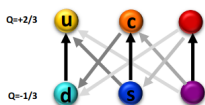

$$V_{\text{CKM}} = \begin{pmatrix} V_{ud} & V_{us} & V_{ub} \\ V_{cd} & V_{cs} & V_{cb} \\ V_{td} & V_{ts} & V_{tb} \end{pmatrix}$$

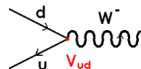

# Introduction: Flavour

In the Standard Model (SM), transitions between different quarks are governed by the CKM mechanism:

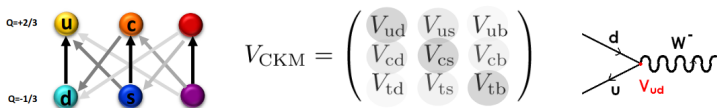

- Flavour is a powerful tool to search for New Physics indirectly
- Look for inconsistencies with the Standard Model picture
- Sensitive to large energy scales, beyond the reach of direct searches
- Could be the first place we see hints of something new!



# Introduction: $b \rightarrow s, d$ processes

Flavour Changing Neutral Currents are forbidden in SM at tree level:

- Supressed (Rare processes)
- Potential interferences from NP diagrams
- NP contributions could significantly change the value of observables

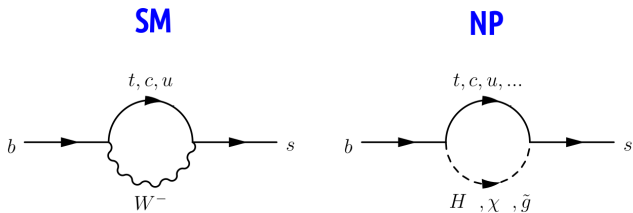

# Introduction: $b \rightarrow s, d$ processes

Flavour Changing Neutral Currents are forbidden in SM at tree level:

- Suppressed (Rare processes)
- Potential interferences from NP diagrams
- NP contributions could significantly change the value of observables

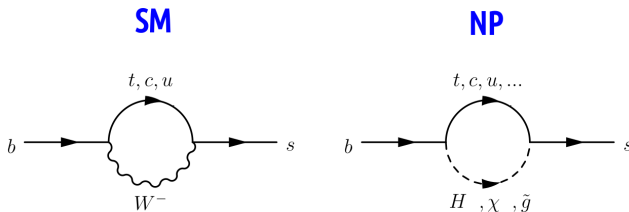

Why B decays?

- The b-quark is the heaviest quark forming hadronic bound states ( $m \sim 4.7$  GeV)
- Long lifetime ( $\sim 1.6$  ps) [Good for experimentalists]
- Many accessible decay channels (small BR's)



# Introduction: OPE

Model independent description by EFT: Operator product expansion.

$$H_{\text{eff}} = -\frac{4G_F}{\sqrt{2}} V_{tb} V_{ts}^* \sum_i \left[ \underbrace{C_i(\mu) \mathcal{O}_i(\mu)}_{\text{left-handed part}} + \underbrace{C'_i(\mu) \mathcal{O}'_i(\mu)}_{\text{right-handed part}} \right]$$

$i=1, 2$	Tree
$i=3-6, 8$	Gluon penguin
$i=7$	Photon penguin
$i=9, 10$	Electroweak penguin
$i=S$	Higgs (scalar) penguin
$i=P$	Pseudoscalar penguin

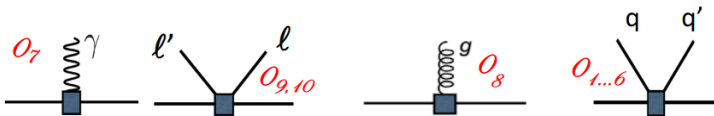

# Introduction: OPE

Model independent description by EFT: Operator product expansion.

$$H_{\text{eff}} = -\frac{4G_F}{\sqrt{2}} V_{tb} V_{ts}^* \sum_i \left[ \underbrace{C_i(\mu) \mathcal{O}_i(\mu)}_{\text{left-handed part}} + \underbrace{C'_i(\mu) \mathcal{O}'_i(\mu)}_{\text{right-handed part}} \right]$$

i=1, 2	Tree
i=3-6, 8	Gluon penguin
i=7	Photon penguin
i=9, 10	Electroweak penguin
i=S	Higgs (scalar) penguin
i=P	Pseudoscalar penguin

- $W^-$  bosons only couple to left-handed quarks  $\implies$  right-handed currents suppressed
- Wilson Coefficients ( $C_i$ ) parametrize coupling strength and describe loop part of the diagrams
- Looking for deviation w.r.t SM prediction:

$$\begin{cases} C_i = C_i^{SM} + C_i^{NP} \\ C'_i = C_i'^{NP} \end{cases}$$



# Introduction: OPE

Model independent description by EFT: Operator product expansion.

$$H_{\text{eff}} = -\frac{4G_F}{\sqrt{2}} V_{tb} V_{ts}^* \sum_i \left[ \underbrace{C_i(\mu) \mathcal{O}_i(\mu)}_{\text{left-handed part}} + \underbrace{\cancel{C'_i(\mu)} \mathcal{O}'_i(\mu)}_{\substack{\text{right-handed part} \\ \text{suppressed in SM}}} \right]$$

i=1, 2	Tree
i=3-6, 8	Gluon penguin
i=7	Photon penguin
i=9, 10	Electroweak penguin
i=S	Higgs (scalar) penguin
i=P	Pseudoscalar penguin

- $W^-$  bosons only couple to left-handed quarks  $\implies$  right-handed currents suppressed
- Wilson Coefficients ( $C_i$ ) parametrize coupling strength and describe loop part of the diagrams
- Looking for deviation w.r.t SM prediction:

$$\begin{cases} C_i = C_i^{SM} + C_i^{NP} \\ C'_i = C_i^{NP} \end{cases}$$



# LHCb detector

- One of the four detectors at LHC
- LHCb is a single-arm ( $2 < \eta < 5$ ) spectrometer
  - Optimised for beauty and charm decays

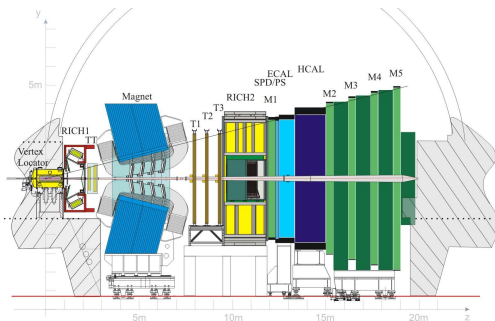

$$\eta = -\ln \left[ \tan \left( \frac{\theta}{2} \right) \right]$$

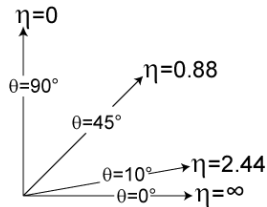

$\theta$ : Angle between  $\mathbf{p}$  and positive beam axis.



# LHCb detector

- One of the four detectors at LHC
- LHCb is a single-arm ( $2 < \eta < 5$ ) spectrometer
  - Optimised for beauty and charm decays

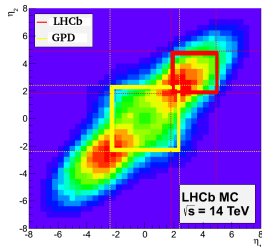
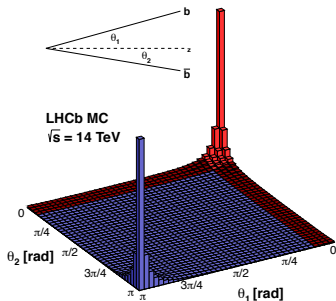

# LHCb detector

- One of the four detectors at LHC
- LHCb is a single-arm ( $2 < \eta < 5$ ) spectrometer
  - Optimised for beauty and charm decays
- Runs at lower luminosity
  - Optimised for precision measurements

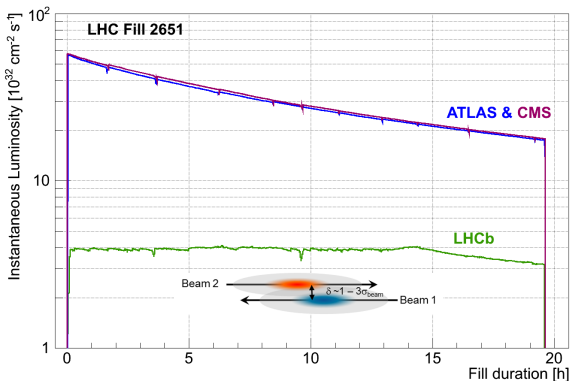

# LHCb Detector

Integrated Luminosity:

- Run I (2011-2012):  $3 \text{ fb}^{-1}$
- Run II (2015-2018):  $6 \text{ fb}^{-1}$

$1 \text{ fb}^{-1} \approx 10^{12}$  pp collisions

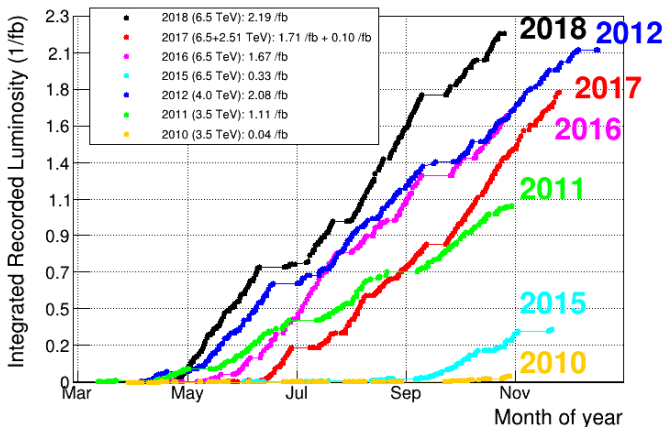

# LHCb detector

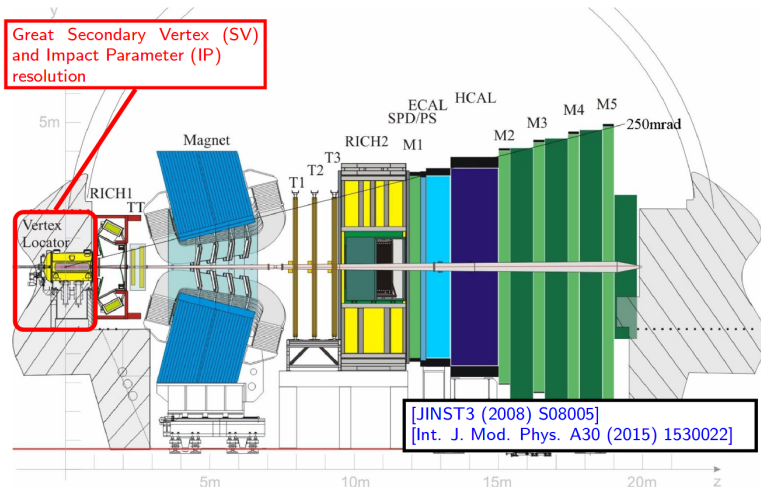

$$\Delta IP = (16 + 29/p_T [\text{GeV}]) \mu\text{m}$$



# LHCb detector

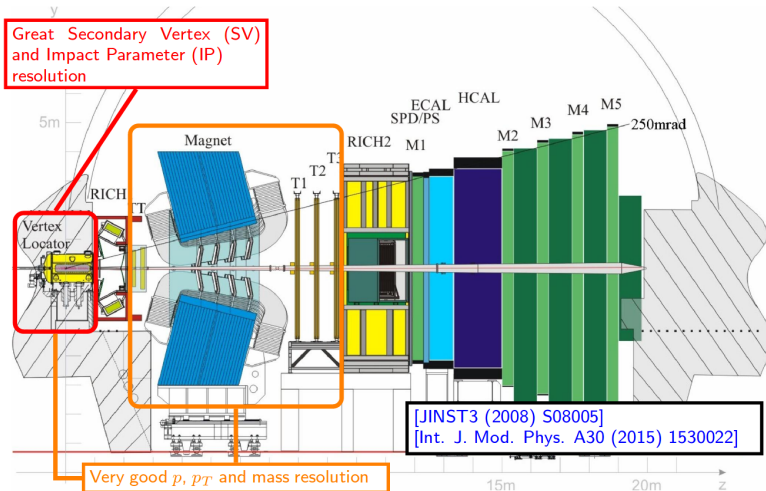

$$\Delta p/p = 0.5 - 1.0\%$$



# LHCb detector

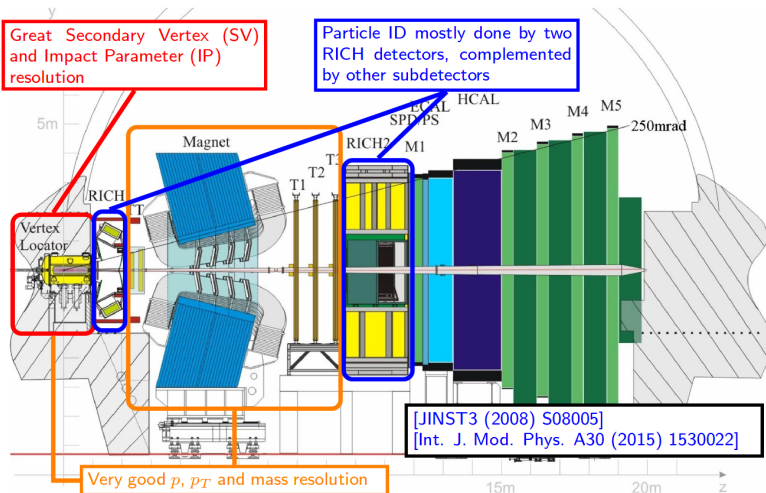

Kaon ID  $\sim 95\%$  for  $\sim 5\% \pi \rightarrow K$  mis-id probability



# LHCb detector

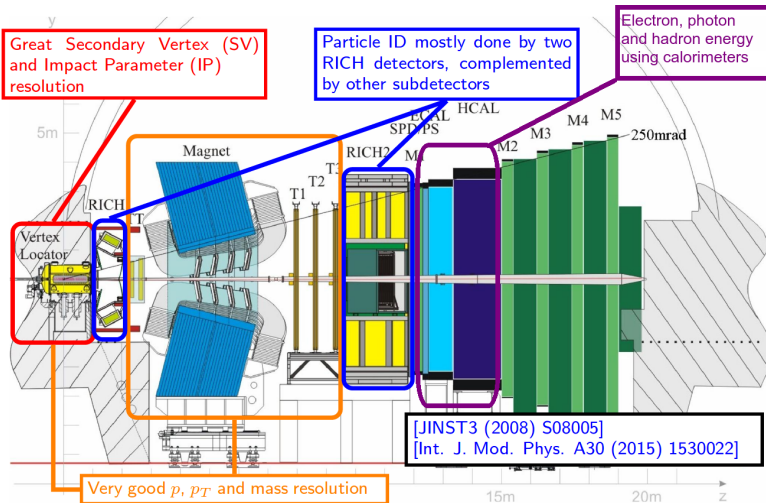

Electron ID  $\sim 90\%$  for  $\sim 5\%$   $e \rightarrow h$  mis-id probability  
 $\Delta E/E_{\text{ECAL}} = 1\% + 10.0\%/\sqrt{E[\text{GeV}]}$



# LHCb detector

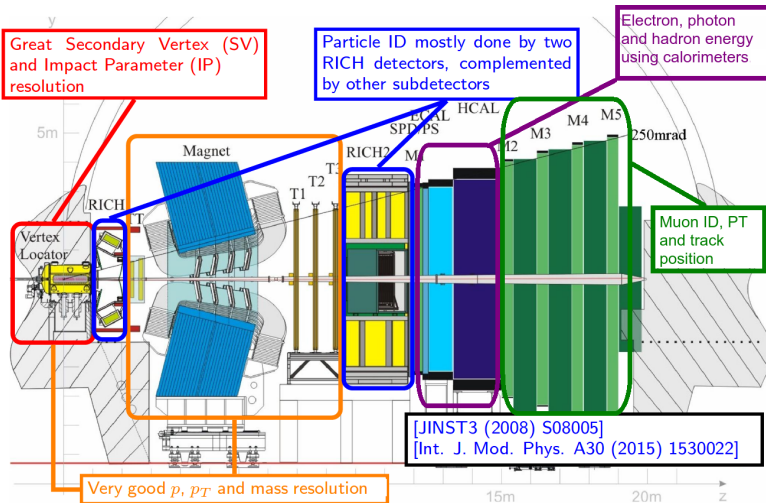

Muon ID  $\sim 97\%$  for  $\sim 1\text{-}3\% \pi \rightarrow \mu$  mis-id probability



# LHCb detector

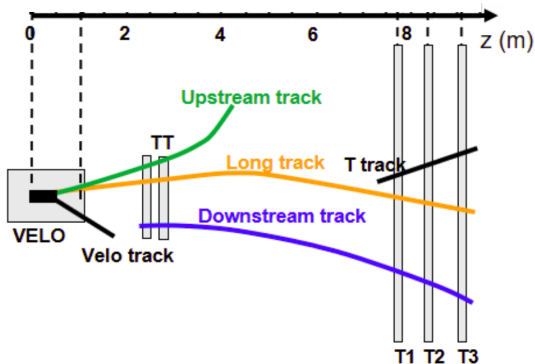

## Long tracks

- Hits at least in VELO and T stations
- Used in majority of analyses

## Downstream tracks

- Hits in TT and T stations (not in VELO)
- Decay products of long-lived particles



# Experimental status: $B_{(s)} \rightarrow \mu\mu$

Fully leptonic final state ( $b \rightarrow \ell\ell$ )

- Very precise SM prediction [JHEP 10(2019)232]
  - $\mathcal{B}(B_s \rightarrow \mu\mu)_{SM} = (3.66 \pm 0.14) \times 10^{-9}$
  - $\mathcal{B}(B \rightarrow \mu\mu)_{SM} = (1.03 \pm 0.05) \times 10^{-10}$
- Sensitive to new (pseudo-)scalar contributions

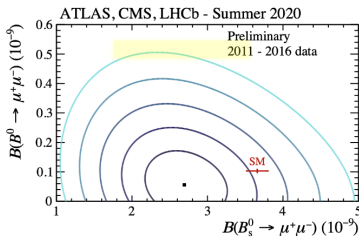
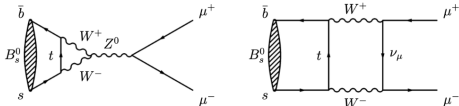

[LHCb-CONF-2020-002,  
CMS PAS BPH-20-003,  
ATLAS-CONF-2020-049]

$$\mathcal{B}(B_s^0 \rightarrow \mu^+\mu^-) = (2.69^{+0.37}_{-0.35}) \times 10^{-9}$$

$$\mathcal{B}(B^0 \rightarrow \mu^+\mu^-) < 1.9 \times 10^{-10} \text{ (95 \% CL)}$$

Compatible with the SM at  $2.1\sigma$



# Experimental status: $B_{(s)} \rightarrow \mu\mu$

New measurement from LHCb using  $9 \text{ fb}^{-1}$   
 [arXiv:2108.09283 and 2108.09284v2]

- $\mathcal{B}(B_s \rightarrow \mu\mu) = (3.66_{-0.43}^{+0.46} \quad {}_{0.11}^{+0.15}) \times 10^{-9}$
- $\mathcal{B}(B \rightarrow \mu\mu) < 2.6 \times 10^{-10}$  (95% CL)
- Set a limit also for the radiative decay  
 $\mathcal{B}(B_s \rightarrow \mu\mu\gamma) < 2.0 \times 10^{-10}$  (95% CL)

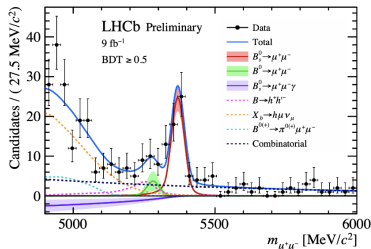

$B \rightarrow \mu\mu$  still not observed

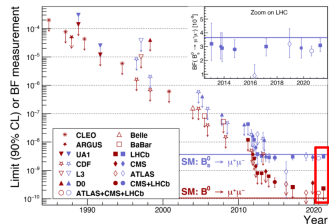

# Experimental status: $B_s \rightarrow \phi \mu \mu$

Semileptonic rare decays ( $b \rightarrow s \ell \ell$ ) offer a rich phenomenology

Each  $q^2$  region probes different processes:

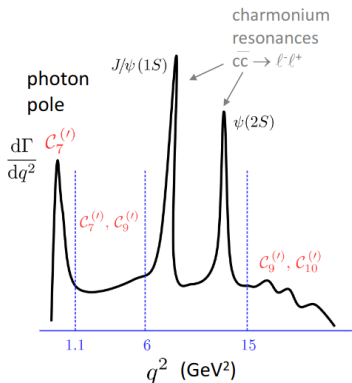
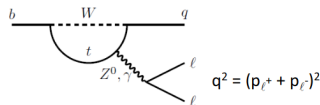

# Experimental status: $B_s \rightarrow \phi \mu \mu$

- New LHCb measurement using 9 fb<sup>-1</sup>
  - $\frac{dB}{dq^2} = (2.88 \pm 0.21) \times 10^{-8}$  [arXiv:2105.14007]
- Tension with the SM at 3.6 $\sigma$  level
  - (1.8 $\sigma$  with LCSR alone)

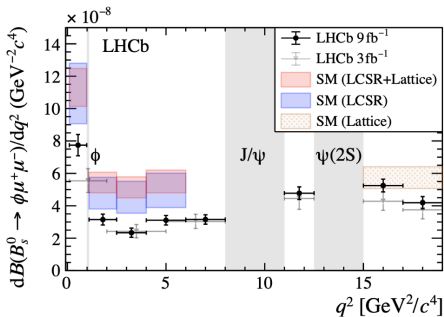

Results in other channels:

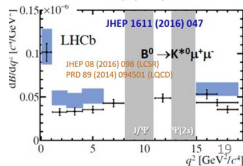
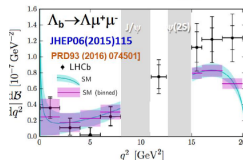
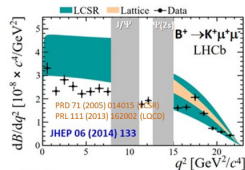

# Experimental status: $B_s \rightarrow \phi \mu \mu$ angular analysis

Complementary constraints on NP and orthogonal experimental systematics compared to BR's

- For  $B \rightarrow V \ell \ell$ , differential decay rate can be described by 3 angles and  $q^2$ :

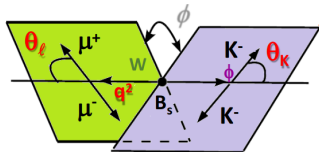

$$\frac{1}{d(\Gamma + \bar{\Gamma})/dq^2} \frac{d^3(\Gamma + \bar{\Gamma})}{d \cos \theta_l d \cos \theta_K d \phi}$$

$$= \frac{9}{32\pi} \left[ \frac{3}{4}(1 - F_L) \sin^2 \theta_K (1 + \frac{1}{3} \cos 2\theta_l) \right.$$

$$+ F_L \cos^2 \theta_K (1 - \cos 2\theta_l) + S_3 \sin^2 \theta_K \sin^2 \theta_l \cos 2\phi$$

$$+ S_4 \sin 2\theta_K \sin 2\theta_l \cos \phi + A_5 \sin 2\theta_K \sin \theta_l \cos \phi$$

$$+ \frac{4}{3} A_{FB}^{CP} \sin^2 \theta_K \cos \theta_l + S_7 \sin 2\theta_K \sin \theta_l \sin \phi$$

$$\left. + A_8 \sin 2\theta_K \sin 2\theta_l \sin \phi + A_9 \sin^2 \theta_K \sin^2 \theta_l \sin 2\phi \right]$$

- Give access to observables related to CP-averages and asymmetries:  
 $F_L, A_{FB}, S_i, A_i$

# Experimental status: $B_s \rightarrow \phi \mu \mu$ angular analysis

New analysis using  $8.4 \text{ fb}^{-1}$  LHCb data [arXiv:2107.13428]

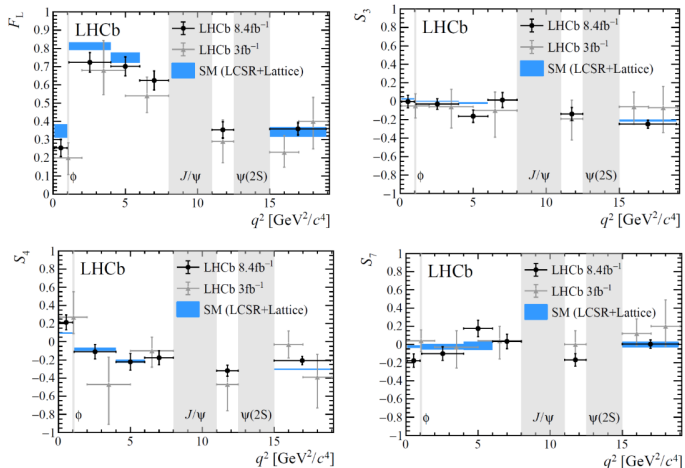

In general good agreement with SM, deviations less than  $2\sigma$



# Experimental status: $B \rightarrow K^* \mu \mu$ angular analysis

Two new analyses by LHCb with  $9 \text{ fb}^{-1}$ :

- Angular analysis of  $B^+ \rightarrow K^{*+} \mu \mu$  [PRL126(2021)161802]
- Angular analysis of  $B^0 \rightarrow K^{*0} \mu \mu$  [PRL125(2020)011802]

Self-tagging final state ( $K^* \rightarrow K^+ \pi^-$ ) allow access to more observables:

- Give access to observables with reduced dependence on hadronic effects:

$$P'_5 = \frac{S_5}{F_L(1-F_L)}$$

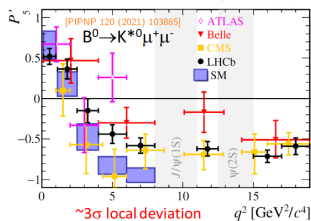

# Experimental status: $B \rightarrow K^* \mu \mu$ angular analysis

Two new analyses by LHCb with  $9 \text{ fb}^{-1}$ :

- Angular analysis of  $B^+ \rightarrow K^{*+} \mu \mu$  [PRL126(2021)161802]
- Angular analysis of  $B^0 \rightarrow K^* \mu \mu$  [PRL125(2020)011802]

Self-tagging final state ( $K^* \rightarrow K^+ \pi^-$ ) allow access to more observables:

- Give access to observables with reduced dependence on hadronic effects:

$$P'_5 = \frac{S_5}{F_L(1-F_L)}$$

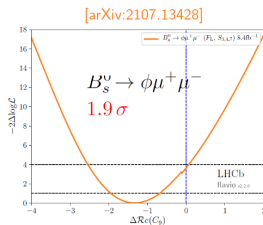
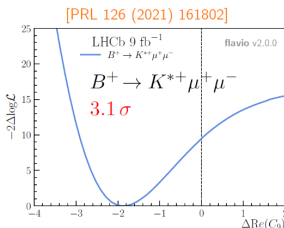
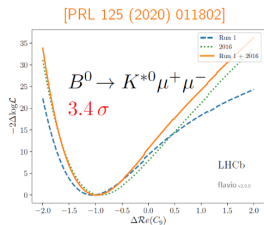

# Experimental status: Lepton universality

In the SM all leptons are expected to behave in the same way:

- Test of lepton universality:  $R_K = \frac{\mathcal{B}(B^+ \rightarrow K^+ \mu^+ \mu^-)}{\mathcal{B}(B^+ \rightarrow K^+ e^+ e^-)} = 1 + \mathcal{O}\left(\frac{m_\mu^2}{m_e^2}\right)$
- Precise theory prediction due to cancellation of hadronic form factor uncertainties
- Challenging due to bremsstrahlung by electrons

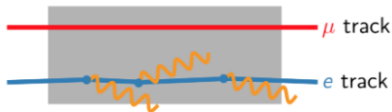

- Experimentally, we perform a double ratio to cancel systematic uncertainties

$$R_K = \frac{\mathcal{B}(B^+ \rightarrow K^+ \mu^+ \mu^-)}{\mathcal{B}(B^+ \rightarrow K^+ J/\psi(\mu^+ \mu^-))} / \frac{\mathcal{B}(B^+ \rightarrow K^+ e^+ e^-)}{\mathcal{B}(B^+ \rightarrow K^+ J/\psi(e^+ e^-))}$$



# Experimental status: Lepton universality

Results with LHCb data  $9 \text{ fb}^{-1}$  [arXiv:2103.11769] :

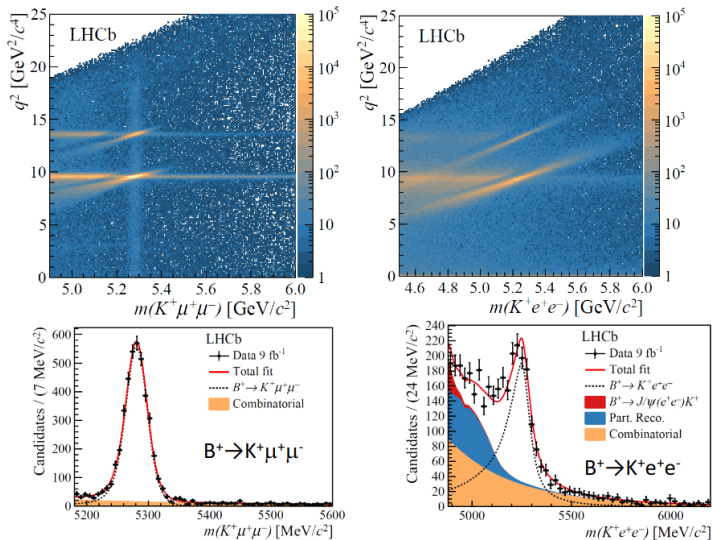

# Experimental status: Lepton universality

Results with LHCb data  $9 \text{ fb}^{-1}$  [arXiv:2103.11769] :

$$R_K = 0.846^{+0.044}_{-0.041}$$

Deviation from SM at  $3.1\sigma$

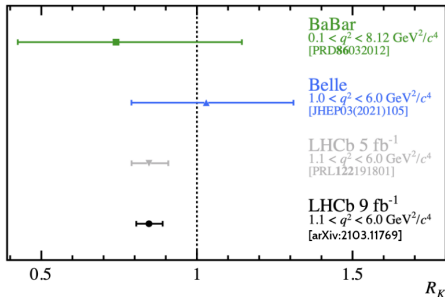

# Experimental status: Lepton universality

Results with LHCb data  $9 \text{ fb}^{-1}$  [arXiv:2103.11769] :

$$R_K = 0.846^{+0.044}_{-0.041}$$

Deviation from SM at  $3.1\sigma$

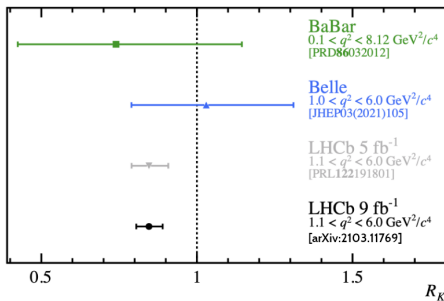

Tension with the SM from observables

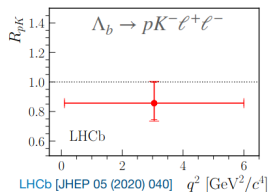
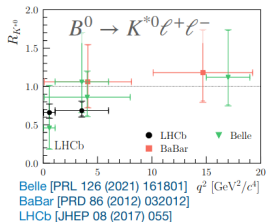

# Experimental status: Lepton universality

Results with LHCb data  $9 \text{ fb}^{-1}$  [arXiv:2103.11769] :

$$R_K = 0.846_{-0.041}^{+0.044}$$

Deviation from SM at  $3.1\sigma$

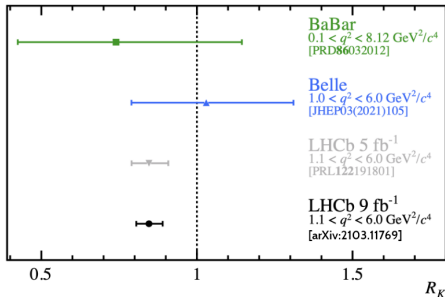

Belle II is entering in the game...

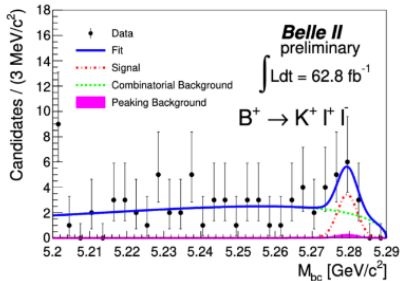

# Experimental status: Global fits

Global fits (more than 100 observables)

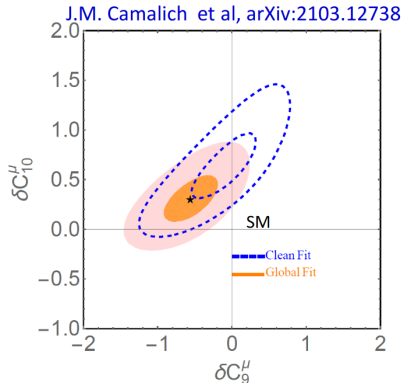
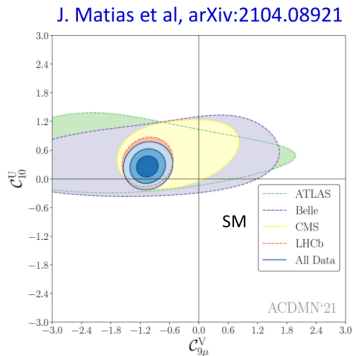

- New Physics hypothesis preferred over SM by more than  $4-5\sigma$
- Main effect on the  $C_{9\mu}$  coefficient



## 1 Introduction

- Theoretical framework
- LHCb Detector
- Experimental status with other rare decays

## 2 Radiative Decays

- Experimental challenges
- Analyses

## 3 Conclusions



# Radiative decays

- Rare decays with a  $b \rightarrow s\gamma$  transition
- Sensitive to  $C_7$  and  $C_7'$  through:
  - Photon polarization:  $\alpha_\gamma^{LO} = \frac{|C_7|^2 - |C_7'|^2}{|C_7|^2 + |C_7'|^2}$
  - Branching ratio:  $\mathcal{B} \propto |C_7|^2 + |C_7'|^2$
  - CP asymmetry:  $A_{CP} \propto \text{Im} \frac{C_7 C_7'}{|C_7|^2 + |C_7'|^2}$

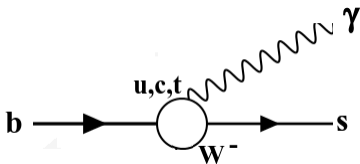

How to access **the photon polarization** in  $b$ -hadron decays?

- **Time dependent analyses, using  $B$ - $\bar{B}$  interference of mixing and decay:**

- Final common state for neutral  $B$  and  $\bar{B}$ :  $B_{(s)} \rightarrow V\gamma$ ,  $V \rightarrow KK, \pi\pi$
- $B_s$  more profitable ( $\Delta\Gamma_s \gg \Delta\Gamma_d$ )
- @ LHCb:  $V$  to charged tracks, better no  $\pi^0$ 's, no  $K_s$ 's (Ex:  ~~$B_d \rightarrow K^{*0}(K_s\pi^0)\gamma$~~ )
- $B_s \rightarrow \phi\gamma$ ,  $B_d \rightarrow \rho\gamma$ ,  $B_d \rightarrow \omega\gamma$
- Observables: time dependent decay widths, CP asymmetries
- Need the use of flavour tagging, which reduces a lot the statistics ( $\varepsilon_{\text{eff}} \sim 5\%$ )

- **Angular analyses:**

- $B_{(s)}$  to three-body +  $\gamma$  decays ( $B^+ \rightarrow K^+\pi^+\pi^+\gamma$ )
- Decays of  $b$ -baryons ( $\Lambda_b \rightarrow \Lambda\gamma \dots$ )
- Decays with an electron pair in the final state  $\gamma \rightarrow e^-e^+$ 
  - with  $\gamma$  real: radiative decays with converted photons ( $B_{(s)} \rightarrow V\gamma(\rightarrow e^-e^+)$ )
  - or virtual:  $B \rightarrow K^*e^+e^-$  analyzed in the low  $q^2$  region



## Radiative b-baryon decays:

- Non-zero spin grants access to more observables
- Two spectator quarks  $\implies$  different form factors
- Photon polarization has never been measured!!
- $b$ -baryons only at accesible  $pp$  colliders (LHC)

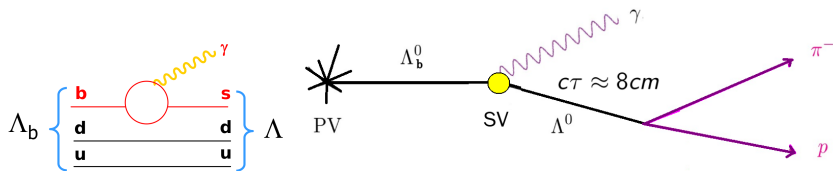

# Experimental challenges

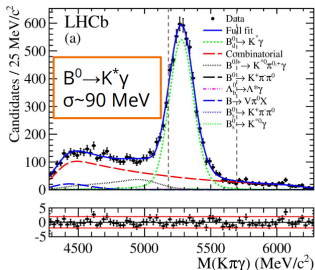

[Nucl.Phys.B867(2013)1]

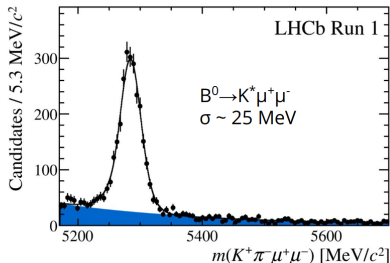

[PRL125(2020)011802]

Challenges for analysis involving neutrals ( $\gamma$  and  $\pi^0$ ):

- Photon direction not reconstructed:
  - Mass resolution dominated by photon momentum
  - Large background ( $\sim 10 \gamma$ /events, merge  $\pi^0 \rightarrow \gamma\gamma$ )
- Rare decays  $\implies$  low signal yield ( $\mathcal{B} \sim O(10^{-5})$ )



# Experimental challenges

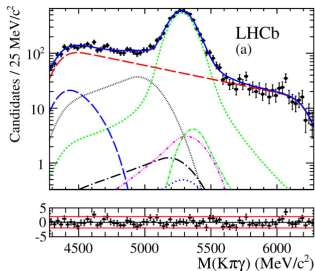

[Nucl.Phys.B867(2013)1]

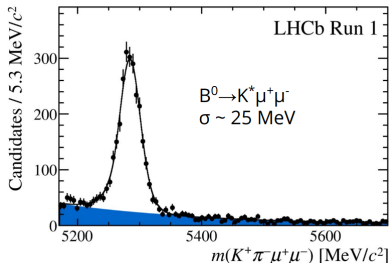

[PRL125(2020)011802]

Challenges for analysis involving neutrals ( $\gamma$  and  $\pi^0$ ):

- Photon direction not reconstructed:
  - Mass resolution dominated by photon momentum
  - Large background ( $\sim 10 \gamma/\text{events}$ , merge  $\pi^0 \rightarrow \gamma\gamma$ )
- Rare decays  $\implies$  low signal yield ( $\mathcal{B} \sim O(10^{-5})$ )



# Experimental challenges

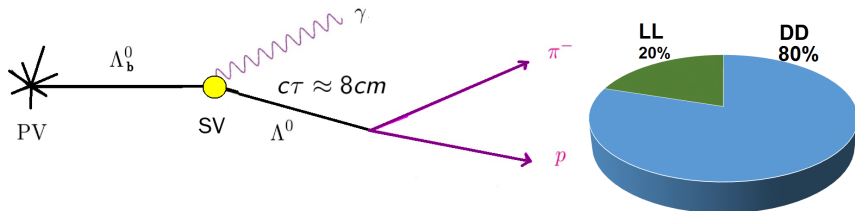

Challenges for analysis involving neutrals ( $\gamma$  and  $\pi^0$ ):

- Photon direction not reconstructed:
  - Mass resolution dominated by photon momentum
  - Large background ( $\sim 10\gamma/\text{events}$ , merge  $\pi^0 \rightarrow \gamma\gamma$ )
- Rare decays  $\implies$  low signal yield ( $\mathcal{B} \sim O(10^{-5})$ )
- Decays involving long-lived particles ( $K_S, \Lambda^0, \Xi^-$ )
  - Decay after the VELO
    - Worse IP/vertex position resolution
    - Trigger only selects Long tracks
  - SV position cannot determined reconstructed



# Experimental challenges

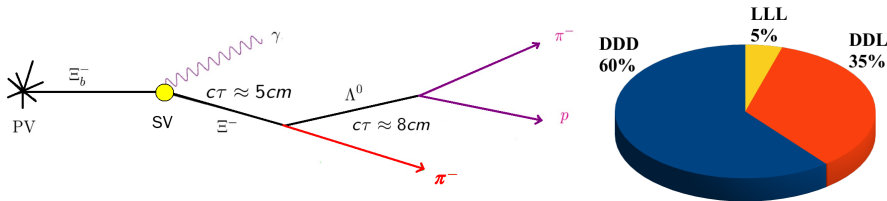

Challenges for analysis involving neutrals ( $\gamma$  and  $\pi^0$ ):

- Photon direction not reconstructed:
  - Mass resolution dominated by photon momentum
  - Large background ( $\sim 10 \gamma/\text{events}$ , merge  $\pi^0 \rightarrow \gamma\gamma$ )
- Rare decays  $\implies$  low signal yield ( $\mathcal{B} \sim O(10^{-5})$ )
- Decays involving long-lived particles ( $K_S, \Lambda^0, \Xi^-$ )
  - Decay after the VELO
    - Worse IP/vertex position resolution
    - Trigger only selects Long tracks
  - SV position cannot be determined/reconstructed



# Photon polarization in $\Lambda_b^0 \rightarrow \Lambda^0 \gamma$

$\Lambda_b^0 \rightarrow \Lambda^0 \gamma$  decay channel recently observed ( $1.6 \text{ fb}^{-1}$ ) [PRL123(2019)031801]:

- $\mathcal{B}(\Lambda_b^0 \rightarrow \Lambda^0 \gamma) = (7.1 \pm 1.5 \pm 0.6 \pm 0.7) \times 10^{-6}$
- Opens the possibility for direct measurement of photon polarization ( $\alpha_\gamma$ ) in  $b$ -baryon decays

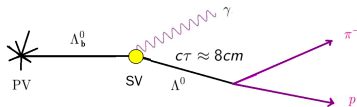
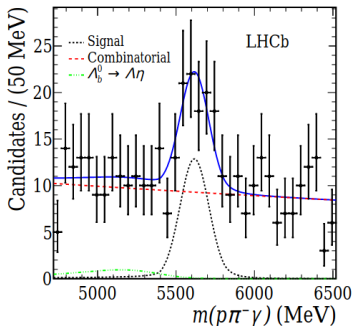

# Photon polarization in $\Lambda_b^0 \rightarrow \Lambda^0 \gamma$

- First angular analysis of radiative b-baryon decays [LHCb-PAPER-2021-03]
- Using  $6\text{fb}^{-1}$  collected by LHCb
- Angular distribution and sensitivity studies computed [EPJC79(2019)634]

$$\Gamma_{\Lambda_b}(\theta_\gamma, \theta_p) = 1 - \alpha_\Lambda P_{\Lambda_b} \cos \theta_p \cos \theta_\gamma - \alpha_\gamma (\alpha_\Lambda \cos \theta_p - P_{\Lambda_b} \cos \theta_\gamma)$$

Integrating in helicity angles:

$$\Gamma_{\Lambda_b}(\theta_\gamma) = \frac{1}{4} \left( 1 - \alpha_\gamma P_{\Lambda_b} \cos \theta_\gamma \right)$$

$$\Gamma_{\Lambda_b}(\theta_p) = \frac{1}{4} \left( 1 - \alpha_\gamma \alpha_\Lambda \cos \theta_p \right)$$

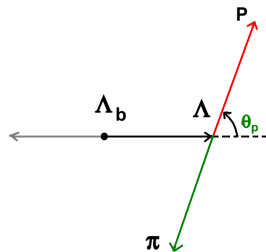

The decay parameters are:

- $P_{\Lambda_b} = 0.00 \pm 0.06(\text{stat}) \pm 0.06(\text{sys})$  [CMS: PRD97(2018)072010]
- $\alpha_\Lambda = 0.754 \pm 0.004$  [BESIII: NP15(2019)631-634]



# Photon polarization in $\Lambda_b^0 \rightarrow \Lambda^0 \gamma$

- First angular analysis of radiative b-baryon decays [LHCb-PAPER-2021-03]
- Using  $6\text{fb}^{-1}$  collected by LHCb
- Angular distribution and sensitivity studies computed [EPJC79(2019)634]

$$\Gamma_{\Lambda_b}(\theta_\gamma, \theta_p) = 1 - \alpha_\Lambda P_{\Lambda_b} \cos \theta_p \cos \theta_\gamma - \alpha_\gamma (\alpha_\Lambda \cos \theta_p - P_{\Lambda_b} \cos \theta_\gamma)$$

Integrating in helicity angles:

$$\Gamma_{\Lambda_b}(\theta_\gamma) = \frac{1}{4} (1 - \alpha_\gamma P_{\Lambda_b} \cos \theta_\gamma)$$

$$\Gamma_{\Lambda_b}(\theta_p) = \frac{1}{4} (1 - \alpha_\gamma \alpha_\Lambda \cos \theta_p)$$

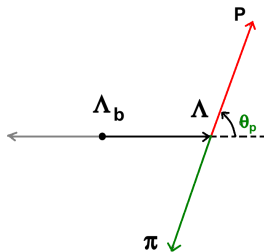

The decay parameters are:

- $P_{\Lambda_b} = 0.00 \pm 0.06(\text{stat}) \pm 0.06(\text{sys})$  [CMS: PRD97(2018)072010]
- $\alpha_\Lambda = 0.754 \pm 0.004$  [BESIII: NP15(2019)631-634]



# Photon polarization in $\Lambda_b^0 \rightarrow \Lambda^0 \gamma$

Using events in the signal region:  $N_{\Lambda_b^0 \rightarrow \Lambda^0 \gamma} = 440 \pm 40$

- Angular fit to  $\cos \theta_p$  in the signal region

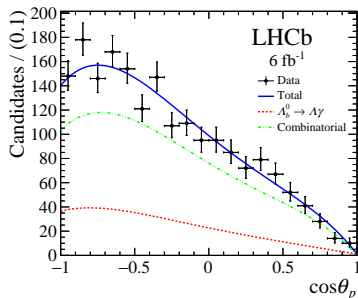
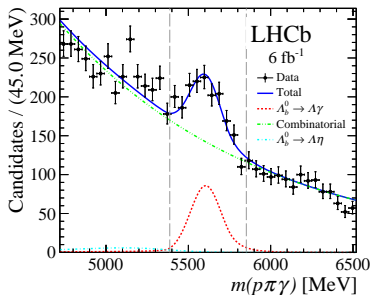

$$\alpha_\gamma = 0.82^{+0.17}_{-0.26} \quad {}^{+0.04}_{-0.13} \quad [\text{LHCb-PAPER-2021-03}]$$

Compatible with the SM prediction ( $\alpha_\gamma = 1$ )



# Photon polarization in $\Lambda_b^0 \rightarrow \Lambda^0 \gamma$

CP test on  $\Lambda_b^0 \rightarrow \Lambda^0 \gamma$  and  $\bar{\Lambda}_b^0 \rightarrow \bar{\Lambda}^0 \gamma$  [LHCb-PAPER-2021-03]

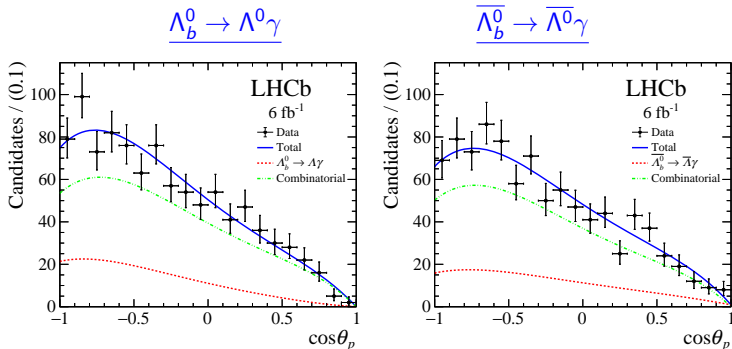

- $\alpha_\gamma^{\Lambda_b^0 \rightarrow \Lambda^0 \gamma} > 0.56(0.44)$  at 90% (95%) CL
- $\alpha_\gamma^{\bar{\Lambda}_b^0 \rightarrow \bar{\Lambda}^0 \gamma} = -0.56_{0.33}^{+0.36} \quad ^{+0.16}_{-0.09}$



# Search for the $\Xi_b^- \rightarrow \Xi^- \gamma$ decay

First search of the  $\Xi_b^- \rightarrow \Xi^-$  decay

- No previous limit:
  - $\mathcal{B}(\Xi_b^- \rightarrow \Xi^-)_{\text{theo}} = (3.03 \pm 0.10) \times 10^{-4}$  [PRD83('11)054007]
  - $\mathcal{B}(\Xi_b^- \rightarrow \Xi^-)_{\text{theo}} = (1.23 \pm 0.64) \times 10^{-5}$  [arXiv:2008.06624]
- Analysis uses  $5.4 \text{ fb}^{-1}$  LHCb data [arXiv:2108.07678]

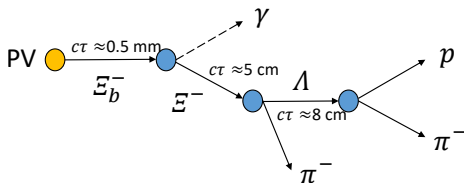

Normalization channel:  $\Xi_b^- \rightarrow \Xi^- J/\psi$



# Search for the $\Xi_b^- \rightarrow \Xi^- \gamma$ decay

Simultaneous mass fit to  $\Xi_b^- \rightarrow \Xi^- \gamma$  and  $\Xi_b^- \rightarrow \Xi^- J/\psi$  [arXiv: 2108.07678]:

$$\Xi_b^- \rightarrow \Xi^- \gamma$$

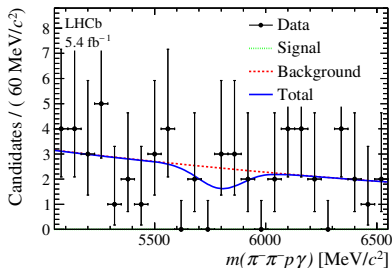

$$\Xi_b^- \rightarrow \Xi^- J/\psi$$

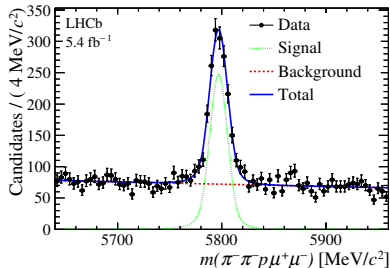

- No  $\Xi_b^- \rightarrow \Xi^- \gamma$  is found



# Search for the $\Xi_b^- \rightarrow \Xi^- \gamma$ decay

First limit of  $\Xi_b^- \rightarrow \Xi^- \gamma$  using Feldman Cousin method [arXiv: 2108.07678]:

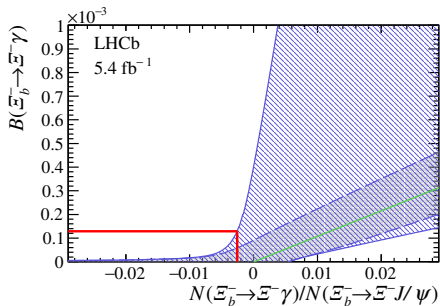

$$\mathcal{B}(\Xi_b^- \rightarrow \Xi^- \gamma) < 1.3(0.6) \times 10^{-4} \text{ at 95\% (90\%) CL}$$

- $\mathcal{B}(\Xi_b^- \rightarrow \Xi^- J/\psi)$  is the main source of uncertainty
- Providing also the limit:  $\frac{\mathcal{B}(\Xi_b^- \rightarrow \Xi^- \gamma)}{\mathcal{B}(\Xi_b^- \rightarrow \Xi^- J/\psi)} < 0.12 (0.08) \text{ at 95\% (90\%) CL}$



# $B \rightarrow K^* ee$ at very low $q^2$

New analysis with  $9 \text{ fb}^{-1}$  LHCb data:

- Decay is dominated by  $b \rightarrow s \gamma$  pole at very low  $q^2$  (0.0008 - 0.257  $\text{GeV}^2$ )
- Relevant angles:  $\theta_\ell$ ,  $\theta_K$ ,  $\tilde{\phi}$
- Angular observables:  $F_L$ ,  $A_T^{\text{Re}}$ ,  $A_T^{(2)}$ ,  $A_T^{\text{Im}}$
- Sensitive to the polarization of the virtual photon

$$A_{R(L)} \equiv A_{R(L)} e^{i\phi_{R(L)}}, \quad \tan \chi \equiv |C'_7/C_7|$$

$$A_T^{(2)} \simeq \sin(2\chi) \cos(\phi_L - \phi_R),$$

$$A_T^{\text{Im}} \simeq \sin(2\chi) \sin(\phi_L - \phi_R),$$

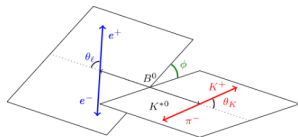

$$\begin{aligned} & \frac{1}{d(\Gamma + \bar{\Gamma})/dq^2} \frac{d^4(\bar{\Gamma} + \bar{\Gamma})}{dq^2 d\cos\theta_\ell d\cos\theta_K d\tilde{\phi}} = \\ & = \frac{9}{16\pi} \left[ \frac{3}{4} (1 - F_L) \sin^2\theta_K + F_L \cos^2\theta_K \right. \\ & \quad + \frac{1}{4} (1 - F_L) \sin^2\theta_K \cos 2\theta_\ell - F_L \cos^2\theta_K \cos 2\theta_\ell \\ & \quad + (1 - F_L) A_T^{\text{Re}} \sin^2\theta_K \cos\theta_\ell \\ & \quad + \frac{1}{2} (1 - F_L) A_T^{(2)} \sin^2\theta_K \sin^2\theta_\ell \cos 2\tilde{\phi} \\ & \quad \left. + \frac{1}{2} (1 - F_L) A_T^{\text{Im}} \sin^2\theta_K \sin^2\theta_\ell \sin 2\tilde{\phi} \right] \end{aligned}$$



# $B \rightarrow K^* e e$ at very low $q^2$

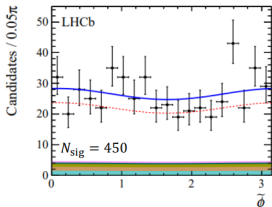
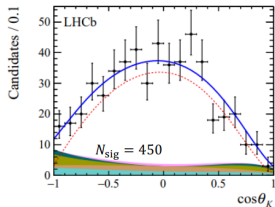
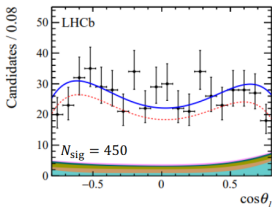
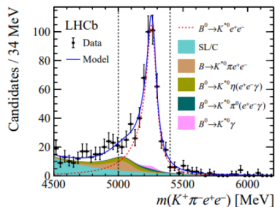

$$F_L = 0.044 \pm 0.026 \pm 0.014,$$

$$A_T^{\text{Re}} = -0.06 \pm 0.08 \pm 0.02,$$

$$A_T^{(2)} = +0.11 \pm 0.10 \pm 0.02,$$

$$A_T^{\text{Im}} = +0.02 \pm 0.10 \pm 0.01,$$

Uncertainty statistically dominated.

$A_T^{(2)}$  and  $A_T^{\text{Im}}$  results dominate the sensitivity to Re & Im of  $C_7^{(l)}$



# NP Constraints

Constraints to  $C_7'$  from radiative decays

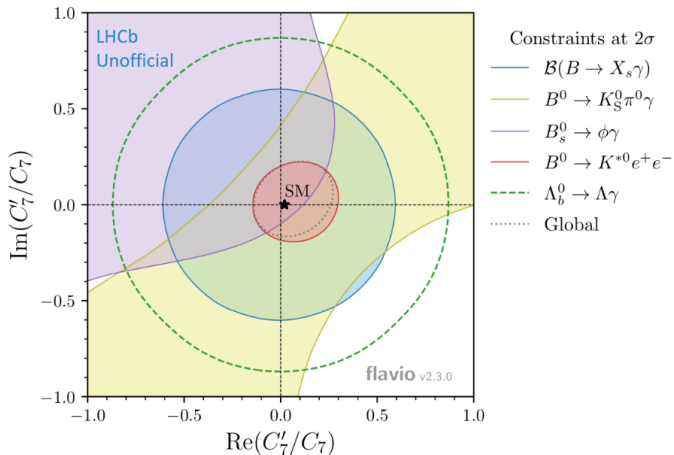

Results presented are statistically dominated



# Prospects: Converted photons

Most of radiative analyses use calorimetric photons

- Converted to a  $e^+e^-$  pair after the magnet or unconverted

It is also possible to use converted photons ( $\gamma \rightarrow e^+e^-$ ):

- $e^+e^-$  track can be reconstructed  $\implies$  B mass resolution 3 times better
  - Allow to access  $|V_{td}/V_{ts}|$  suppressed modes like  $B_s \rightarrow K^*\gamma$
- Grant access to SV in decays involving long-lived particles
- Its rate is 20 times lower than for calo photons
- More analyses with converted photons will become feasible with more data

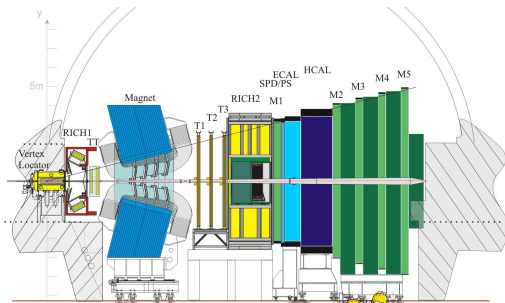
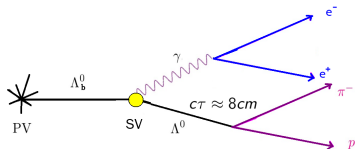

## 1 Introduction

- Theoretical framework
- LHCb Detector
- Experimental status with other rare decays

## 2 Radiative Decays

- Experimental challenges
- Analyses

## 3 Conclusions



# The future

2020	2021	2022	2023	2024	2025	2026	2027	2028	2029	2030	2031	2032	2033	203+
		Run III						Run IV					Run V	
<b>LS2</b>					<b>LS3</b>						<b>LS4</b>			
<b>LHCb 40 MHz UPGRADE I</b>		$L = 2 \times 10^{33}$			<b>LHCb Consolidate: UPGRADE Ib</b>			$L = 2 \times 10^{33}$ $50 \text{ fb}^{-1}$			<b>LHCb UPGRADE II</b>		$L = 1-2 \times 10^{34}$ $300 \text{ fb}^{-1}$	
<b>ATLAS Phase I Upgr</b>		$L = 2 \times 10^{34}$			<b>ATLAS Phase II UPGRADE</b>			<b>HL-LHC</b> $L = 5 \times 10^{34}$					<b>HL-LHC</b> $L = 5 \times 10^{34}$	
<b>CMS Phase I Upgr</b>		$300 \text{ fb}^{-1}$			<b>CMS Phase II UPGRADE</b>								$3000 \text{ fb}^{-1}$	
<b>Belle II</b>		$5 \text{ ab}^{-1}$			$L = 6 \times 10^{35}$			$50 \text{ ab}^{-1}$						



- ▶ New detector
- ▶ Full software trigger (30MHz)
- ▶ Event reconstruction on GPU cards
- ▶ + Turbo dedicated trigger scheme
- ▶ Installation and commissioning ongoing

▶ Analysis of Belle II with  $5 \text{ ab}^{-1}$  will start to be competitive with LHCb



# Conclusions

- Rare decays are excellent probes of NP
  - They are extensively studied at LHCb
  - Multiple tension w.r.t. SM in  $b \rightarrow (s)ll$  transitions
- 
- LHCb is undergoing a major upgrade
  - Expect more precise results with:
    - More luminosity
    - Less systematic uncertainties

Stay Tuned  
FOR something  
AWESOME



# Thanks for your attention



# LHCb detector

- One of the four detector at LHC
- LHCb is a single-arm ( $2 < \eta < 5$ ) spectrometer

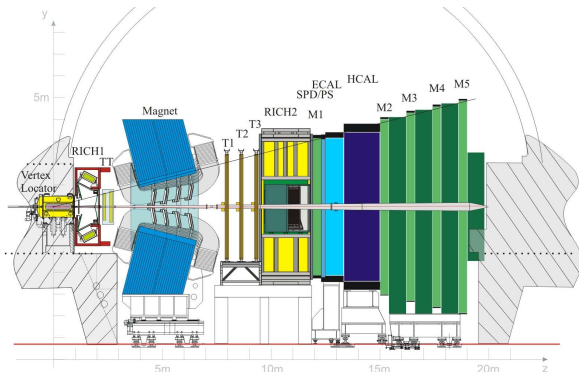

$$\eta = -\ln \left[ \tan \left( \frac{\theta}{2} \right) \right]$$

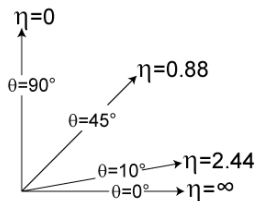

$\theta$ : Angle between  $\mathbf{p}$  and positive beam axis.



# LHCb detector

- One of the four detectors at LHC
- LHCb is a single-arm ( $2 < \eta < 5$ ) spectrometer
- Optimised for beauty and charm decays

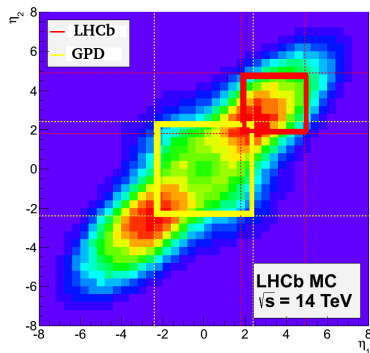
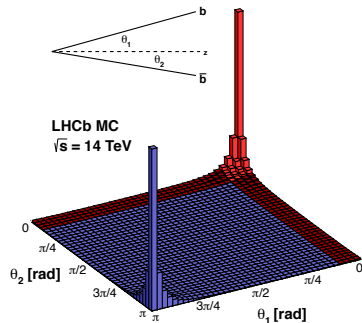

# LHCb Detector

Integrated Luminosity:

- Run I (2011-2012):  $3 \text{ fb}^{-1}$
- Run II (2015-2018):  $6 \text{ fb}^{-1}$

$1 \text{ fb}^{-1} \approx 10^{12}$  pp collisions

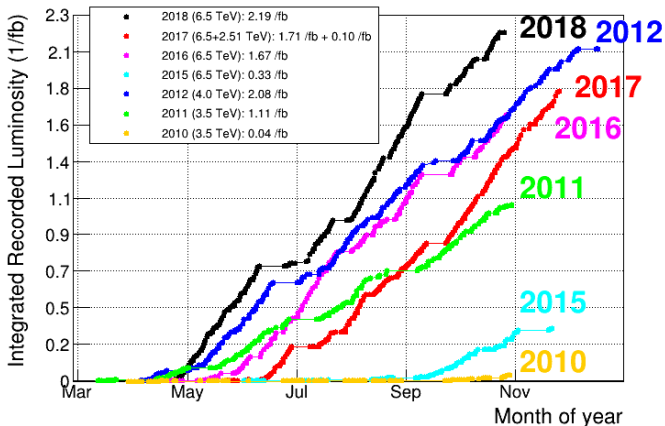

# Search for $\Lambda_b^0 \rightarrow \Lambda^0 \gamma$ decay

- Reconstruction is very challenging: no  $\Lambda_b^0$  vertex
  - No direction from  $\gamma$  cluster
  - $\Lambda$  is a long-lived particle (LLP)  $\implies \Lambda_b^0$  vertex  $\neq \Lambda$  vertex

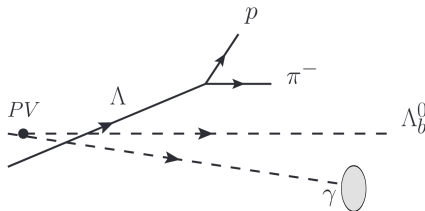

- SM prediction:  $\mathcal{B}(\Lambda_b^0 \rightarrow \Lambda^0 \gamma) = 10^{-7} - 10^{-5}$



# Search for $\Lambda_b^0 \rightarrow \Lambda^0 \gamma$ decay

First observation of  $\Lambda_b^0 \rightarrow \Lambda^0 \gamma$  using 2016 data ( $1.7 \text{ fb}^{-1}$ )

[LHCb: arXiv:1904.06697]

- Signal excess of  $5.6 \sigma$  significance

Signal:  $\Lambda_b^0 \rightarrow \Lambda^0 \gamma$

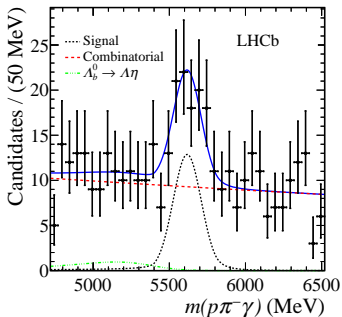

Control:  $B \rightarrow K^* \gamma$

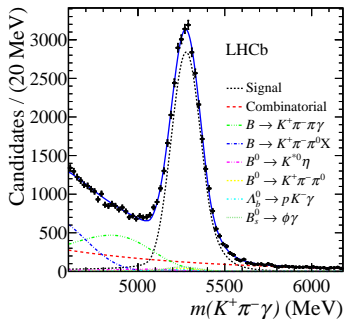

$$\mathcal{B}(\Lambda_b^0 \rightarrow \Lambda^0 \gamma) = (7.1 \pm 1.5_{\text{stat}} \pm 0.7_{\text{syst}} \pm 0.6_{f_{\Lambda_b^0}/f_{B^0}}) \times 10^{-6}$$



# Time-dependent analysis of $B_s \rightarrow \phi\gamma$

## Main systematics:

	Uncertainty source	$\sigma(\mathcal{A}^\Delta)$	$\sigma(S)$	$\sigma(C)$
Statistical	Fit outcome	+0.347 -0.379	0.264	0.250
External measurements	$(\Gamma_s, \Delta\Gamma_s)$	0.086	0	0
	$\Gamma_d$	0.043	0	0
	$\Delta m_s$	0	0.008	0.013
Decay time	Acceptance: MC limited statistics	0.082	0	0
	Acceptance: modelling	0.028	0	0
	Resolution: MC limited statistics	0	0.001	0.002
	Resolution: modelling	0	0.096	0.075
Toy studies	Limited statistics	0.011	0.011	0.011
Mistag probability	OS tagger calibration	0	0.010	0.010
	SS tagger calibration	0	0.049	0.031
Background subtraction	Mass modelling: signal	< 0.01	< 0.01	< 0.01
	Mass modelling: combinatorial	0.034	< 0.01	< 0.01
	Mass modelling: partial	0.081	0.010	0.020
	Peaking backgrounds	0.036	0.018	0.030
	Mass-time correlation	0.110	< 0.01	< 0.01
<b>Total</b>	$\sigma_{\text{stat.}}$	+0.347 -0.379	0.264	0.250
	$\sigma_{\text{ext.}}$	0.096	0.008	0.013
	$\sigma_{\text{sys.}}$	0.170	0.111	0.109



# Search for $\Lambda_b^0 \rightarrow \Lambda^0 \gamma$ decay

Analysis statistically limited. Main systematics:

Source	Uncertainty (%)
Data/simulation agreement	7.7
$\Lambda_b^0$ fit model	3.0
$B^0 \rightarrow K^{*0} \gamma$ backgrounds	2.7
Size of simulated samples	1.7
Efficiency ratio	0.7
Sum in quadrature	8.9
$f_{\Lambda_b^0}/f_{B^0}$	8.7
Input branching fractions	3.0
Sum in quadrature	9.2

from external measurements



# Helicity angles for $\Lambda_b^0 \rightarrow \Lambda^0 \gamma$ decay

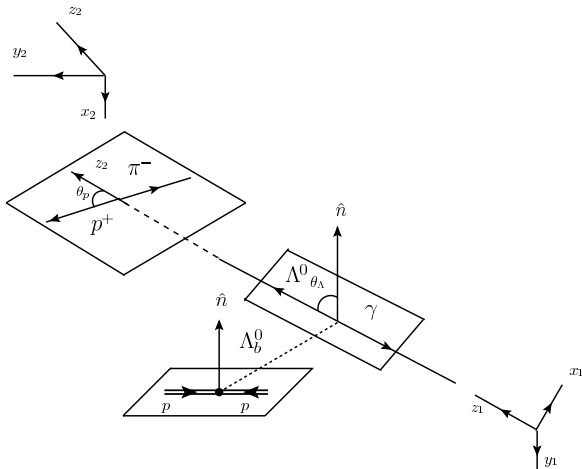

# Helicity angles for $\Xi_b^- \rightarrow \Xi^- \gamma$ decay

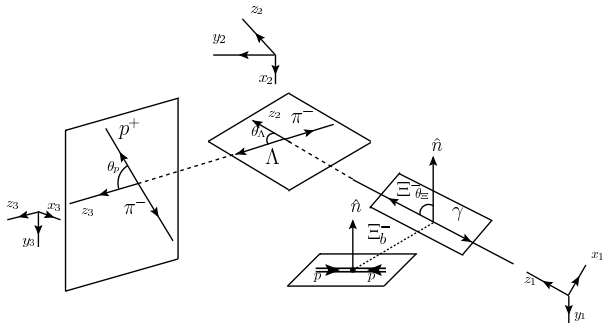

# Experimental status

Deviations in several decay channels with a  $b \rightarrow s(d)ll$  transition (see ???'s talk):

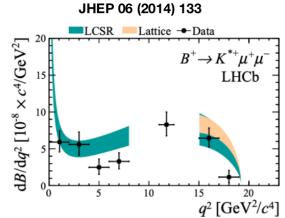
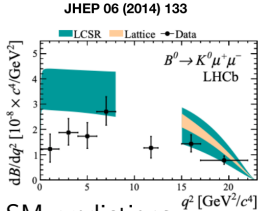
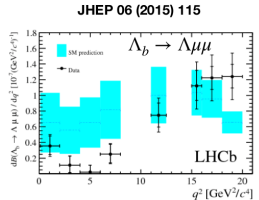
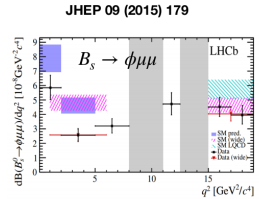
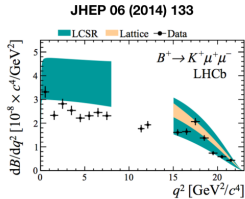
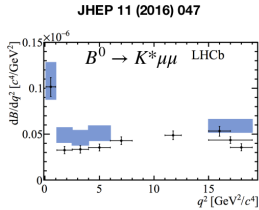

- Data consistently below SM predictions
- Large theory uncertainty due to form factors

