



# *Search for Neutral MSSM Higgs in the $\tau\tau$ decay channel at CDF*

Cristobal Cuenca Almenar



Valencia TileCal meeting, 08/27/2007, IFIC

# Outline

- Brief introduction to the MSSM Higgs sector
- Reconstruction of taus at CDF
- Search strategy and results
- Conclusions

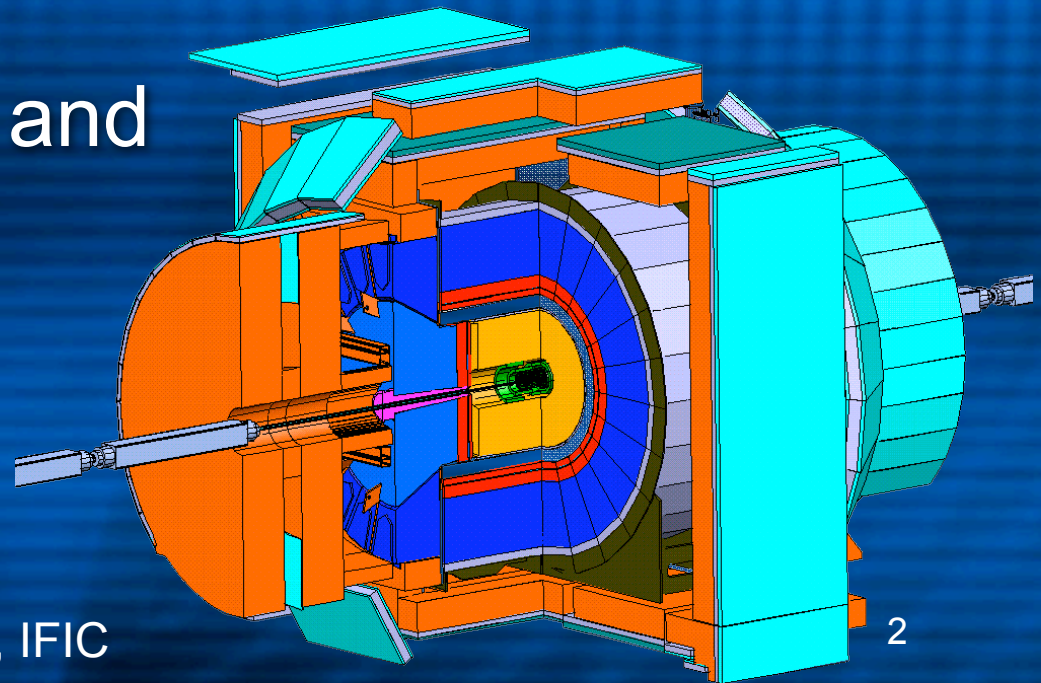

# MSSM Higgs bosons

- MSSM is a SUSY model with 2 Higgs doublets
- 5 Higgs bosons:  $h$ ,  $H$ ,  $A$ ,  $H^+$  and  $H^-$
- 2 parameters,  $M_A$  and  $\tan\beta$ , describe the MSSM Higgs sector (at tree level)

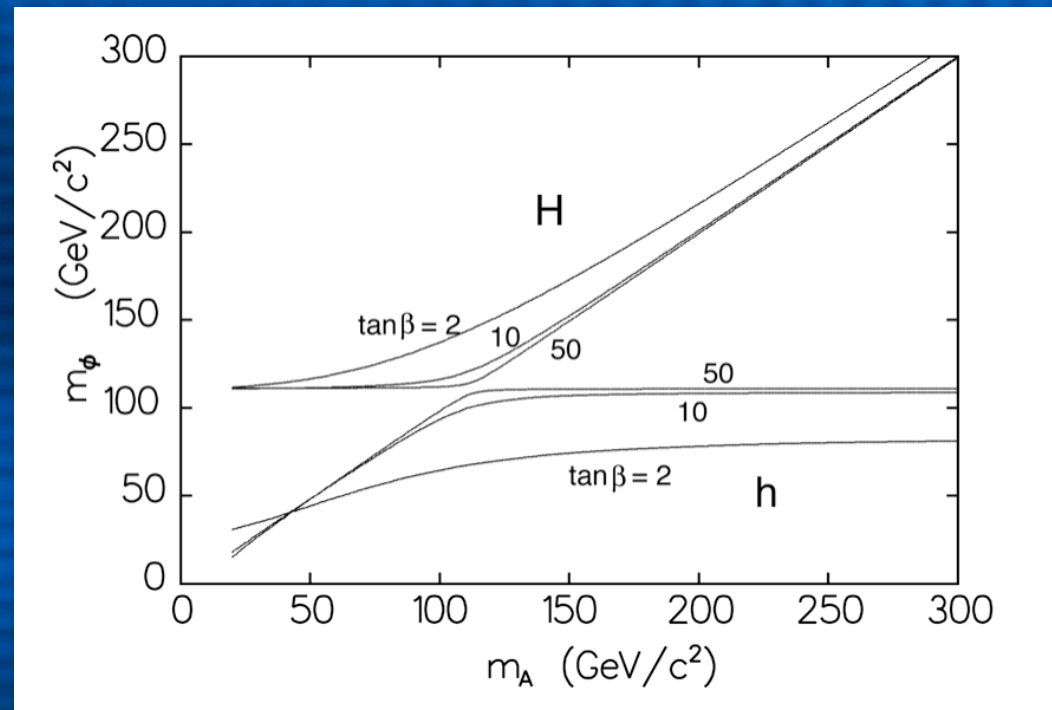

# Neutral MSSM Higgs production

- Production cross section enhanced by  $\sim \tan^2\beta$  with respect to SM Higgs
- Two main processes:

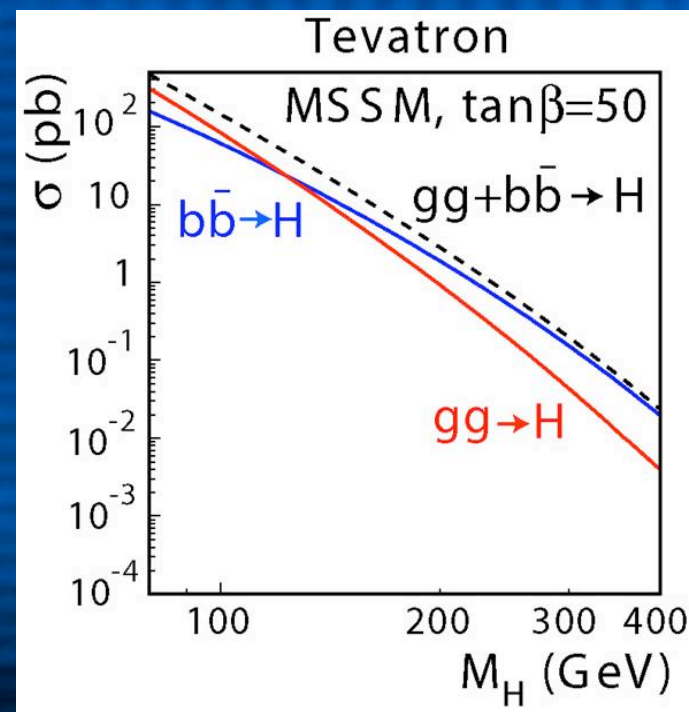
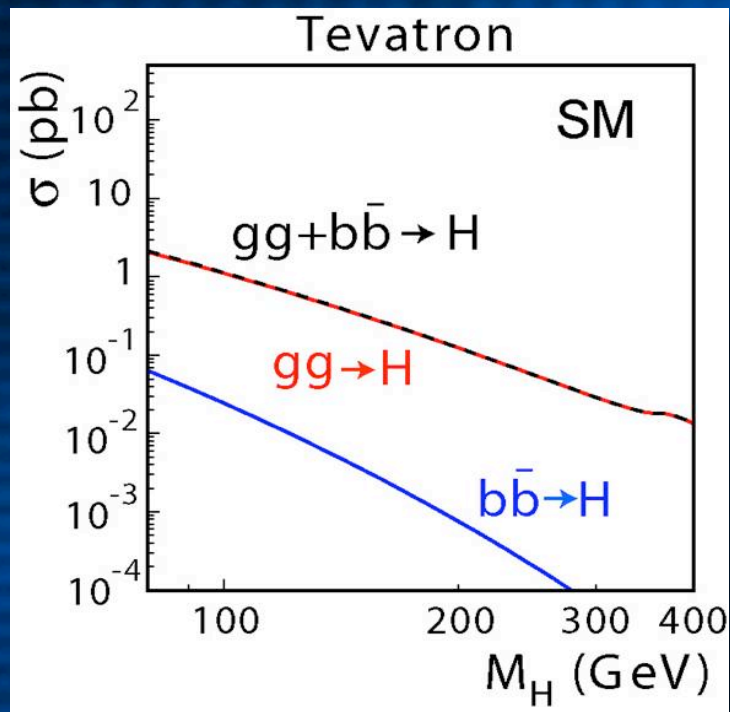
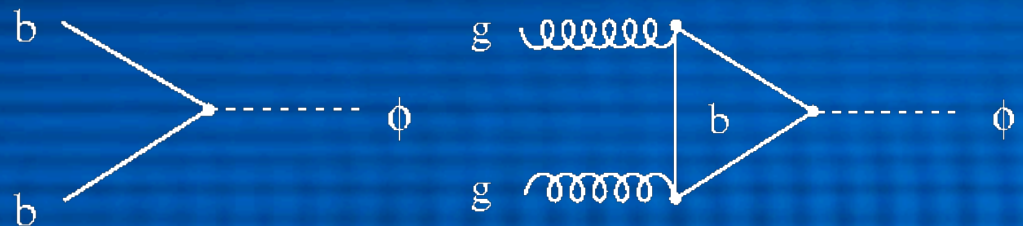

# MSSM Higgs: $\tau^+\tau^-$ decay channels

- Branching ratios of MSSM Higgs ( $\sim$ constant with  $m(A)$  and  $\tan\beta$ )
  - $bb$ :  $\sim 90\%$
  - $\tau^+\tau^-$ :  $\sim 8\%$
- Despite having a smaller BR, the  $\tau^+\tau^-$  signal is cleaner and can probe both main production mechanisms.

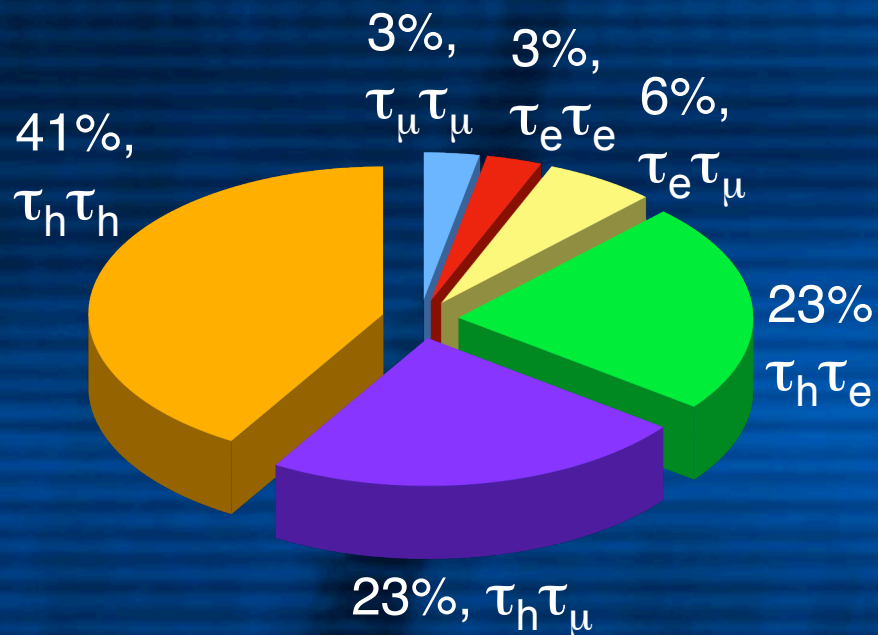

Rich decay spectrum of  $\tau$ :

Leptonic:  $\tau \rightarrow l\nu_\ell\nu_\tau$ , with  $l$  being an electron or a muon (35%)

Hadronic:  $\tau \rightarrow X_h\nu_\tau$ , with  $X_h$  being a set of hadrons (65%).

For this search we focused on  $\tau_h\tau_e$ ,  $\tau_h\tau_\mu$  and  $\tau_e\tau_\mu$

# Hadronic tau reconstruction

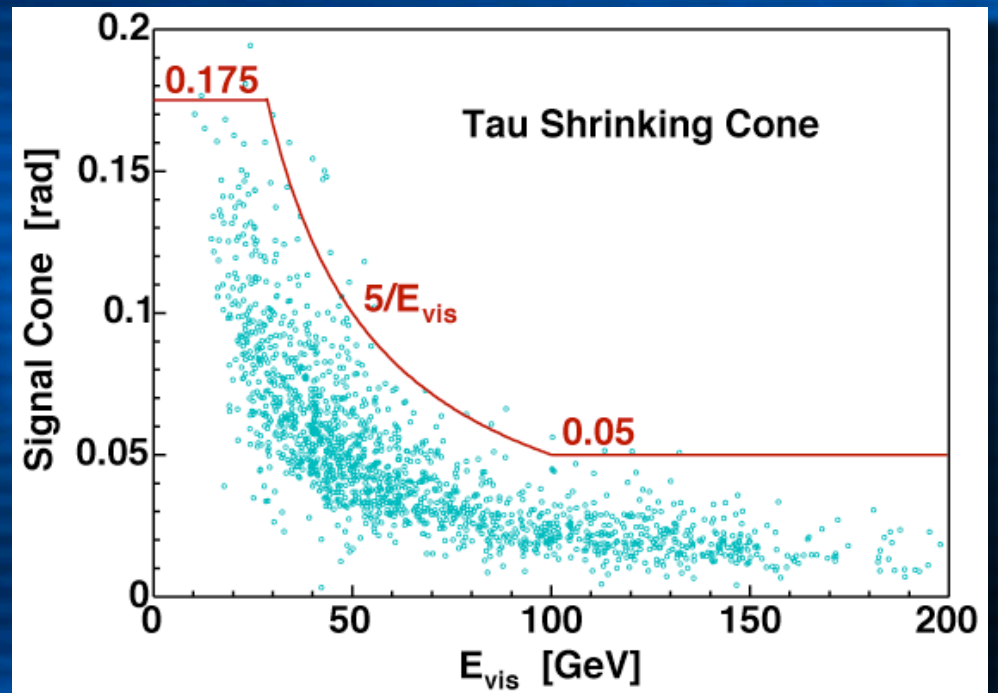
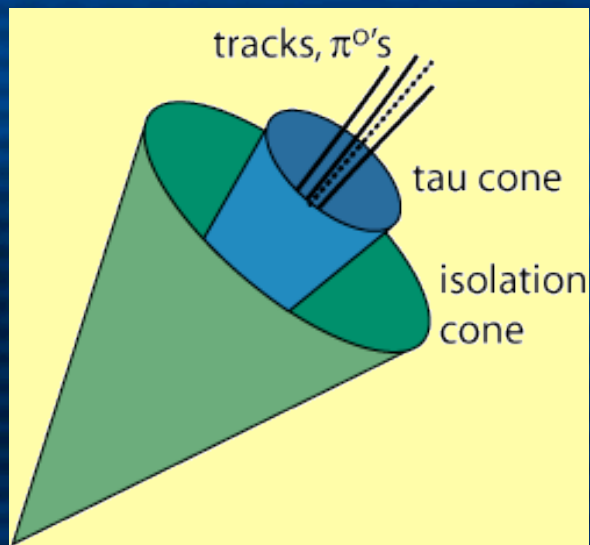

- Match

- a seed track ( $p_T > 6 \text{ GeV}$ ) to
- a narrow “jet” ( $< 1/3$  of cone 0.4)

Define a  
(shrinking) signal cone  
Isolation annulus

# *$\tau$ reconstruction Efficiency and Fake Rates*

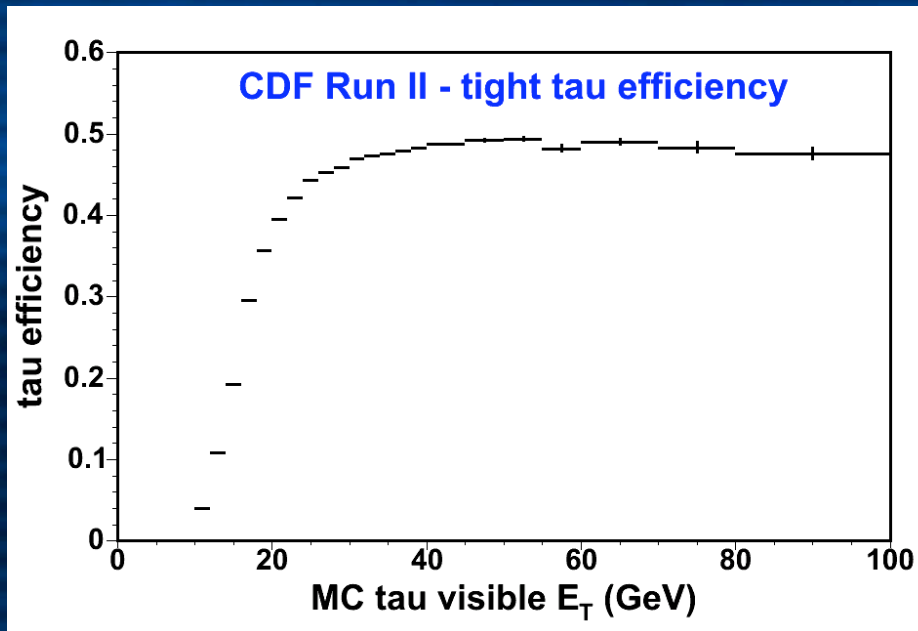

- Jet to tight tau fake rate
- Jet samples used
- QCD (jet) background is estimated from fakes

- Tau reconstruction efficiency
- Estimated from MC

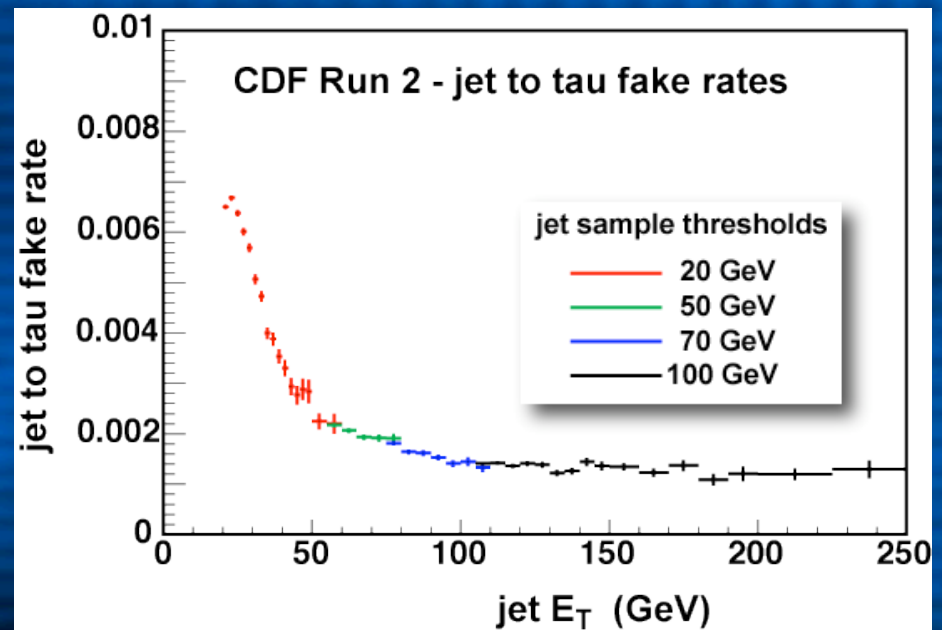

# Event selection: $\tau_\ell + \tau_h / \tau_\ell$

- Total branching ratio of  $\tau_\ell + \tau_h / \tau_\ell$ : 50 %
- We require 1 (2) tight lepton (and 1 tight hadronic tau)
- Extra event level cuts to suppress QCD and  $W \rightarrow \ell + \text{jet}(s)$  backgrounds.

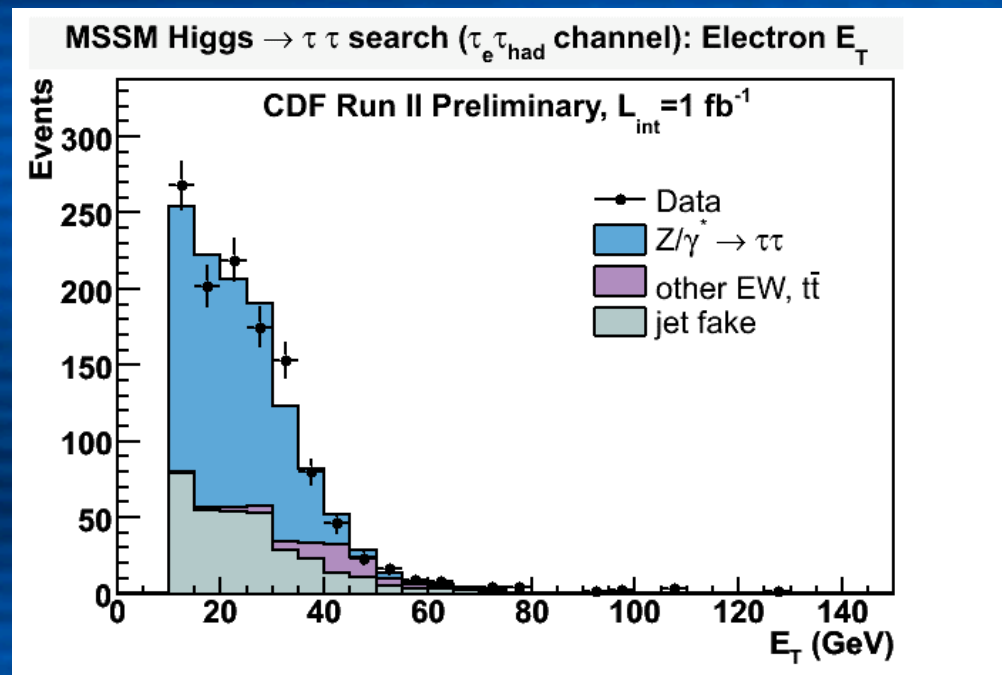

Main backgrounds:

$Z \rightarrow \tau\tau$

QCD (fakes)

# Count & Fit

	$\tau_e \tau_h$	$\tau_\mu \tau_h$	$\tau_e \tau_\mu$
Expected	$1196 \pm 19$	$1001 \pm 13$	$369 \pm 4$
Observed	1215	1000	374

Compare the number expected background and observed events.  
(systematic errors not included)

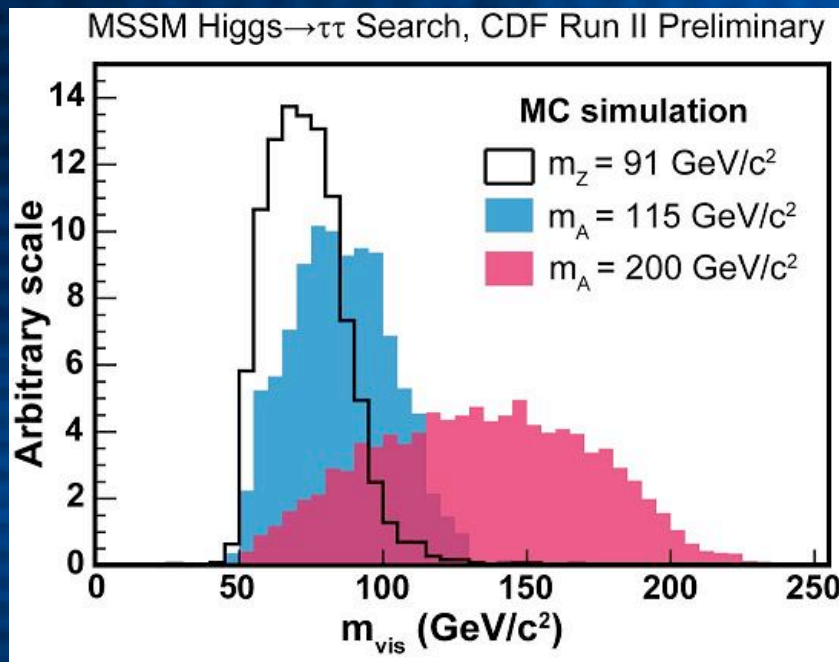

- Take advantage of shapes  
:: Fit ::
- Profile likelihood as a function of the signal cross section.
- Then, we find 95% CL points

# Fit & Limits

- We fit  $M_{\text{vis}}$  (mass of the “visible” products of the Higgs)

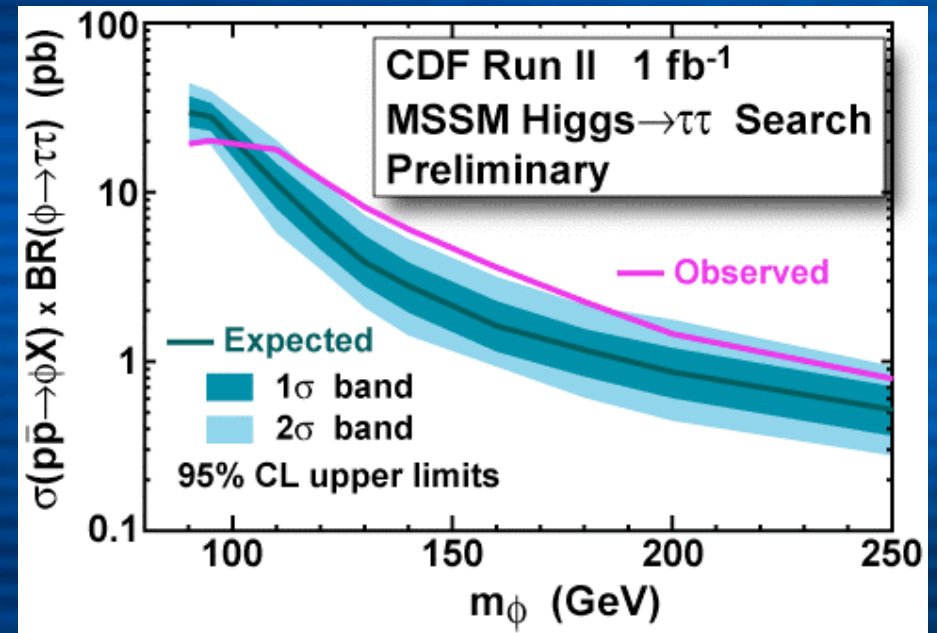

95% CL limit on the cross section × branching ratio

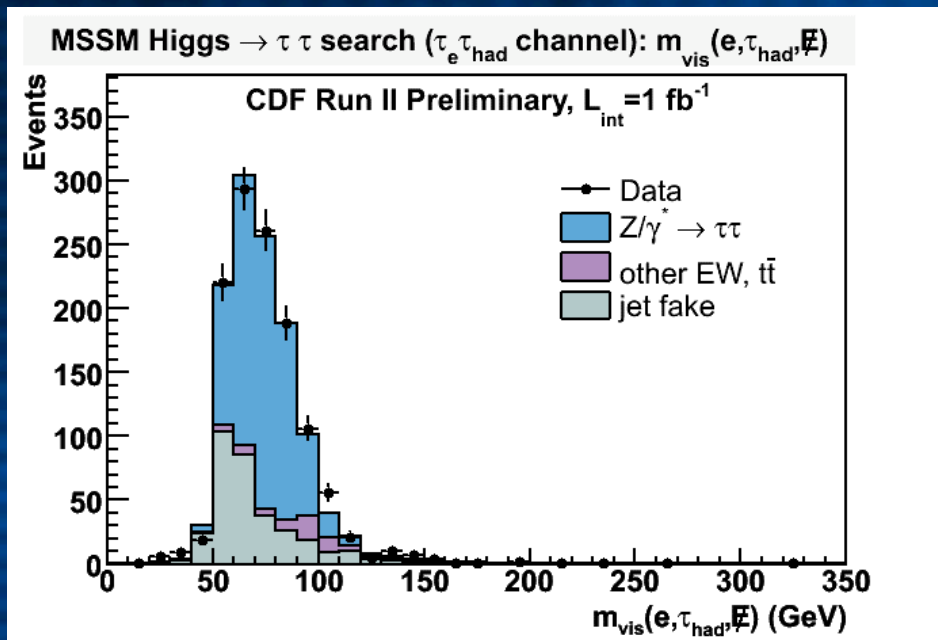

# Interpretation in MSSM

- Four different scenarios

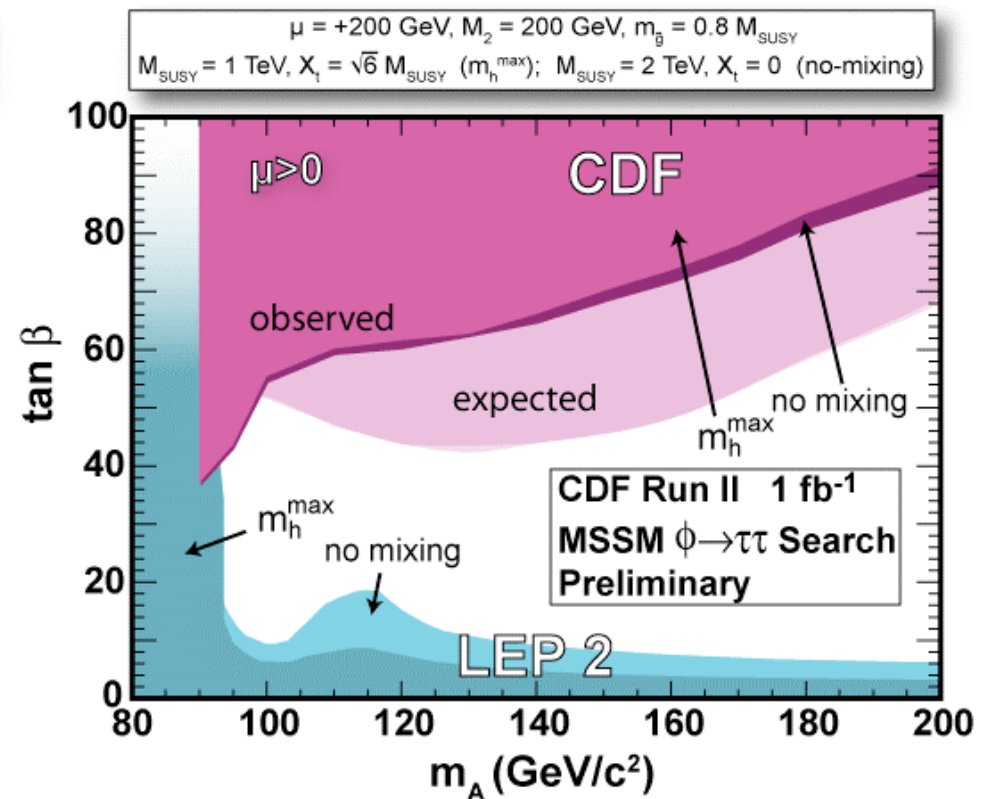
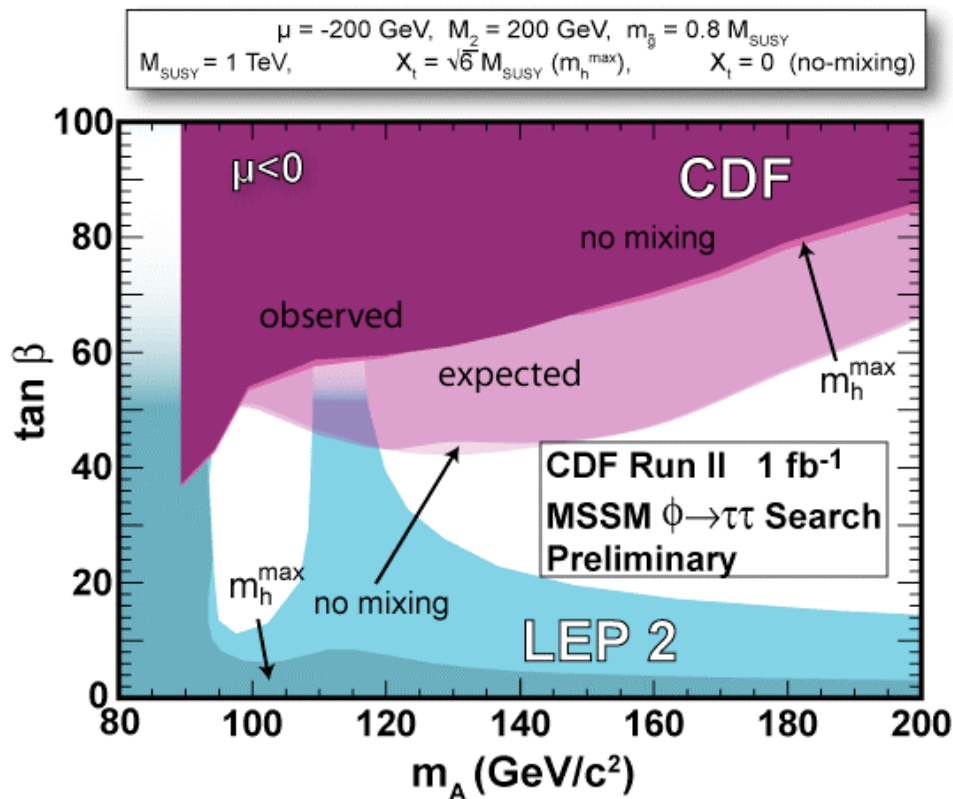

# Why is observed worse than expected?

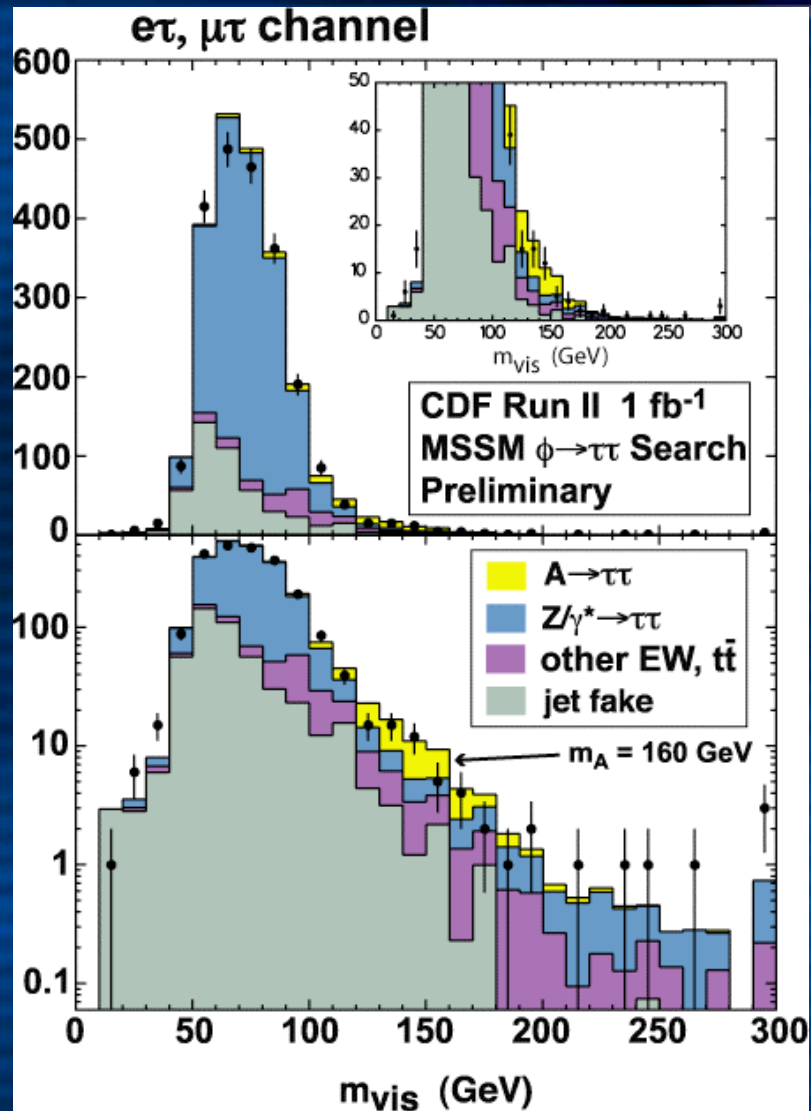

- When fitting data, a small disagreement in the tail pulls the observed limit up
- The fit prefers a *small* signal contribution, with  $m(A) \sim 150$  GeV,  $\sigma \times \text{BR} \sim 2.5$  pb and significance  $< 2\sigma$

# Conclusions and future plan

- Some data excess was found in the high mass tail.
- We are in the process of getting a new result:

- Split exclusive channel:

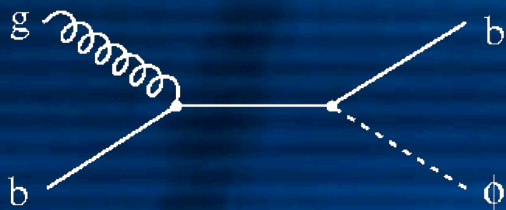

- Reconstruct full mass

- Updated results for the summer !!!!!

