



Searches for New Physics in the Top Quark Samples at CDF

15th International Conference on Supersymmetry and
the Unification of Fundamental Interactions
Parallel session: “ALTERNATIVES”

Susana Cabrera
IFIC (CSIC - University of Valencia)



On behalf of the
CDF Collaboration

MOTIVATION



Top is MASSIVE $M_{TOP} = 170.9 \pm 1.8 \text{ GeV}/c^2$ (TEWG hep-ex/0703034)

Decays before hadronization $\Gamma_t = 1.4 \text{ GeV} \Rightarrow \frac{\hbar}{\Gamma_t} \approx 5 \times 10^{-25} \text{ s} \ll \frac{\hbar}{\Lambda_{QCD}} \approx 3 \times 10^{-24} \text{ s}$
 → Spin information transferred to decay products

Special role in EWSB?

- Top Yukawa coupling to Higgs is “natural” (~ 1)
- M_{top} together with M_W constrains M_{Higgs}

New physics in the top quark samples ?

Searches in the decay: }
 Top charge.
 FCNC $t \rightarrow Zq$
 W helicity

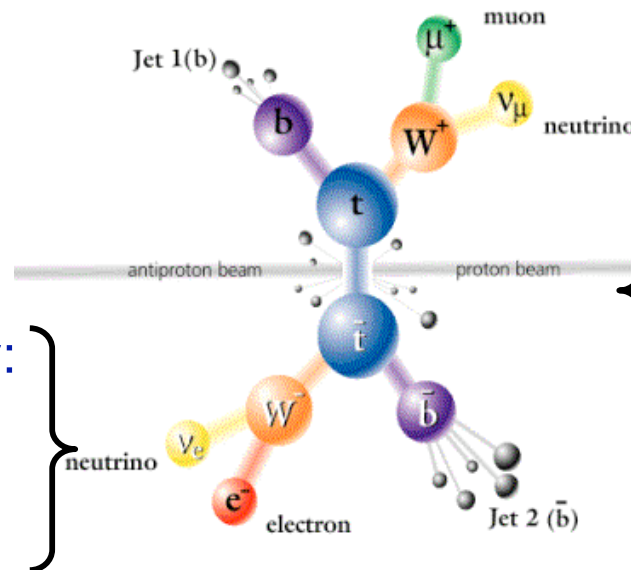

Searches in the production:
 $\sigma_{tt}, \sigma(gg \rightarrow tt)/\sigma(qq \rightarrow tt)$
 $Z' \rightarrow tt$
 $t' \rightarrow Wb$

THE EXPERIMENTAL SETUP



- The CDF II detector:
 - Excellent tracking system:
 - Drift chamber: Central Outer Tracker.
 - Inner silicon detector: → essential for b-tagging and vertexing.
 - EM and HAD calorimeters.
 - MUON systems.
- TEVATRON RUN II:
 - Proton-Antiproton Synchrotron
 - $\sqrt{s} = 1.96$ TeV
 - Aim for 6-8 fb⁻¹ by 2009.
 - Searches for new physics in ~ 1 fb⁻¹ top quark samples

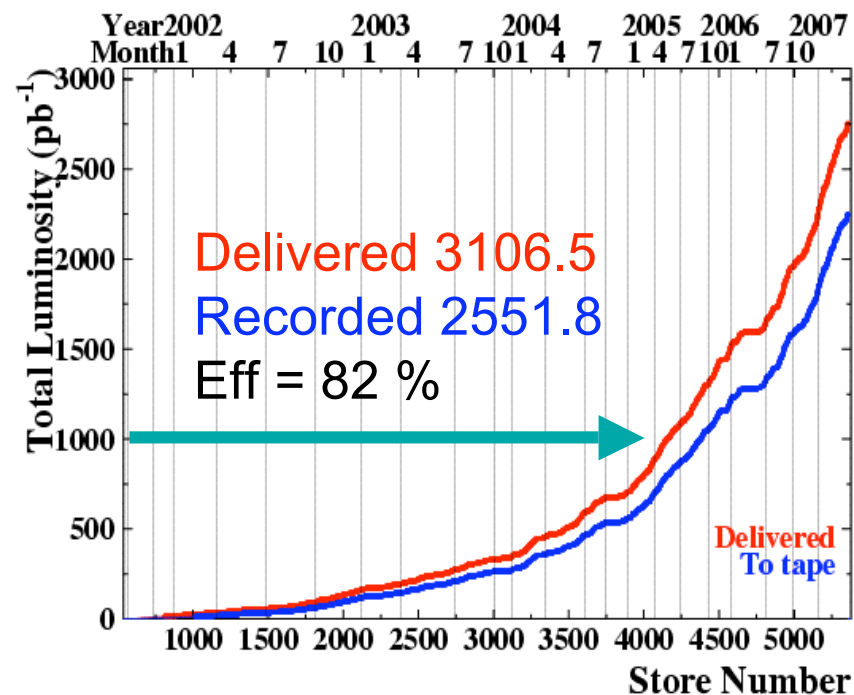
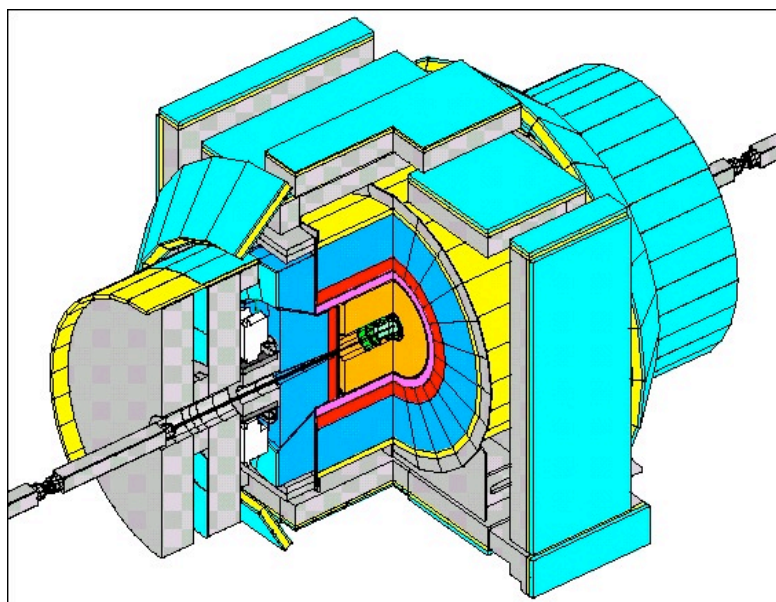

TOP PHYSICS require a good understanding of the entire detector

TOP QUARK PRODUCTION & DECAY



Produce in pairs via strong interaction

At $\sqrt{s}=1.96$ (14) TeV:
 85 (10) $\pm 5\%$ qq
 15 (90) $\pm 5\%$ gg

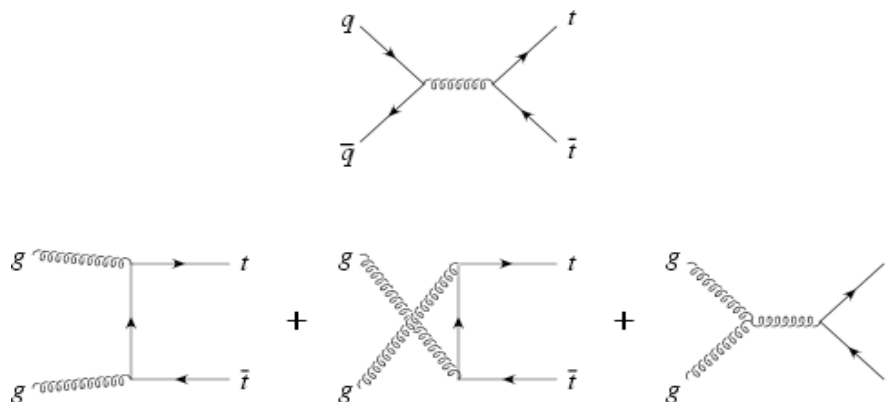

Decay via electroweak interaction $\sim 100\%$ BR($t \rightarrow W^+ b$)

$tt \rightarrow W(\rightarrow lv)bW(\rightarrow lv)b$ (e+ μ : 5%)
 low background, low yield
 \rightarrow DILEPTON SAMPLE

$tt \rightarrow W(\rightarrow lv)bW(\rightarrow qq)b$ (e+ μ : 35%)
 background moderate, medium yield
 \rightarrow LEPTON PLUS JETS SAMPLE

$tt \rightarrow W(\rightarrow qq)bW(\rightarrow qq)b$ all hadronic (45%)
 high background, high yield

Top Pair Decay Channels

$\bar{c}s$	electron+jets	muon+jets	tau+jets	all-hadronic	
$\bar{u}d$					
τ^-	$e\tau$	$\mu\tau$	$\tau\tau$		
μ^-	$e\mu$	$\mu\mu$	$\mu\tau$	muon+jets	
e^-	ee	$e\mu$	$e\tau$	electron+jets	
W decay	e^+	μ^+	τ^+	$u\bar{d}$	$c\bar{s}$

$\sigma(\text{pp-bar} \rightarrow \text{tt-bar})$ MEASUREMENTS

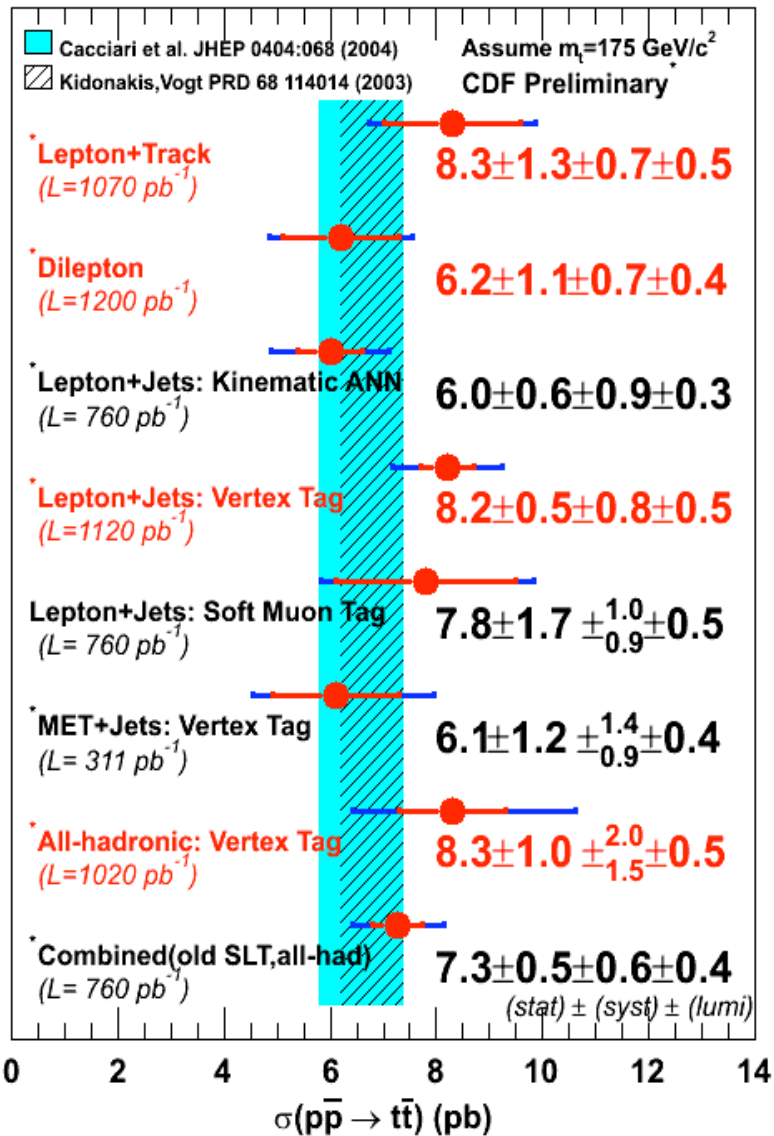

σ_{tt} measured in ALL final states:
 • Independent top quark samples with different non-SM sensitivities.

$$\sigma_{\text{tt}} (\text{CDF}) \cong 7.3 \pm 0.9 \text{ pb}$$

Cacciari et al. JHEP 0404:068 (2004)
 Kidonakis & Vogt PRD 68 114014 (2003)

$$\sigma_{\text{tt}} (\text{NLO-THEO}) \cong 6.7 \pm 0.8 \text{ pb}$$

$$(M_{\text{TOP}} = 175 \text{ GeV}/c^2)$$

12% ACCURACY: THEORY & EXPERIMENT

THE $\sim 1 \text{ fb}^{-1}$ TOP QUARK SAMPLES

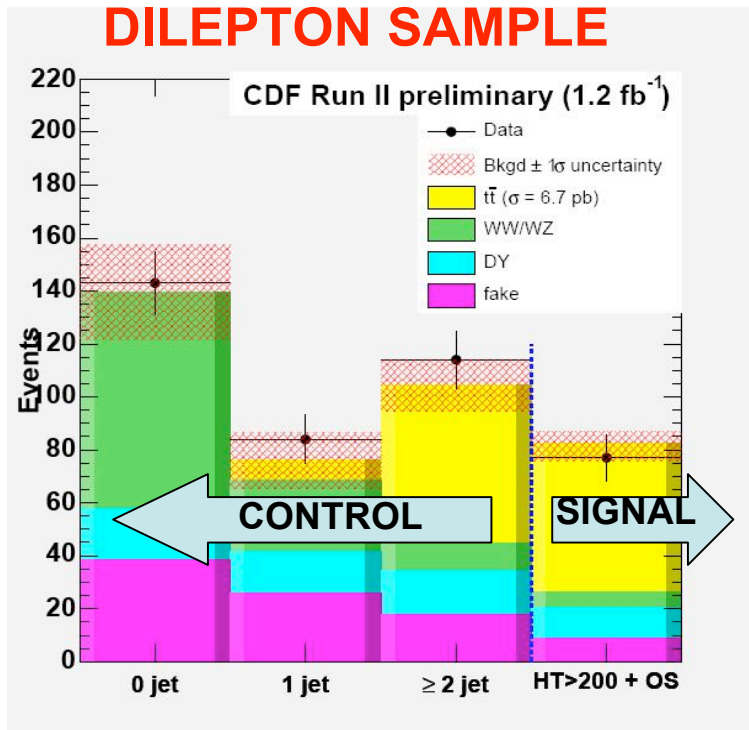

- 2 high P_T leptons (e, μ) $P_T > 20 \text{ GeV}/c$
- 2 high E_T jets.
- High Missing E_T

Total Backgr.	25.6 ± 5.5
$t\bar{t}$ ($\sigma=6.7\text{pb}$)	55.9 ± 4.3
Total SM	81.5 ± 8.9
DATA	77

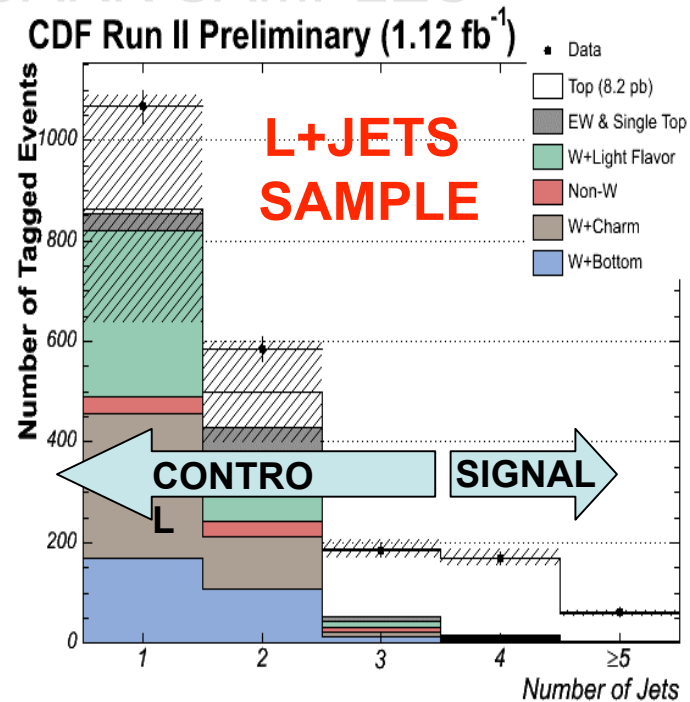

- 1 high P_T lepton (e, μ) $P_T > 20 \text{ GeV}/c$
- ≥ 4 high E_T jets.
- High Missing E_T
- B-tagging with secondary vertex.

	4 jets	≥ 5 jets
Total Backgr.	16.7 ± 5.9	4.7 ± 1.7
$t\bar{t}$ ($\sigma=6.7\text{pb}$)	153.5 ± 15.6	53.6 ± 5.5
Total SM	170 ± 17	58 ± 6
DATA	169	62



$\sigma(gg \rightarrow tt)/\sigma(pp \rightarrow tt): \langle N_{\text{TRK}} \rangle \text{ VS } \langle N_{\text{gluon}} \rangle$

Sensitive to new top production & decay mechanisms simultaneously.

G.L Kane and S. Mrenna Phys. Rev. Lett.77: 3502-3505 (1996)

Top quark from gluino decays and top quark decays to stops

PRINCIPLE: $gg \rightarrow tt$ tends to have more underlying event activity w.r.t $qq \rightarrow tt$

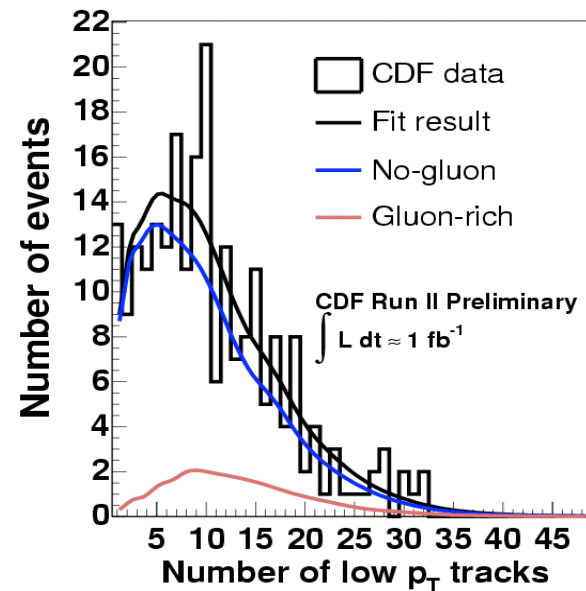
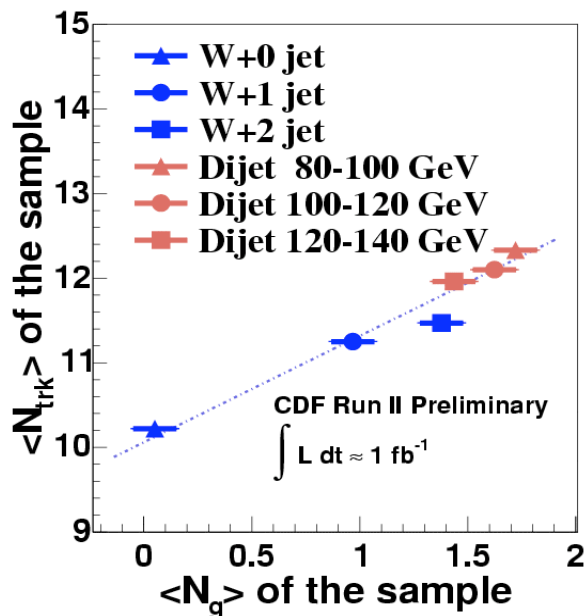

Calibrate $\langle N_{\text{TRK}} \rangle$ (low P_T tracks) vs. $\langle N_g \rangle$ correlation with W+jets and dijet data.

Fit W+jets (b-tagged) data to $\langle N_{\text{TRK}} \rangle$ templates: gluon-rich (DIJET 80-100 GeV)

no-gluon (W+0 jets)

$$\sigma(gg \rightarrow t\bar{t}) / \sigma(p\bar{p} \rightarrow t\bar{t}) = 0.07 \pm 0.14(\text{stat}) \pm 0.07(\text{syst})$$

$\sigma(gg \rightarrow t\bar{t})/\sigma(pp \rightarrow t\bar{t})$:neural network

- **PRINCIPLE:** gg ($q\bar{q}$ -bar) $t\bar{t}$ -bar events tend to be produced with unlike (like) spin.
- Use NN with 8 input variables:
 - 2 in the $t\bar{t}$ -bar reference frame: β and angle top quark-incoming parton.
 - kinematic information from the production.
 - 6 angles between decay products in the “off-diagonal” bases
 - spin correlation information from the decay.
- Fit data to templates built from the NN output shapes.

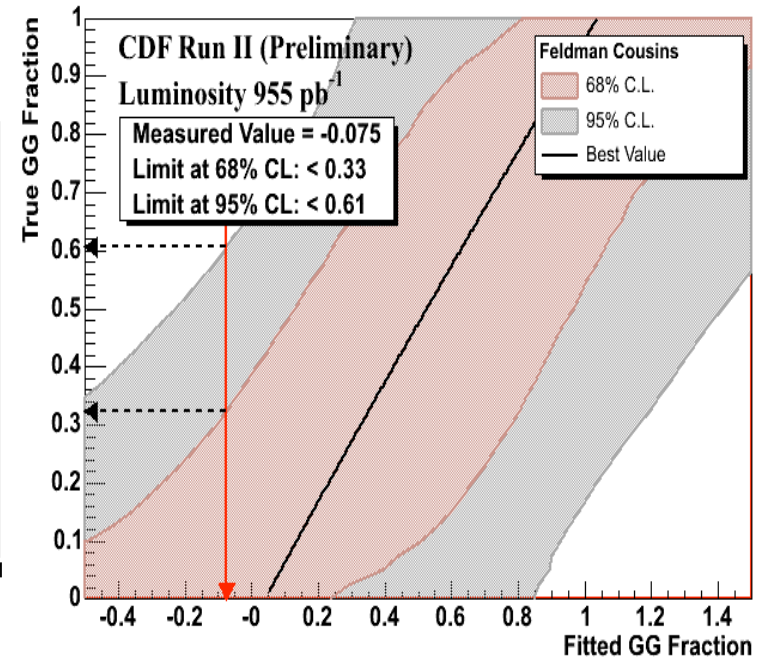
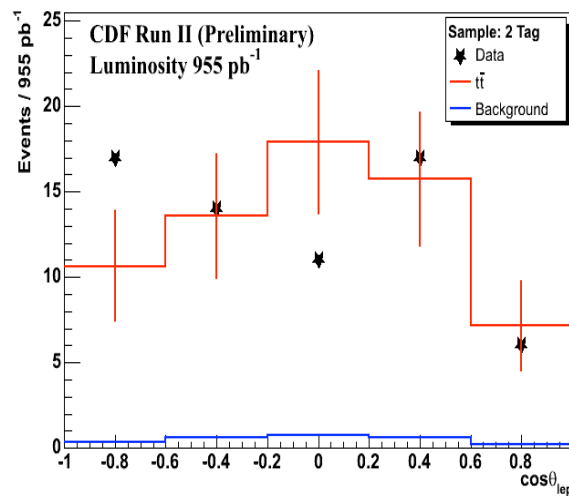
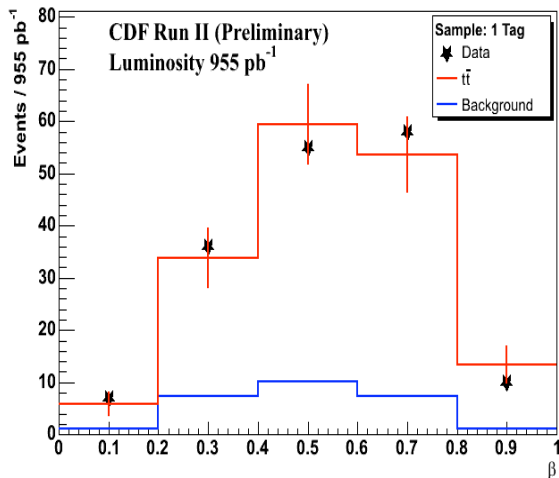

$$\sigma(gg \rightarrow t\bar{t}) / \sigma(p\bar{p} \rightarrow t\bar{t}) < 0.61 @ 95\% CL$$

Search for resonant top pair production



- Sensitive to new resonant t-tbar production mechanisms:
 - Extended Gauge Theories
 - (A. Leike, Phys. Rep. 317, 143, 1999, hep-ph/9805494)
 - KK states of the gluon , Z
 - (J. Rosner, CERN-TH/96-169, 1996, B. Lillie, hep-ph/0701166)
 - Topcolor
 - (C. Hill, S. Park, PRD49, 4454, 1994)

- Search for narrow width Z' (1.2% of the mass) with same coupling as Z0
 - no resonant interference with the s channel gluon production.
- Reconstruct $M_{t\bar{t}}$ with kinematic fitter.
- Binned likelihood fit of data to 3 templates:
 - SM $t\bar{t}$, $Z' \rightarrow t\bar{t}$, non $t\bar{t}$
 - Range of Z' masses (450-900 GeV/c^2)

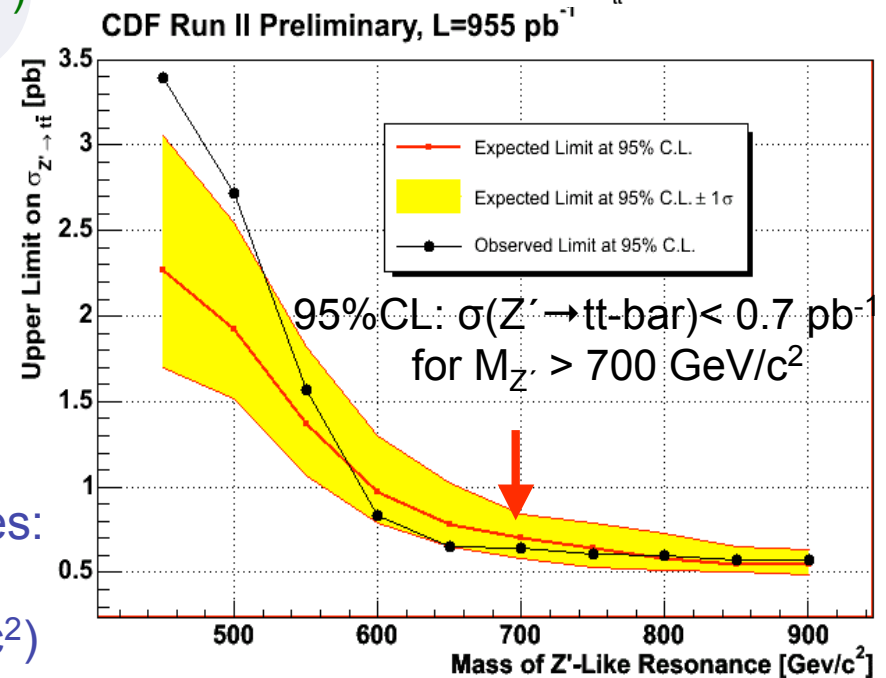
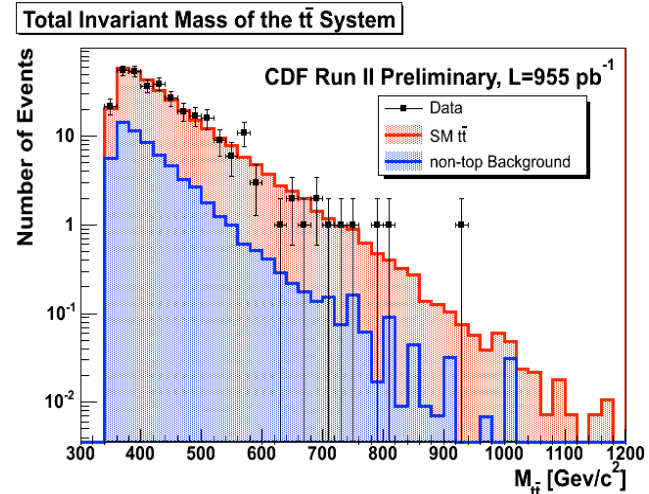

Search for a Heavy Top $t' \rightarrow Wb$

- Hypothesis: t' is pair-produced strongly, heavier than SM top quark, decay to Wb .
 - 2HD models and N=2 SUSY models can accommodate a heavier 4th fermion generation with $m_{Z/2} < m_f < m_{\text{Higgs}}$ (hep-ph/0102144, hep-ph/0111028)
 - Other models: “Beautiful mirrows” (hep-ph/0109097)

- Data fitted to templates (t' , top, background) with 2D binned likelihood (H_T and M_{RECO})

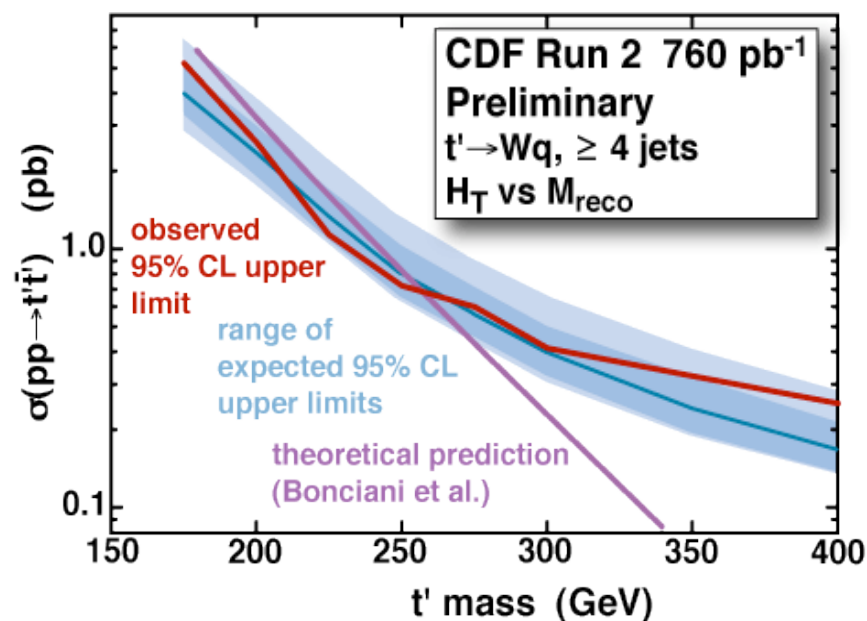
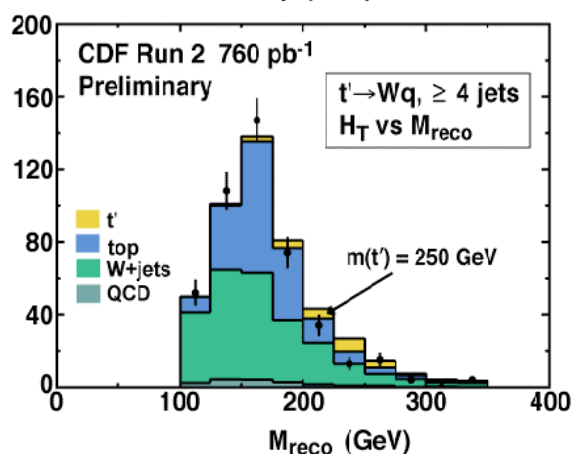
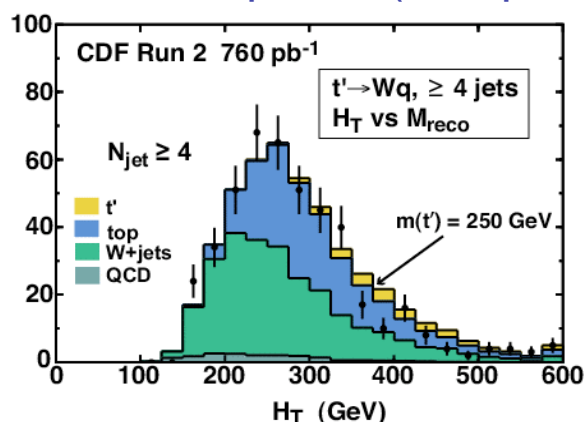

$m_{t'} > 256 \text{ GeV} / c^2 @ 95\%CL$

Event Displays: high H_T high M_{REC} candidates

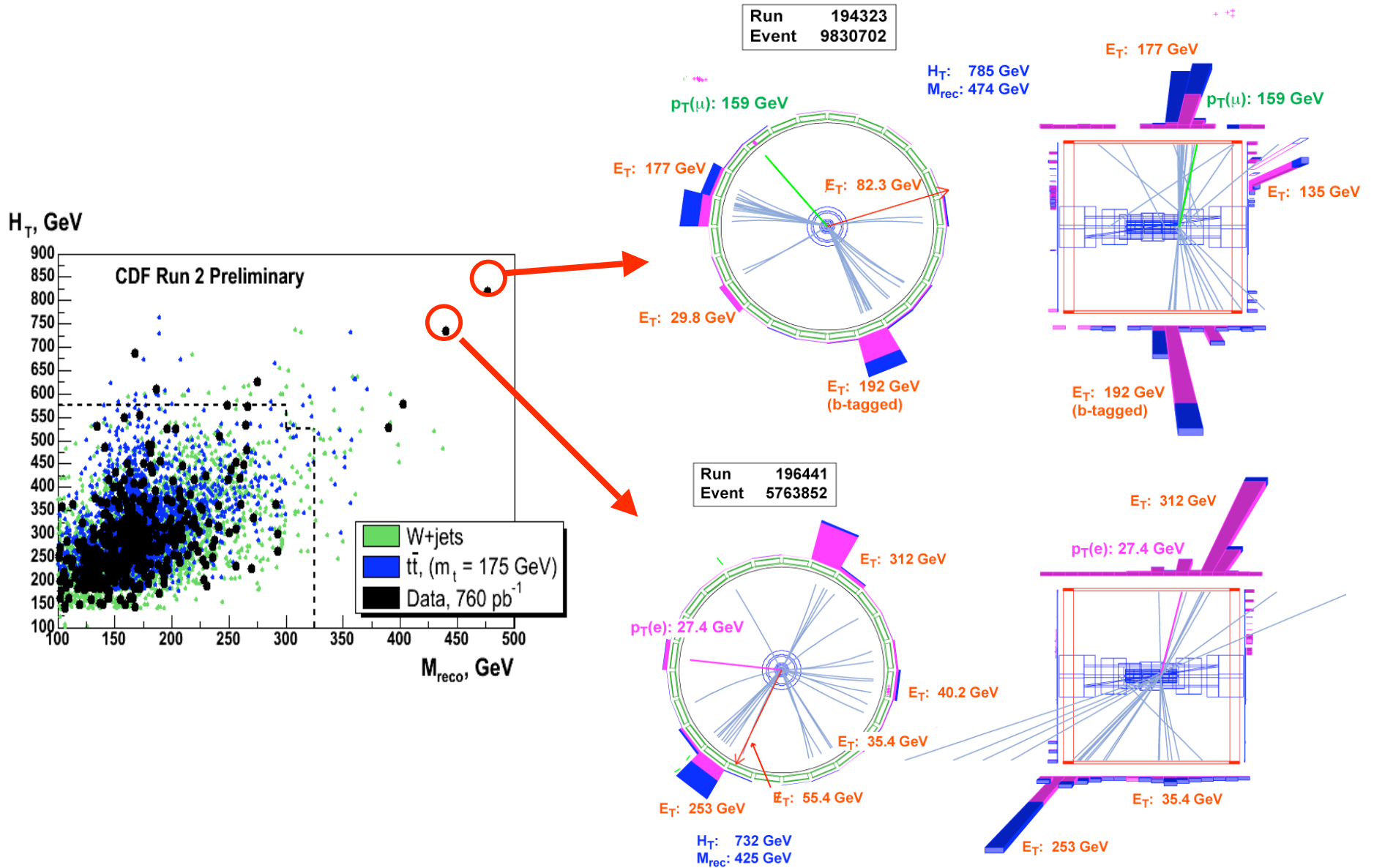

Top quark charge: +2/3 or -4/3 ?

- Hypothesis: Top quark charge = $-4e/3$
 - New exotic quark part of a fourth generation. D.Chang et al. PRD 59, 09153(99)

- A challenging experimental method:

- Jet Charge algorithm:

$$Q_{bjet} = \frac{\sum_i q_i^{track} (\vec{p}_i^{track} \cdot \hat{a}_{jet})^{0.5}}{\sum_i (\vec{p}_i^{track} \cdot \hat{a}_{jet})^{0.5}}$$

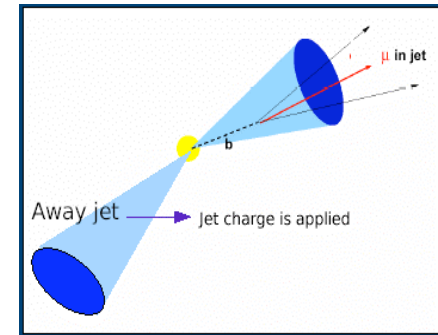

- Calibration with dijet data bb -bar enriched
- “Purity”:= probability of correctly pairing Wb and getting the correct flavor of b -jet
- Counting experiment:
 - 62 Standard Model-like (SM)
 - 48 Exotic Model-like (XM)
- Likelihood versus f_{\pm} = Fraction of pairs with charge $2e/3$ in data.
- Result:

Consistent with charge $2e/3$ hypothesis
Exclude charge $-4e/3$ hypothesis at 81% confidence

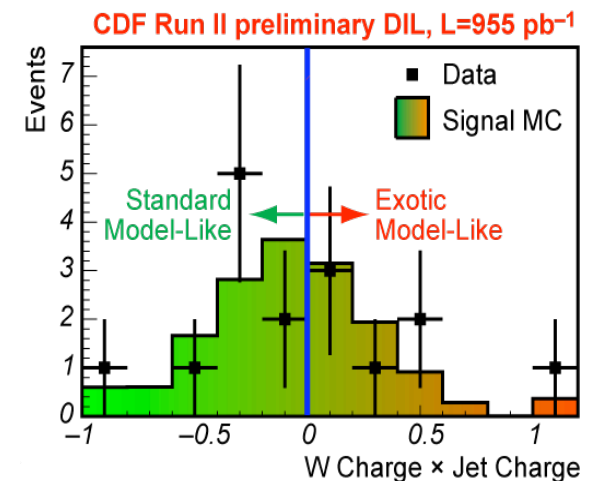

Search for the FCNC decay $t \rightarrow Zq$



- SM: Top quark FCNC highly suppressed (GIM mechanism and CKM suppression)
- Beyond SM scenarios enhance top FCN decays providing observable BR's
- [Acta Phys. Polon. B35 \(2004\) 2695-2710, hep-ph/0409342](#)

Model	SM	Q=2/3 quark singlets	2HDM	MSSM	RPV-SUSY
BR($t \rightarrow qZ$)	$\sim 10^{-14}$	$\sim 10^{-4}$	$\sim 10^{-7}$	$\sim 10^{-6}$	$\sim 10^{-5}$

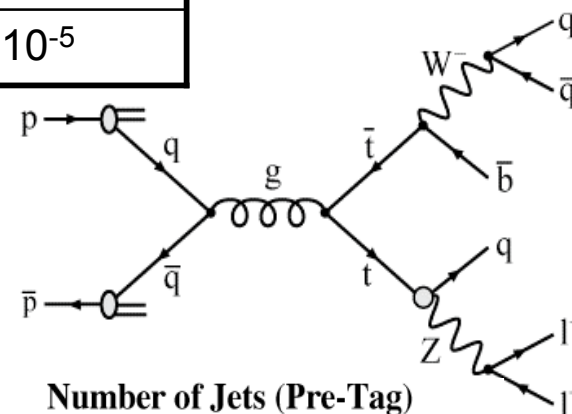

- **Blind search in $tt \rightarrow Zq Wb$**
 - $Z \rightarrow e^+e^-, \mu^+\mu^-$ (clean signature)
 - 4 jets (larger BR of hadronic $W \rightarrow qq'$)
 - Two separate signal regions: zero b-tags – one or more b-tag
- **Backgrounds: from data-driven and MC methods**
 - Dominant background: Z+Jets production
 - Smaller backgrounds: tt and diboson (WZ, ZZ)

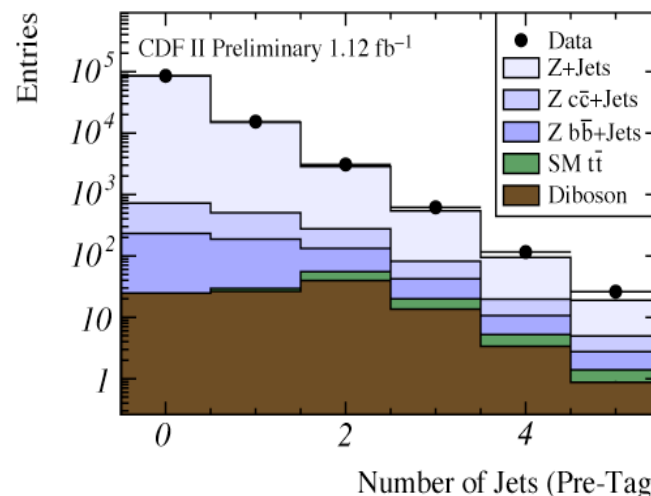

Search for the FCNC decay $t \rightarrow Zq$ (Cont')



- Optimize event selection for best expected limit

- Strongest discriminator: Mass χ^2 : reconstructed W, SM Top and NON-SM FCNC Top masses

$$\chi^2 = \left(\frac{m_{W,rec} - m_{W,PDG}}{\sigma_{W,rec}} \right)^2 + \left(\frac{m_{t \rightarrow Wb,rec} - m_{t,PDG}}{\sigma_{t \rightarrow Wb}} \right)^2 + \left(\frac{m_{t \rightarrow Zq,rec} - m_{t,PDG}}{\sigma_{t \rightarrow Zq}} \right)^2$$

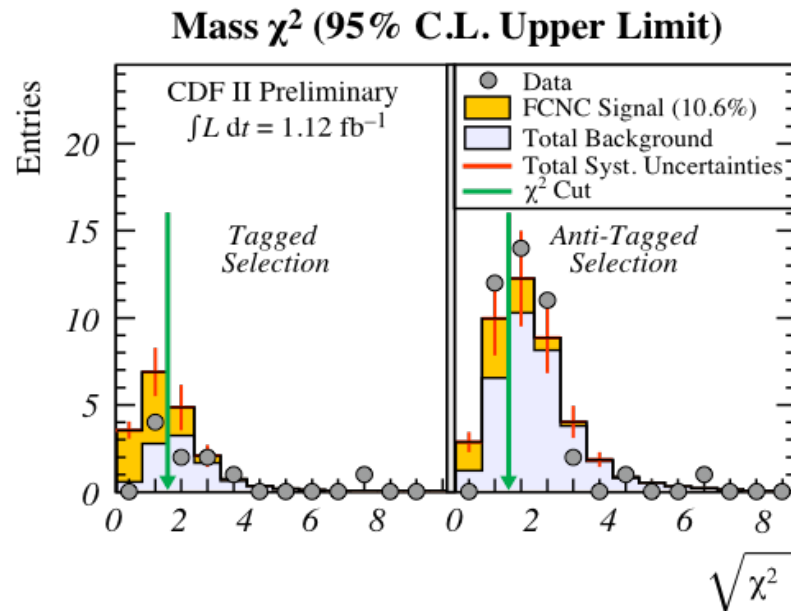

- Unblinding after optimization: observed numbers events consistent with background

Selection	Observed	Expected
Base Selection	141	130 ± 28
Base Selection (Tagged)	17	20 ± 6
Anti-Tagged Selection	12	7.7 ± 1.8
Tagged Selection	4	3.2 ± 1.1

$B(t \rightarrow Zq) < 10.6\% @ 95\% \text{ C.L.}$

- New world's best limit: improves previous limit by 25% (13.7% from non-observation of $e^+e^- \rightarrow tq$ at LEP,L3)

W Helicity in Top Quark Decays

SM: Top quark decays via weak interaction to spin-1 W^+ boson and spin-1/2 b quark
 → V-A coupling like all other fermions:

$$\frac{-ig}{2\sqrt{2}} \bar{t} \gamma^\mu (1 - \gamma^5) V_{tb} b W_\mu$$

V+A is Suppressed in the SM

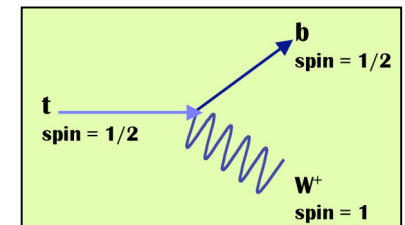
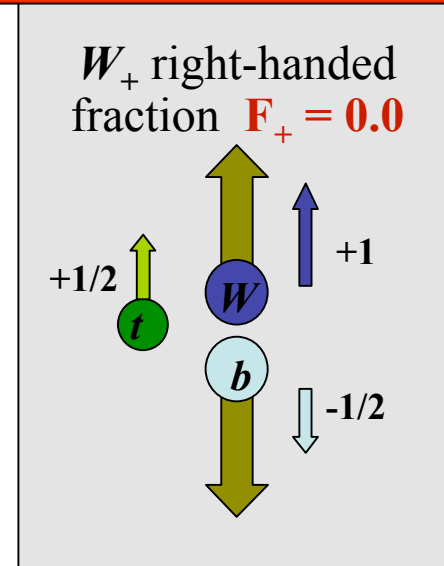
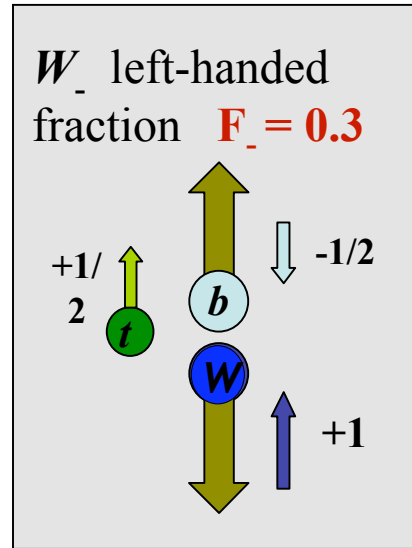
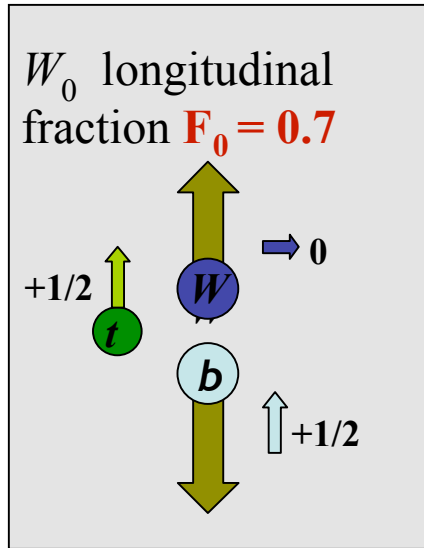

In general, t-W-b coupling can have form-factors of type: V-A (standard model), V+A and Magnetic-moment [G.L. Kane, G.A. Ladinsky, C.P. Yuan Phys. Rev. D 45, 124 \(1992\)](#)

The presence of V+A could signal new physics: Left-right symmetric models? Mirror fermions?
[Beg, Mohapatra et al. Phys.Rev.Lett.38:1252, 1977](#)
[Triantaphyllou: J.Phys.G26:99,2000](#)
[Tait, Yuan, He et al.:Phys.Rev.D62:011702,2000, Phys.Rev.D65:053002,2002](#)

W-helicity: $\cos\theta^*$ method

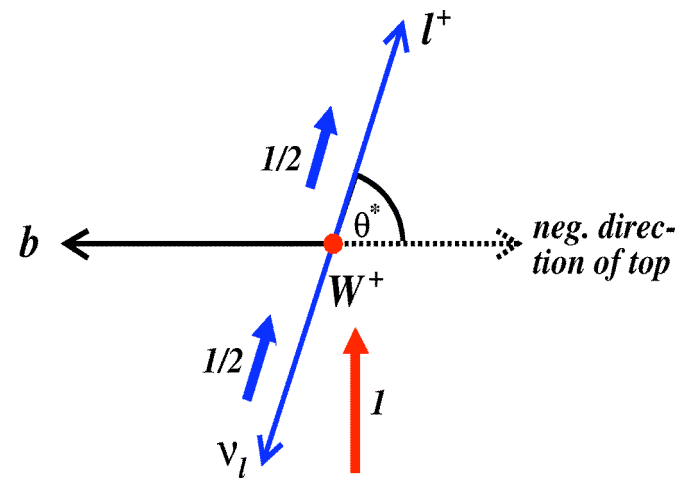
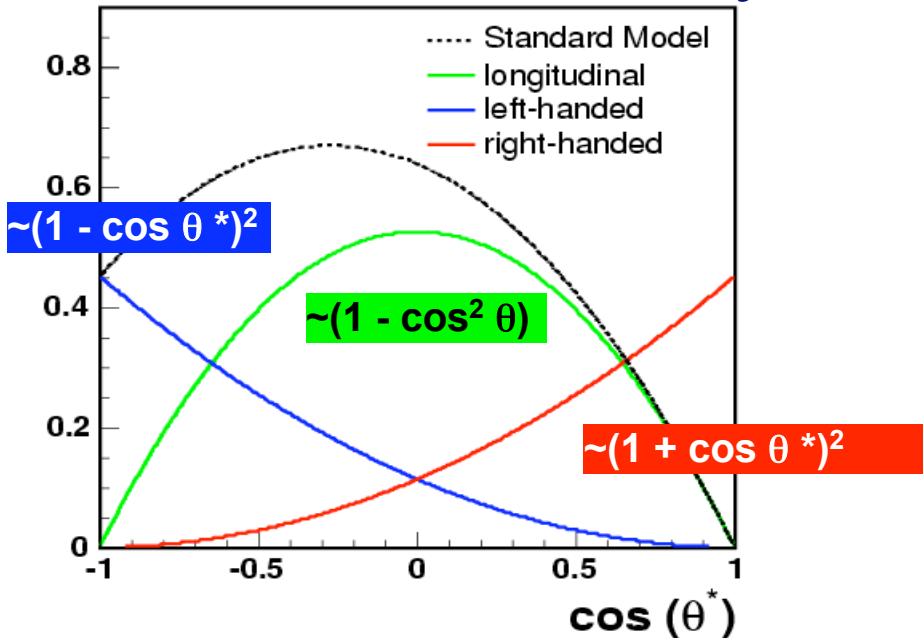

$$\frac{1}{\Gamma} \frac{d\Gamma}{d\cos\theta^*} = \frac{3}{4}(1 - \cos^2\theta^*)F^0 + \frac{3}{8}(1 - \cos\theta^*)^2 F^- + \frac{3}{8}(1 + \cos\theta^*)^2 F^+$$

- L+JETS sample with $N_{\text{JETS}} \geq 4$ and ≥ 1 btag.
- $t\bar{t}$ kinematics fully reconstructed.
- Extract $\cos\theta^*$ by boosting lepton and top into W rest frame.
- Two methods to extract F_0 and F_+ (next two slides)
- 3 set of results:
 - 1-Parameter-fit: F_0 fixed to 0.7 \rightarrow Test possible V+A contribution in weak interactions
 - 1-Parameter-fit: F_+ fixed to 0. \rightarrow Test possible anomalous couplings (non zero-magnetic moment couplings)
 - 2-Parameter-fit \rightarrow MODEL INDEPENDENT

W-helicity: $\cos\theta^*$ method (I) 1.73 fb^{-1}



FIRST METHOD TO EXTRACT F_0 AND F_+

- Binned likelihood fitter:
 - Fits data to signal and background templates.
 - Signal Templates: from theoretical principles corrected for detector efficiency and resolution

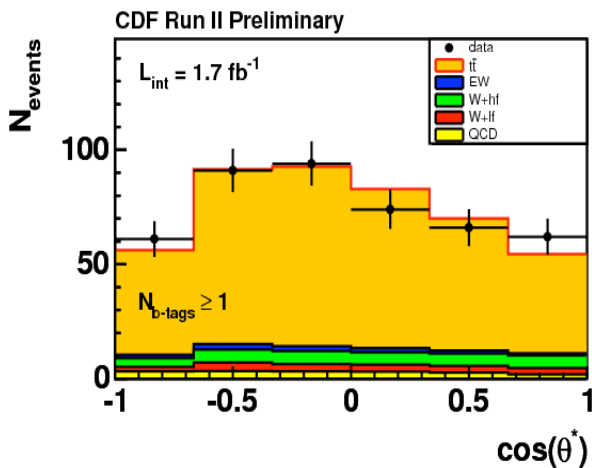

Unfolding of measured distribution:
Correct for efficiency and resolution effects.

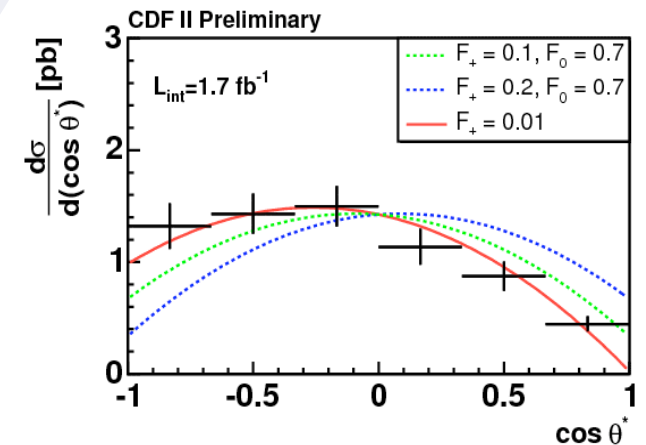
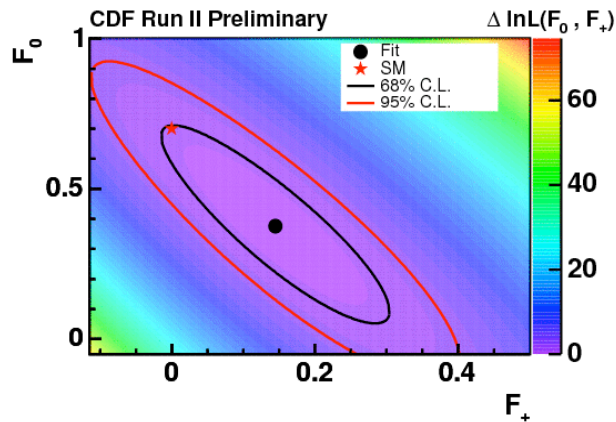
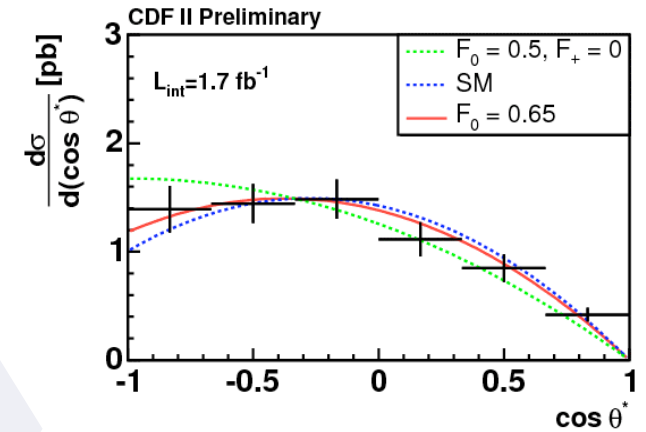

$f_0 = 0.38 \pm 0.22_{\text{stat}} \pm 0.07_{\text{syst}}$ and $f_+ = 0.15 \pm 0.10_{\text{stat}} \pm 0.04_{\text{syst}}$
 $f_0 = 0.65 \pm 0.10_{\text{stat}} \pm 0.06_{\text{syst}}$ with $f_+ = 0$
 $f_+ = -0.01 \pm 0.05_{\text{stat}} \pm 0.03_{\text{syst}}$ with $f_0 = 0.7$ $f_+ < 0.12$ @95% CL

W-helicity: $\cos\theta^*$ method (II) 1 fb^{-1}



SECOND METHOD TO EXTRACT F_0 AND F_+

- Unbinned likelihood fitter.
- Fits data to signal and MC shapes:
 - 3rd order polynomial times exponent parameterizations from templates.

CDF II Preliminary

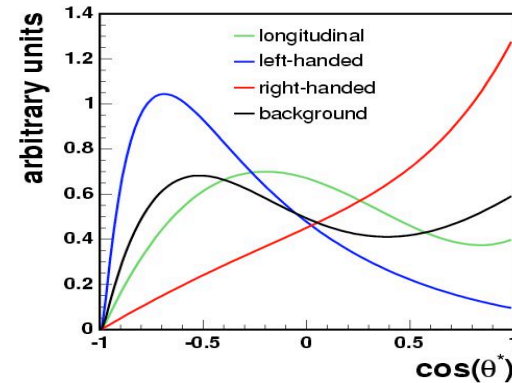

CDF II Preliminary

Entries 220

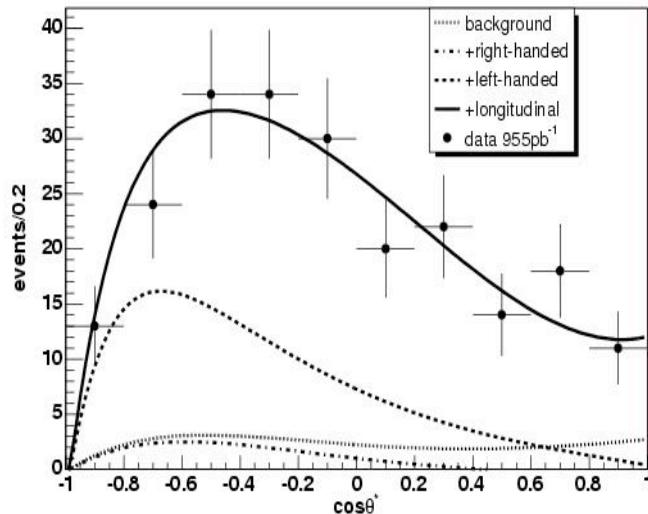

CDF II preliminary, 955 pb^{-1}

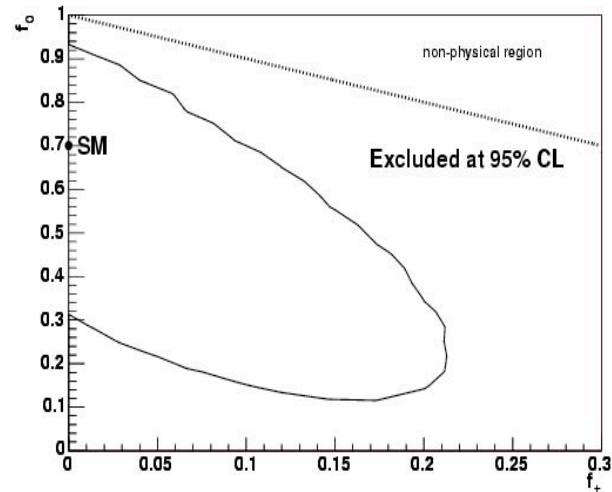

$f_0 = 0.74 \pm 0.25_{\text{stat}} \pm 0.06_{\text{syst}}$ and $f_+ = -0.06 \pm 0.10_{\text{stat}} \pm 0.03_{\text{syst}}$
 $f_0 = 0.61 \pm 0.12_{\text{stat}} \pm 0.06_{\text{syst}}$ with $f_+ = 0$
 $f_+ = -0.06 \pm 0.06_{\text{stat}} \pm 0.03_{\text{syst}}$ with $f_0 = 0.7$ $f_+ < 0.11$ @95% CL

CONCLUSIONS AND PROSPECTS



- The CDF top quark samples with $L = 1.1 - 1.2 \text{ fb}^{-1}$ have been reestablished:
 - Top pair production cross section has been measured and found in good agreement with QCD-NLO predictions.
- A lot of challenging and creative “ALTERNATIVE” searches have been performed on the CDF top quark samples in order to find NEW PHYSICS.
 - New production mechanisms: resonances, t' , etc
 - New decay mechanisms: FCNC $t \rightarrow Zq$
 - Search for deviations in SM values of measured top properties: charge, W helicity.
 - For the time being are very statistical limited, but the methodology is in place.
 - 2fb^{-1} analyses coming by the end of summer.

NO EVIDENCE OF NEW PHYSICS IN THE 1 fb^{-1} CDF TOP QUARK SAMPLES

- All the ongoing CDF analysis techniques described can be applied to search for new physics in the TEVATRON PHASE OF THE LHC (early LHC data $0.1-1 \text{ fb}^{-1}$)
 - Background methods for total rates and shapes.
 - Determination of systematic uncertainties.
 - Statistical machinery to extract limits.

Backup slides.



Charged Higgs from Top quark decays

Branching ratio for $t \rightarrow H^+ b$ significant ($>10\%$) for small and large $\tan\beta$

H^+ decays differently than W^+ :

- $H^+ \rightarrow \tau^+ \nu_\tau$ enhanced if high $\tan\beta$:
 - Excess of taus
- $H^+ \rightarrow t^* \bar{b} \rightarrow W^+ b \bar{b}$ for high $m(H^+)$ if low $\tan\beta$:
 - Mimics SM signature but observe more b-tags
- $H^+ \rightarrow c \bar{s}$: defect all channels.

Compare number of observed events in 4 ttbar final states:

dilepton, $e\tau_h + \mu\tau_h$,

lepton+jets with single b-tag, and lepton+jets with double b-tags

(Phys. Rev. Lett 96,042003)

Limits on BR($t \rightarrow H^+ b$)

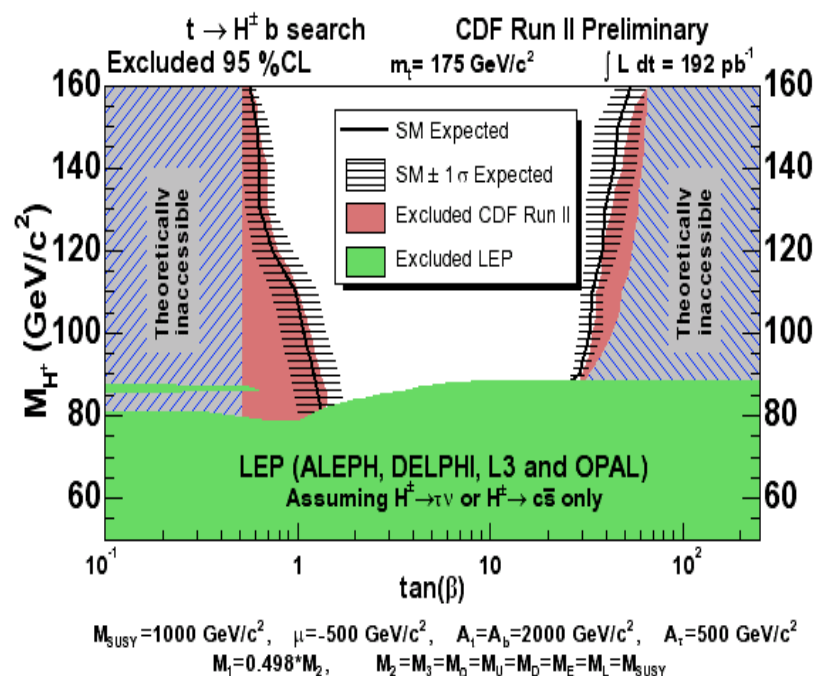
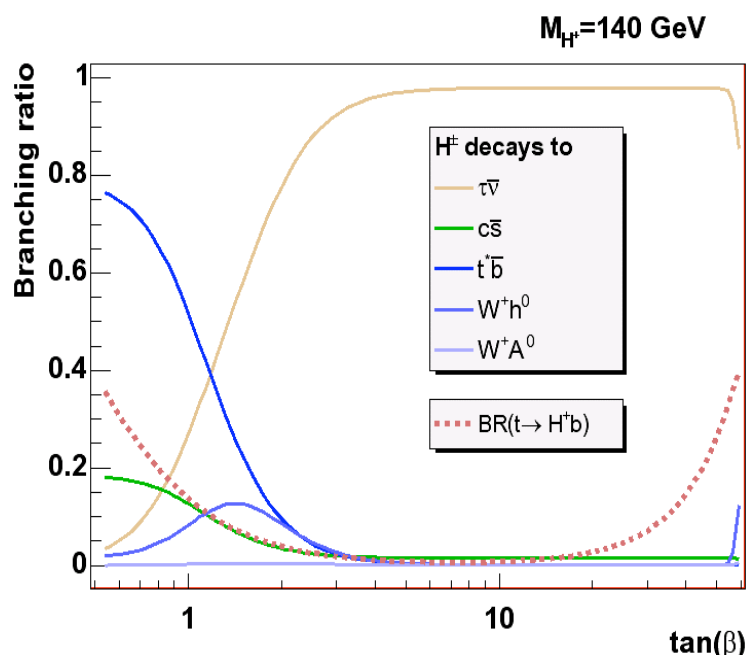

W'-like resonances in the tb-bar decay channel.



- Beyond SM models predict massive W-like bosons describing resonant tb production:
 - Extra dimensions, PL B538, 406 (2002)
 - Top Color PL B385,304 (1996)
- Single Top analysis methods applied to search for a narrow peak in M_{WJJ}
- Set limits on W' production and it's coupling to fermion.

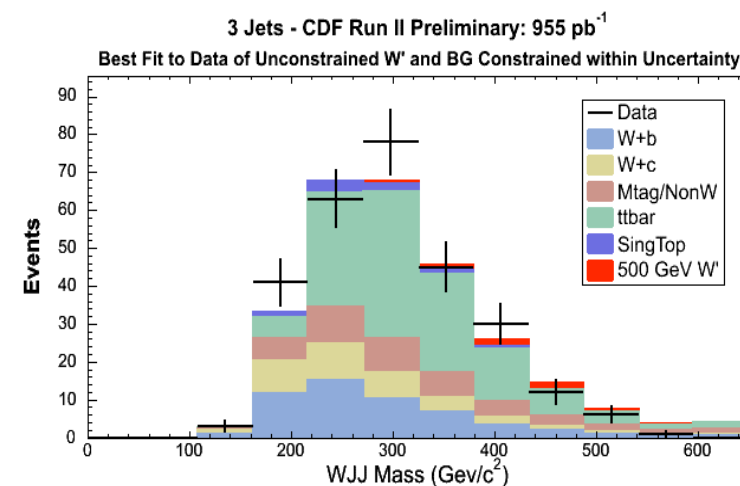
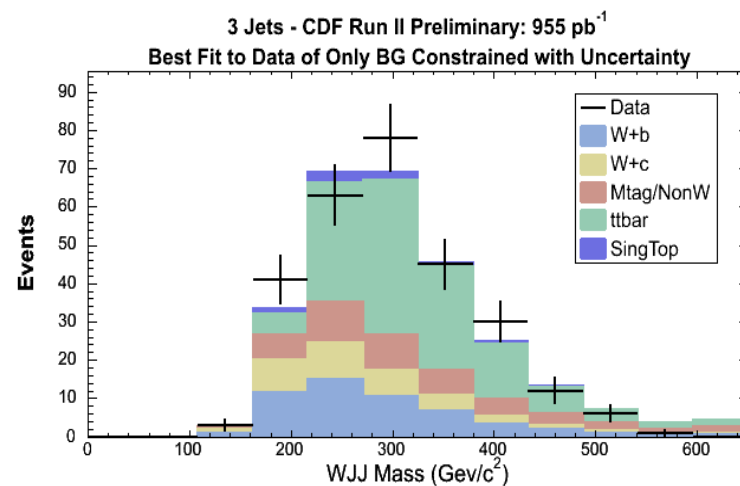
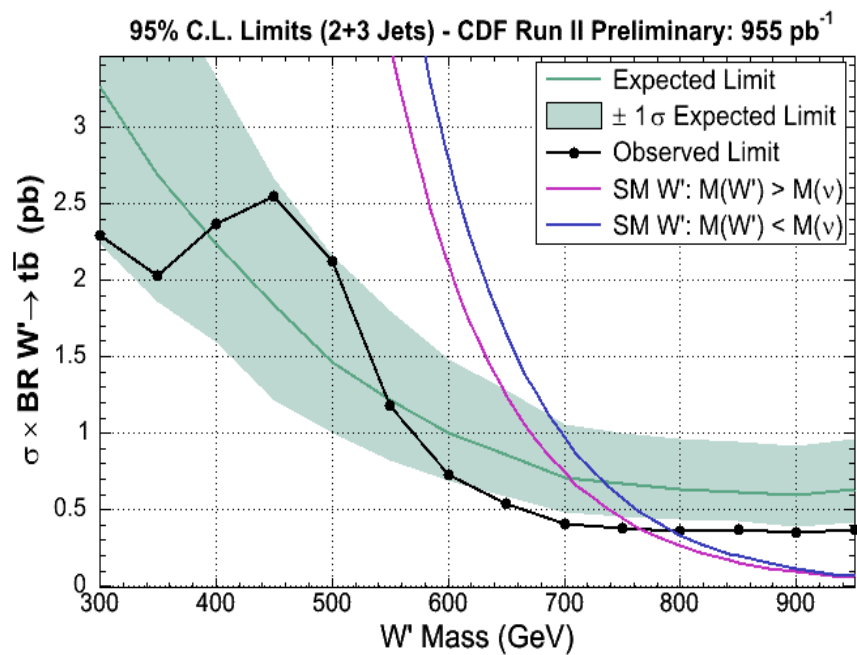
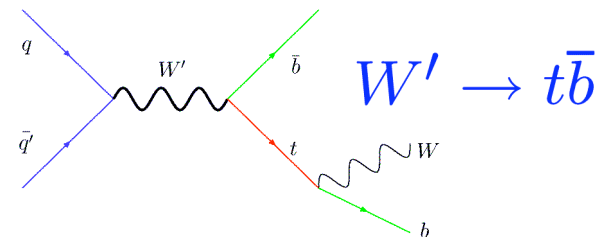

A COMMON TOOL: THE “TOP MASS” KINEMATIC FITTER

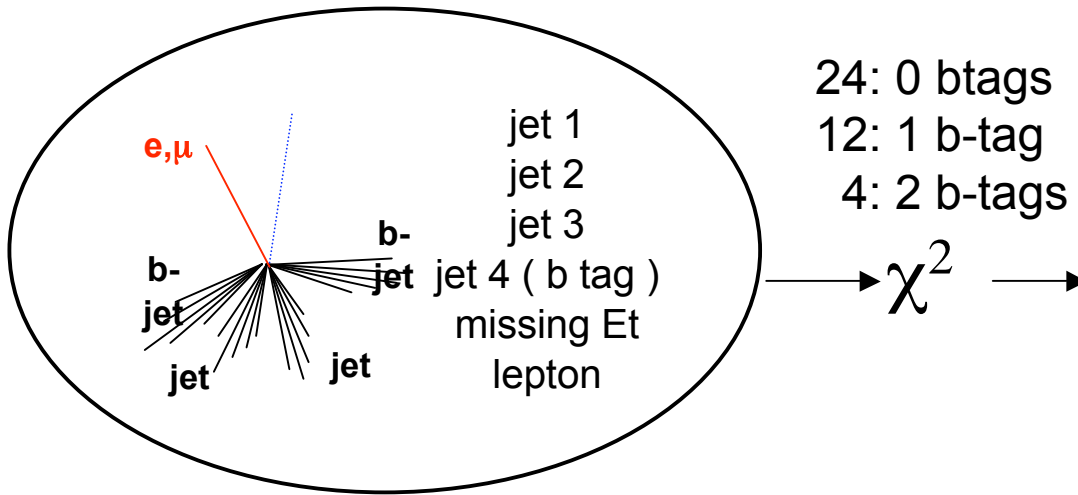

24: 0 btags
 12: 1 b-tag
 4: 2 b-tags

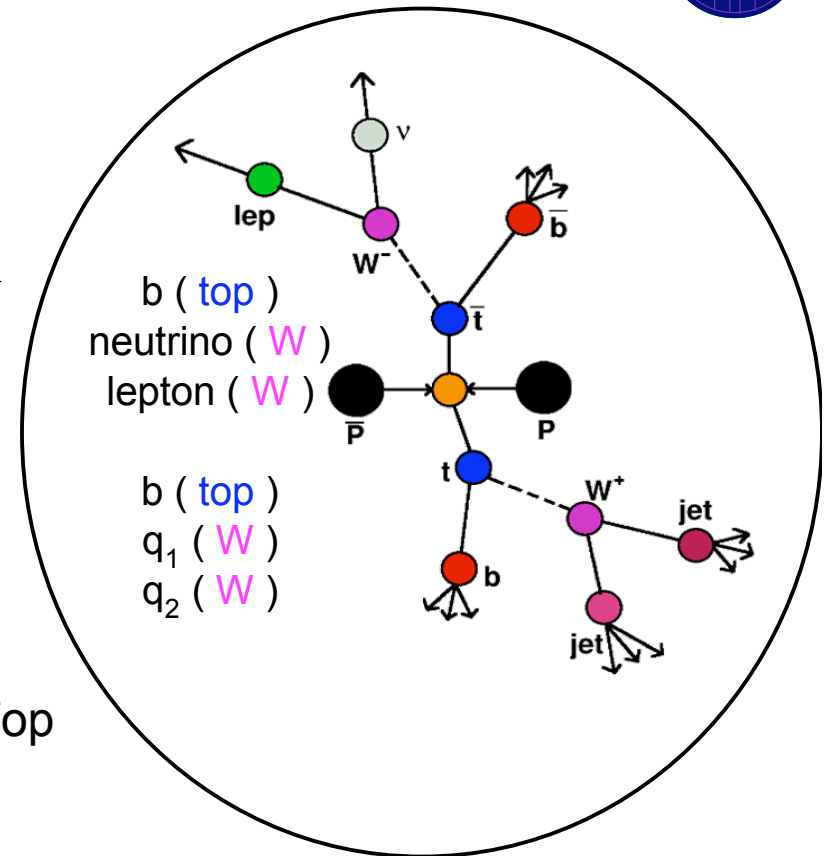

- Reconstruction of kinematics:
 - Constrain jet-jet mass to W mass.
 - Constrain lepton-neutrino mass to W mass
 - Constrain b-lepton-neutrino and b-jet-jet to Top masses.
 - Top mass equal to anti-top mass
 - Lowest χ^2 gives correct combination in 70% of the cases

$$\chi^2 = \sum_{i=l,4 \text{ jets}} \frac{(p_T^{i,fit} - p_T^{i,meas})^2}{\sigma_i^2} + \sum_{j=x,y} \frac{(p_j^{UE,fit} - p_j^{UE,meas})^2}{\sigma_{UE}^2} + \frac{(M_{lv} - M_W)^2}{\Gamma_W^2} + \frac{(M_{jj} - M_W)^2}{\Gamma_W^2} + \frac{(M_{blv} - m_t^{reco})^2}{\Gamma_t^2} + \frac{(M_{bjj} - m_t^{reco})^2}{\Gamma_t^2}$$