

A vertical IceCube detector string is shown on the left side of the slide. It consists of a central cable with several spherical detector modules attached. Each module has a white outer shell and a glowing green inner core. The string is suspended by thin cables from a larger structure above.

IceCube

francis halzen

- cosmogenic neutrinos
- the energetics of cosmic ray sources
- neutrinos associated with cosmic rays
- a cubic kilometer detector
- evidence for extraterrestrial neutrinos
- conclusions

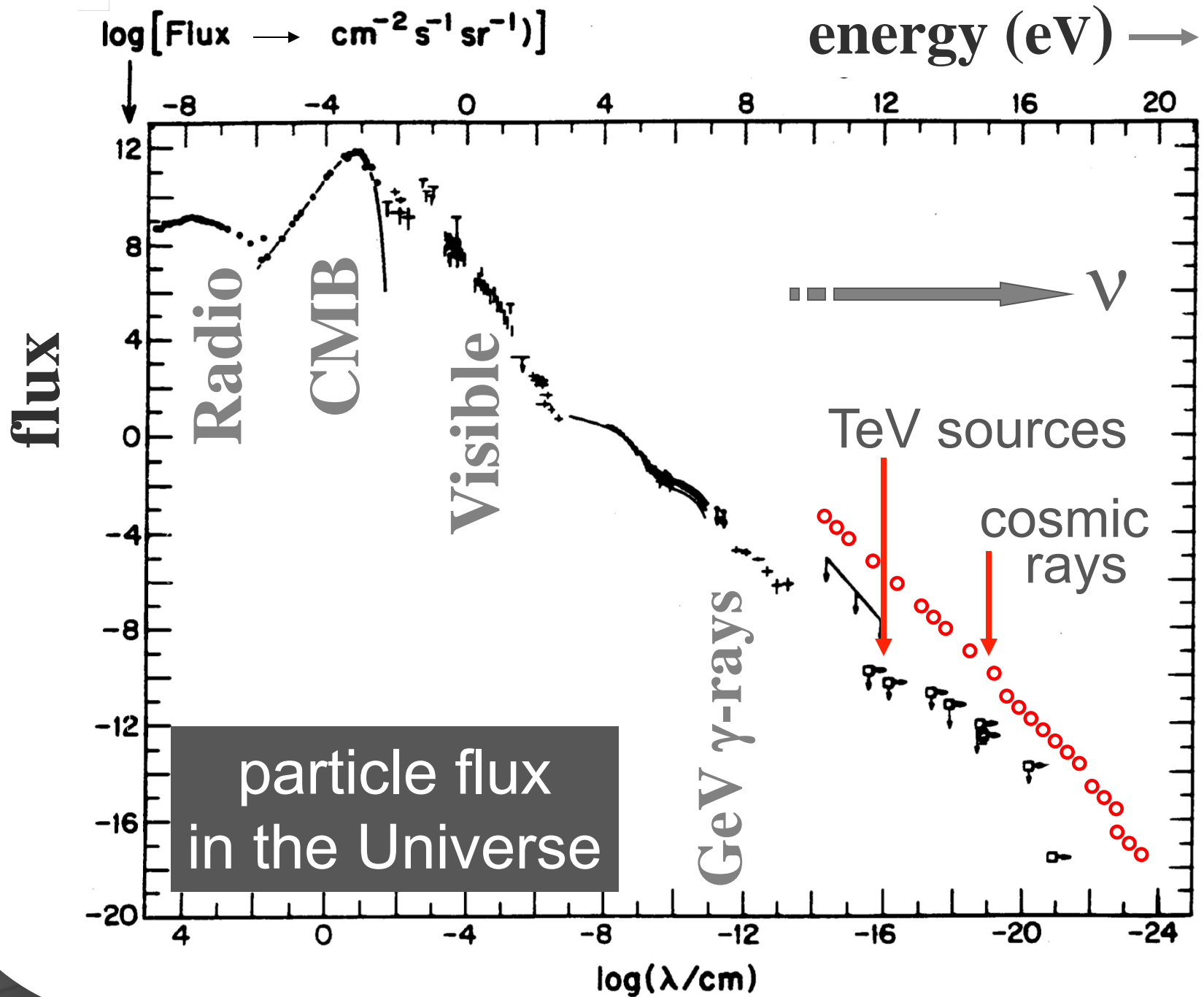

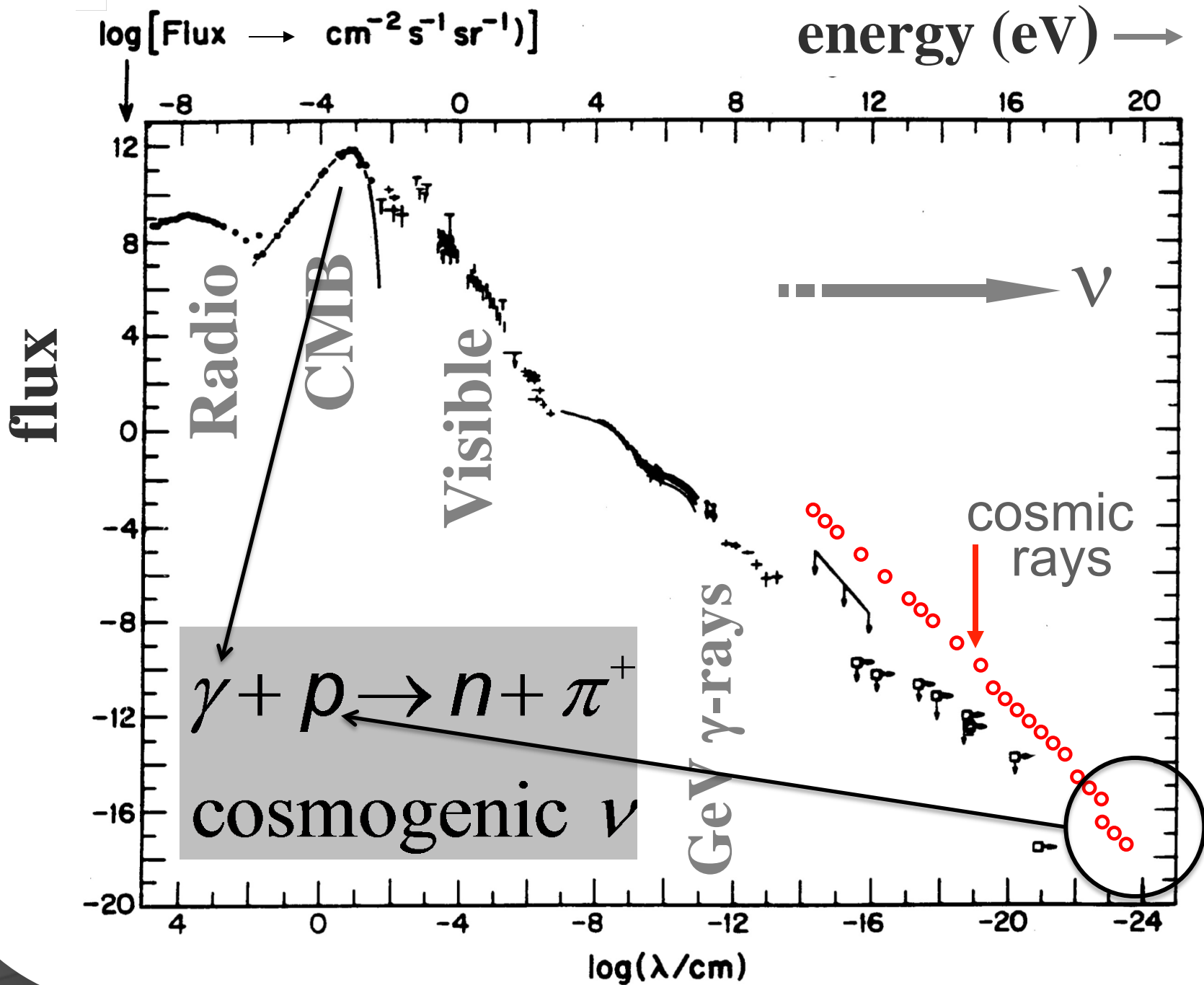

cosmic rays interact with the
microwave background

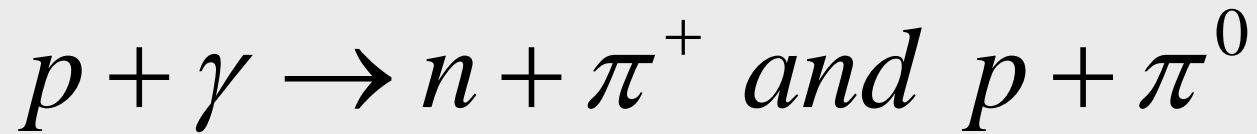

cosmic rays disappear, neutrinos with
EeV (10^{18} eV) energy appear

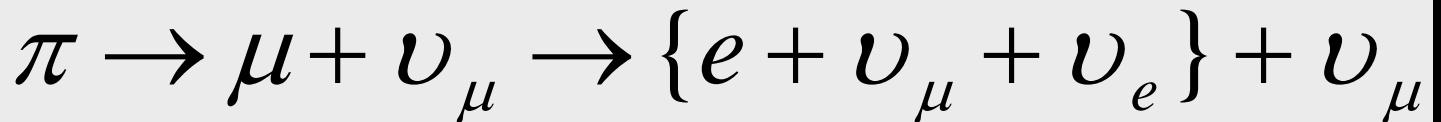

1 event per cubic kilometer per year
...but it points at its source!

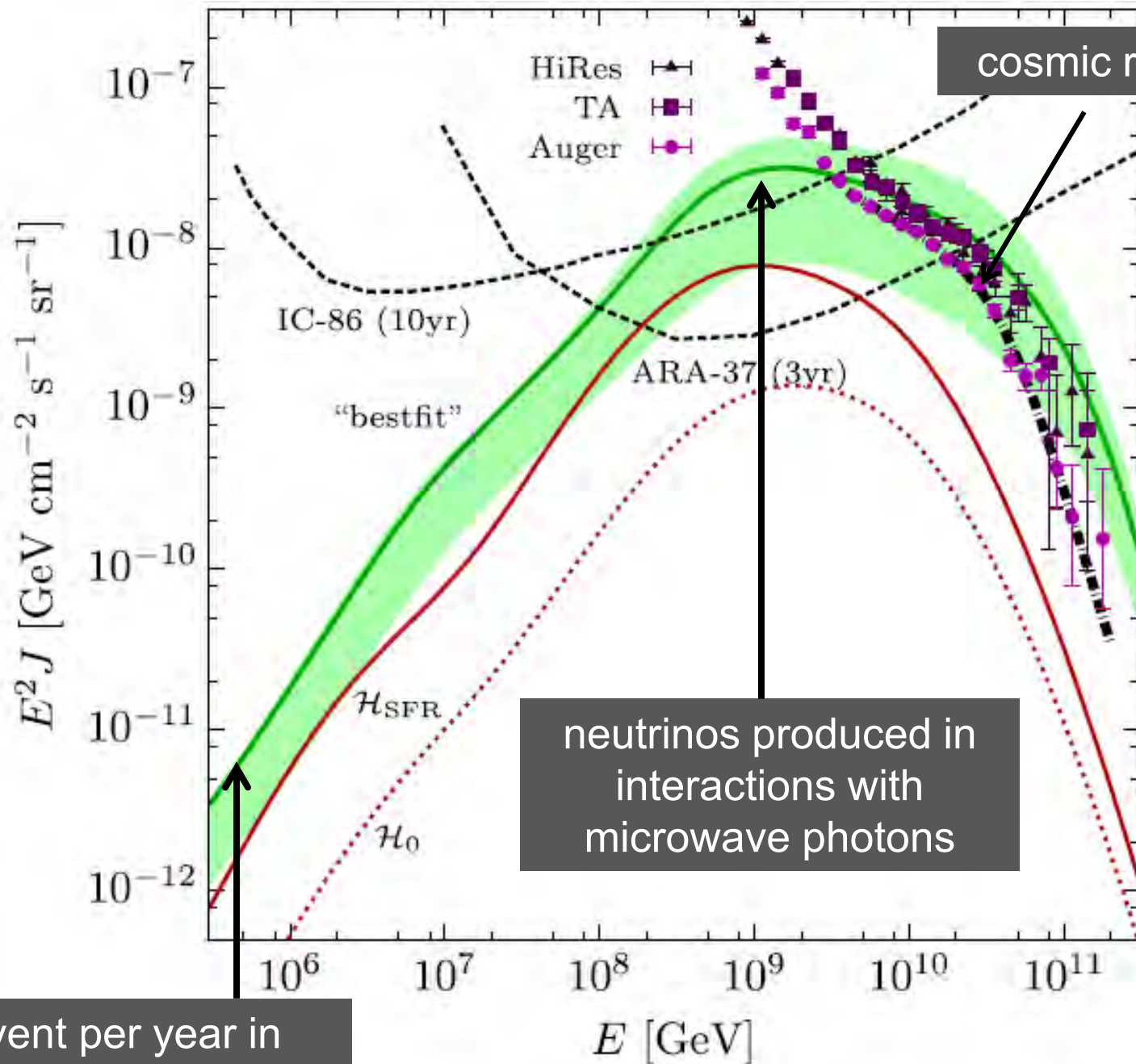

~ 1 event per year in IceCube, PAO and ARA

A vertical IceCube detector string is shown on the left side of the slide. It consists of a central cable with several spherical detector modules attached. Each module has a white band around its middle and is illuminated with a blue and green glow. The string is suspended from the top and extends downwards.

IceCube

francis halzen

- cosmogenic neutrinos
- the energetics of cosmic ray sources
- neutrinos associated with cosmic rays
- a cubic kilometer detector
- evidence for extraterrestrial neutrinos
- conclusions

the sun constructs an accelerator

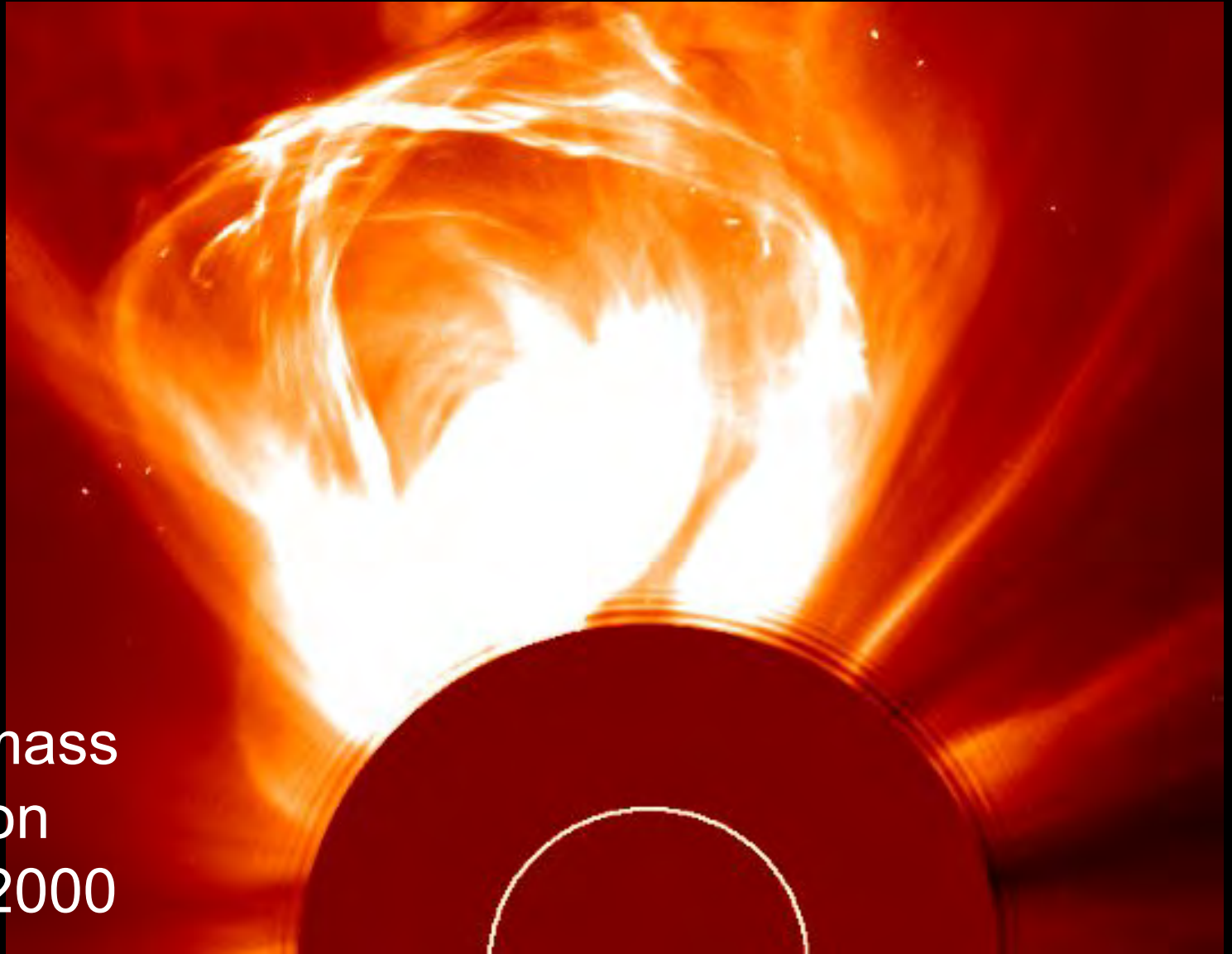

coronal mass
ejection
09 Mar 2000

Hillas formula :

- accelerator must contain the particles

$$R_{gyro} \left(= \frac{E}{vqB} \right) \leq R$$

$$E \leq v qBR$$

- dimensional analysis, difficult to satisfy

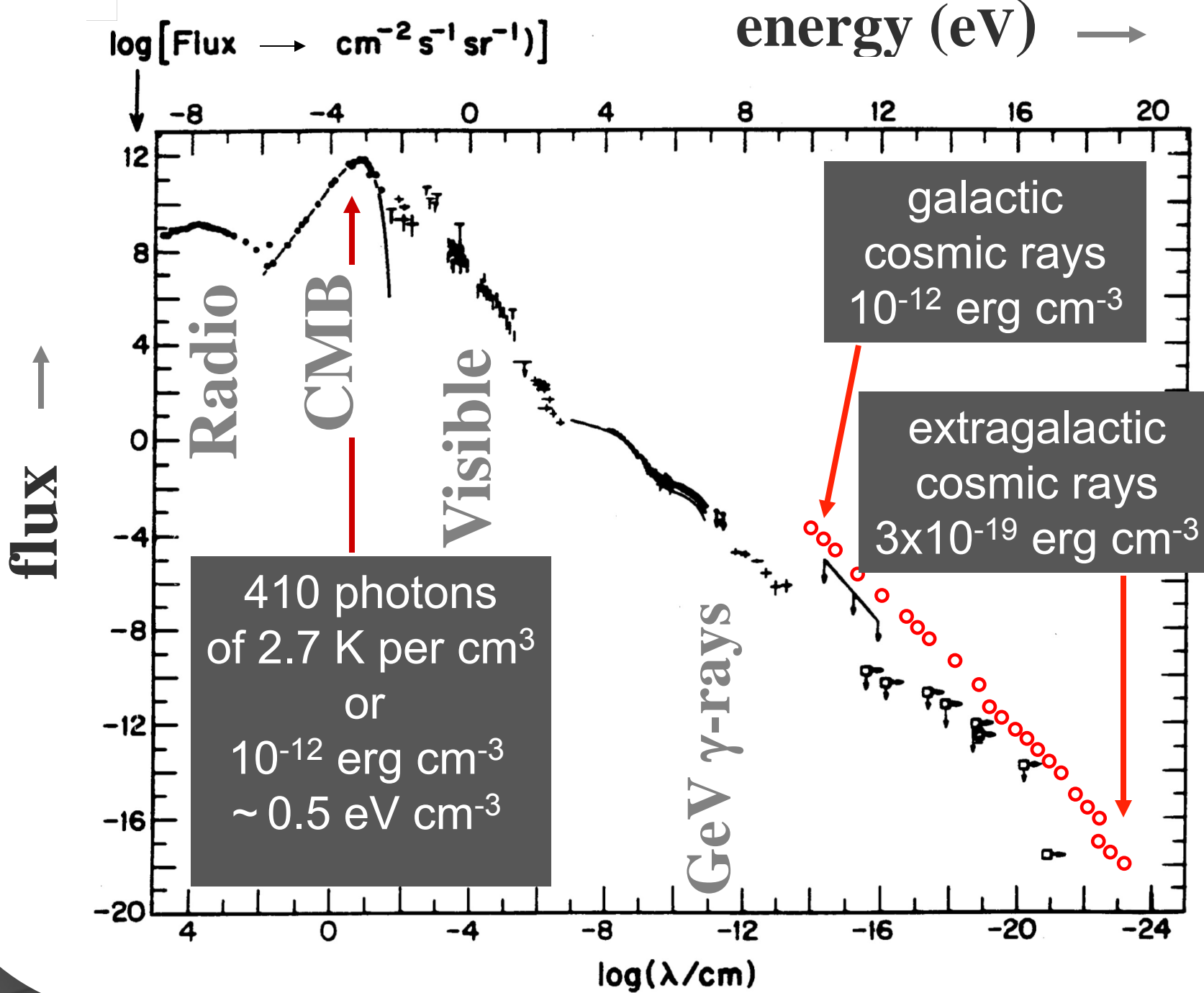

supernova remnants

Chandra
Cassiopeia A

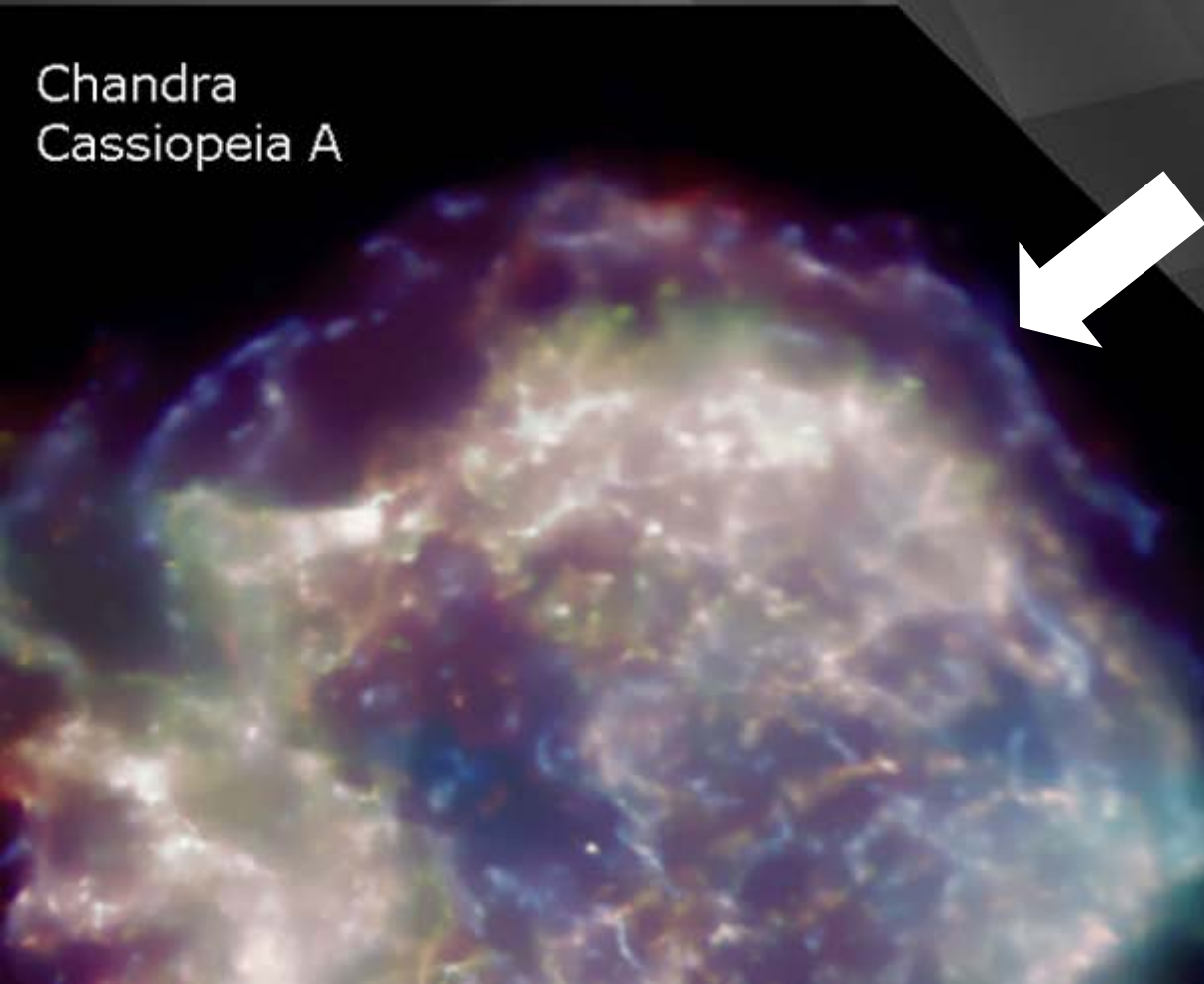

Chandra
SN 1006



neutrinos
from
supernova
remnants :

molecular
clouds in star-
forming
regions where
super-nova
explode: beam
dumps!

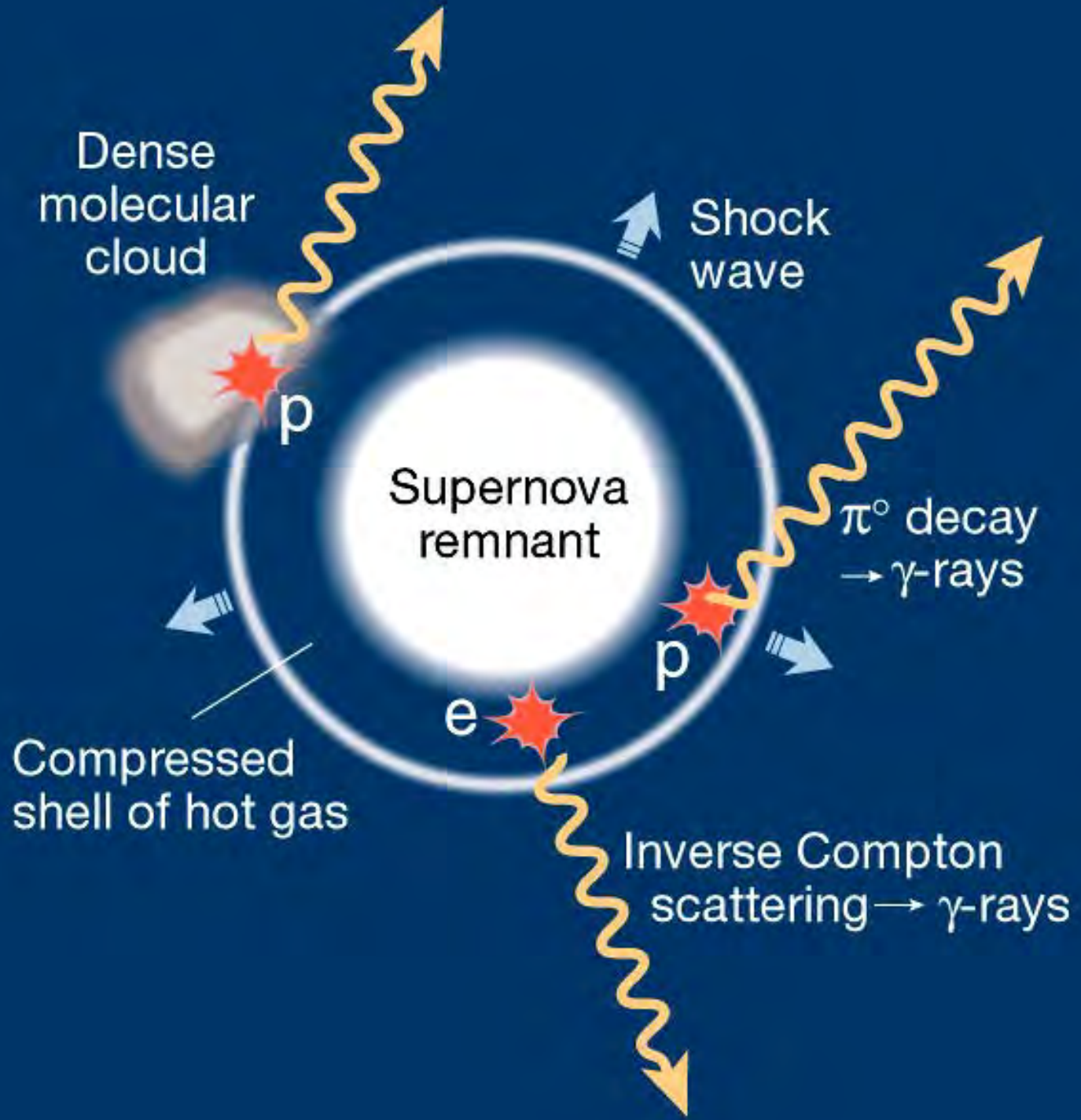

ON SUPER-NOVAE

BY W. BAADE AND F. ZWICKY

MOUNT WILSON OBSERVATORY, CARNEGIE INSTITUTION OF WASHINGTON AND CALIFORNIA INSTITUTE OF TECHNOLOGY, PASADENA

Communicated March 19, 1934

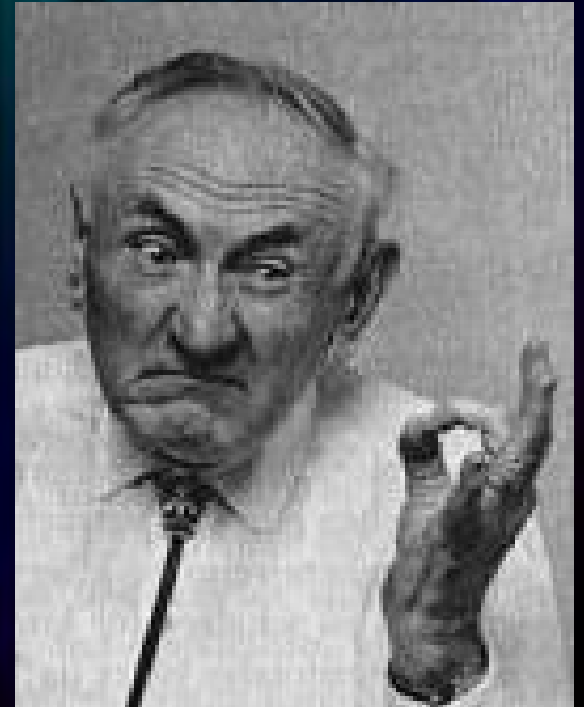
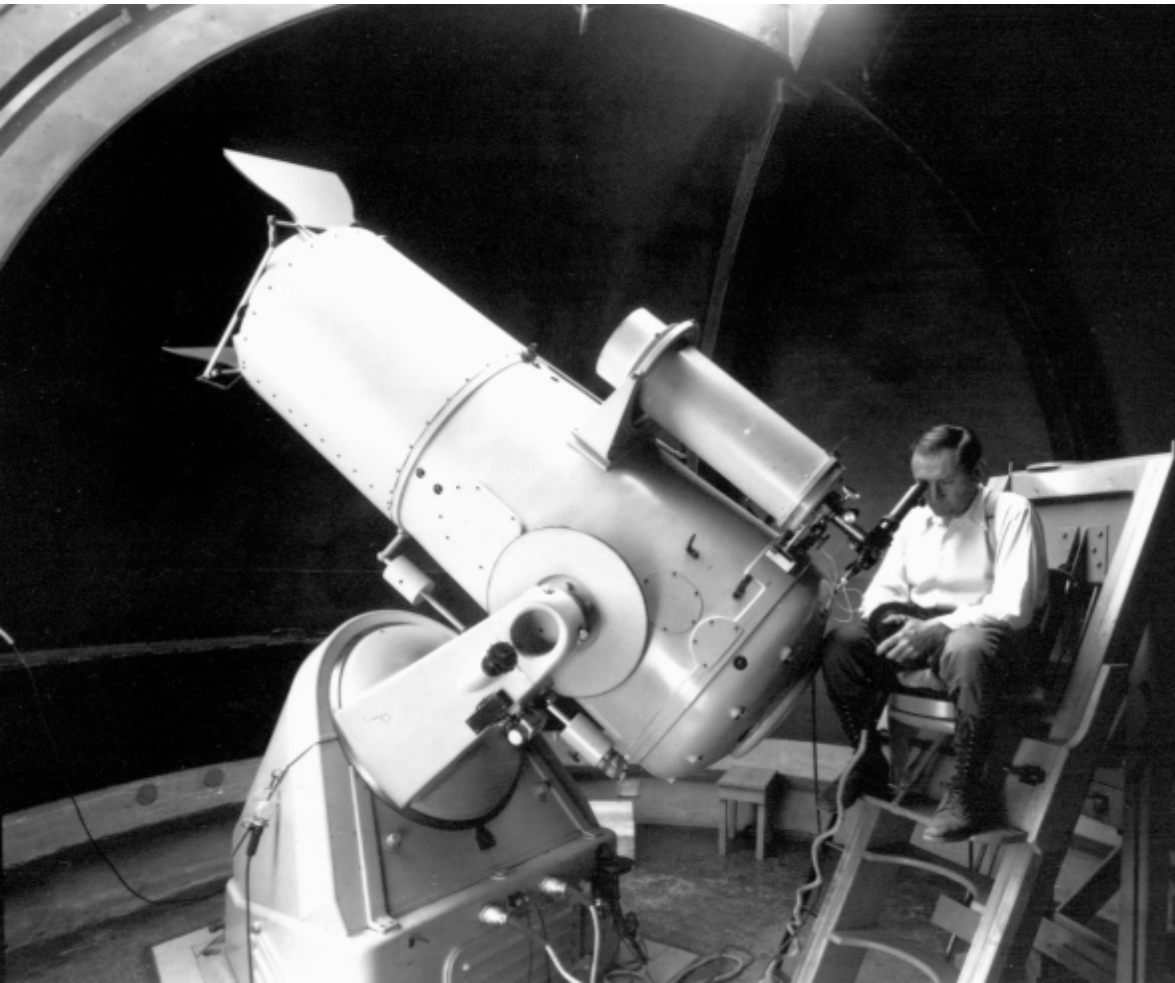

neutral pions
are observed as
gamma rays

charged pions
are observed as
neutrinos

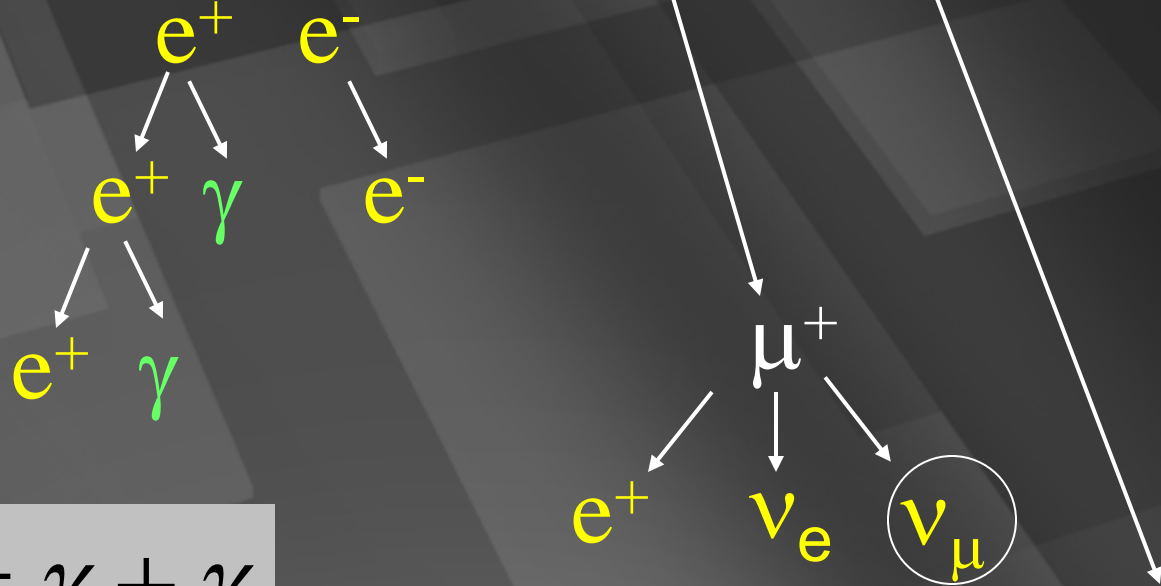
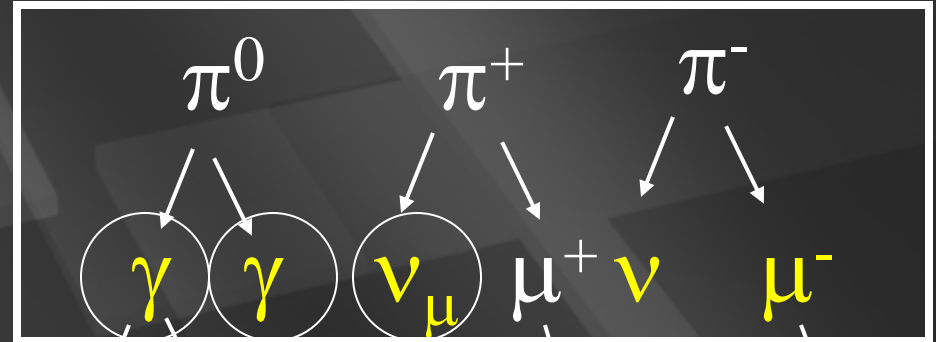

$$\nu_\mu + \bar{\nu}_\mu = \gamma + \gamma$$

supernova remnants

Chandra
Cassiopeia A

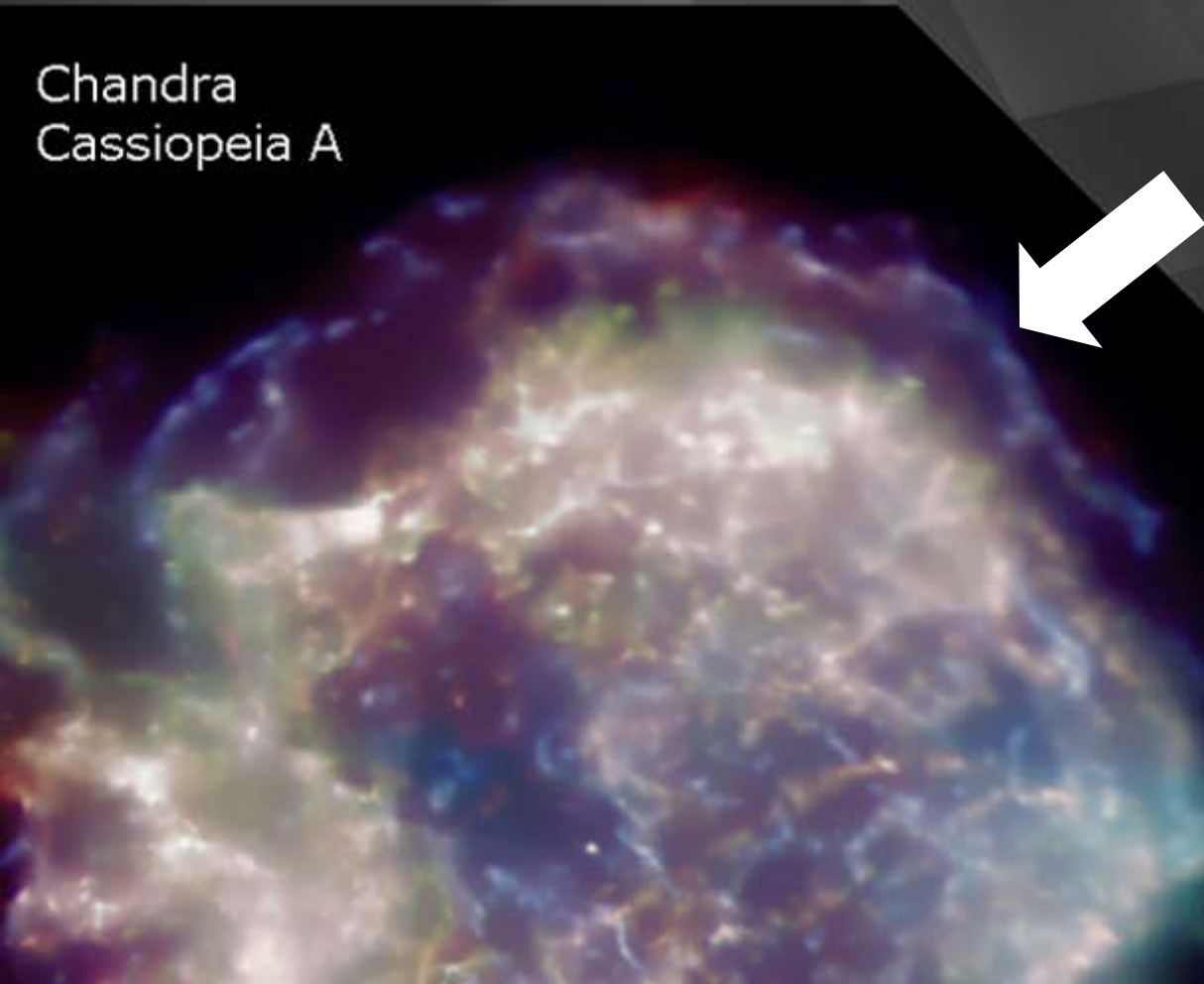

Chandra
SN 1006



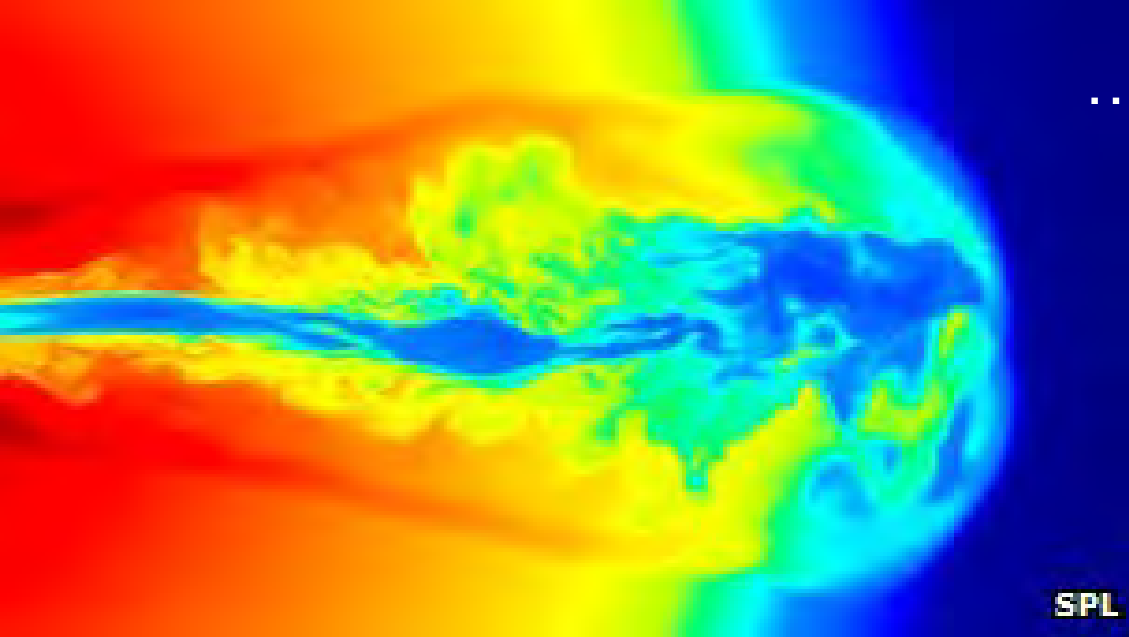

...and if the star collapses to
a black hole...
gamma ray burst

- ✓ happens in seconds
not thousands of year
- ✓ beamed along the spin
axis of the black hole
- ✓ simulation not image

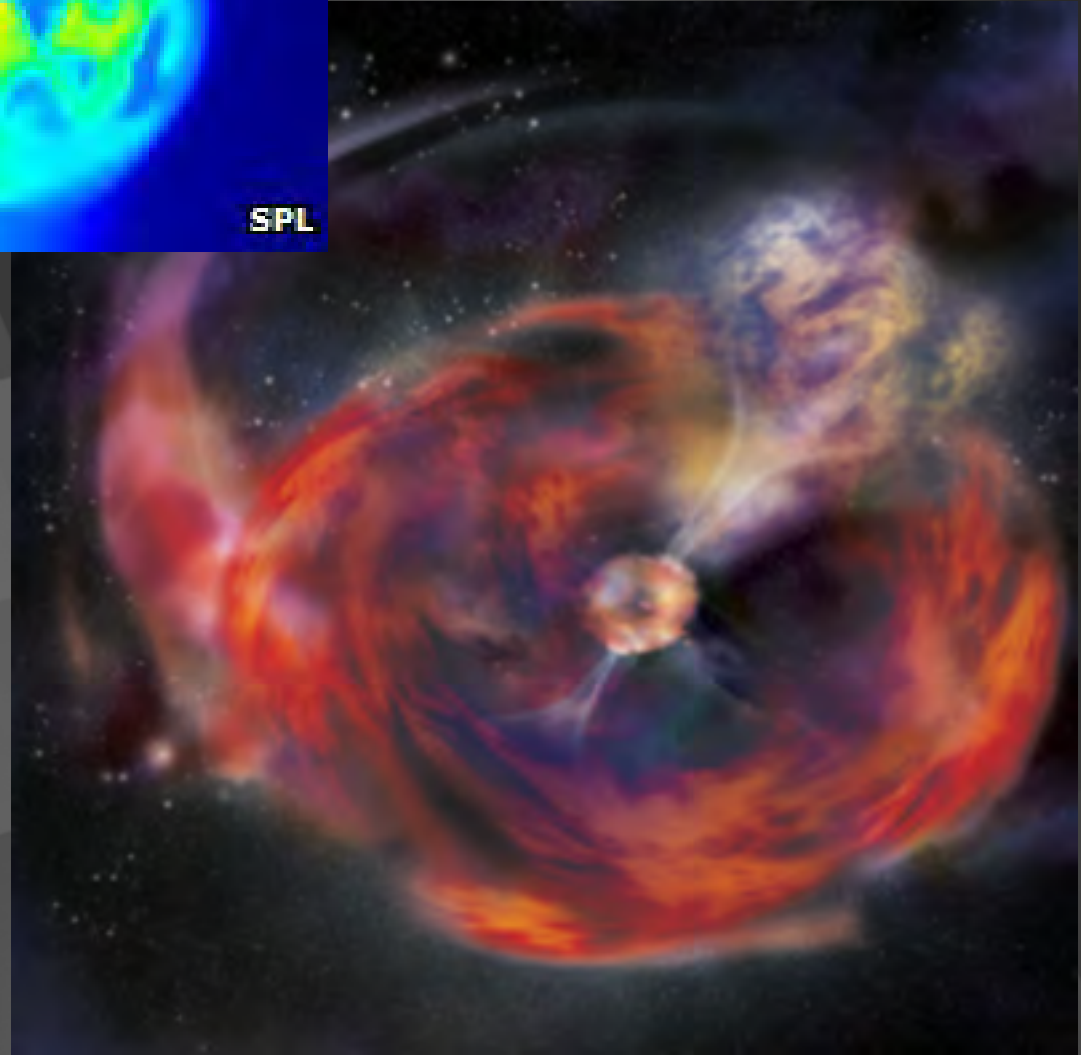

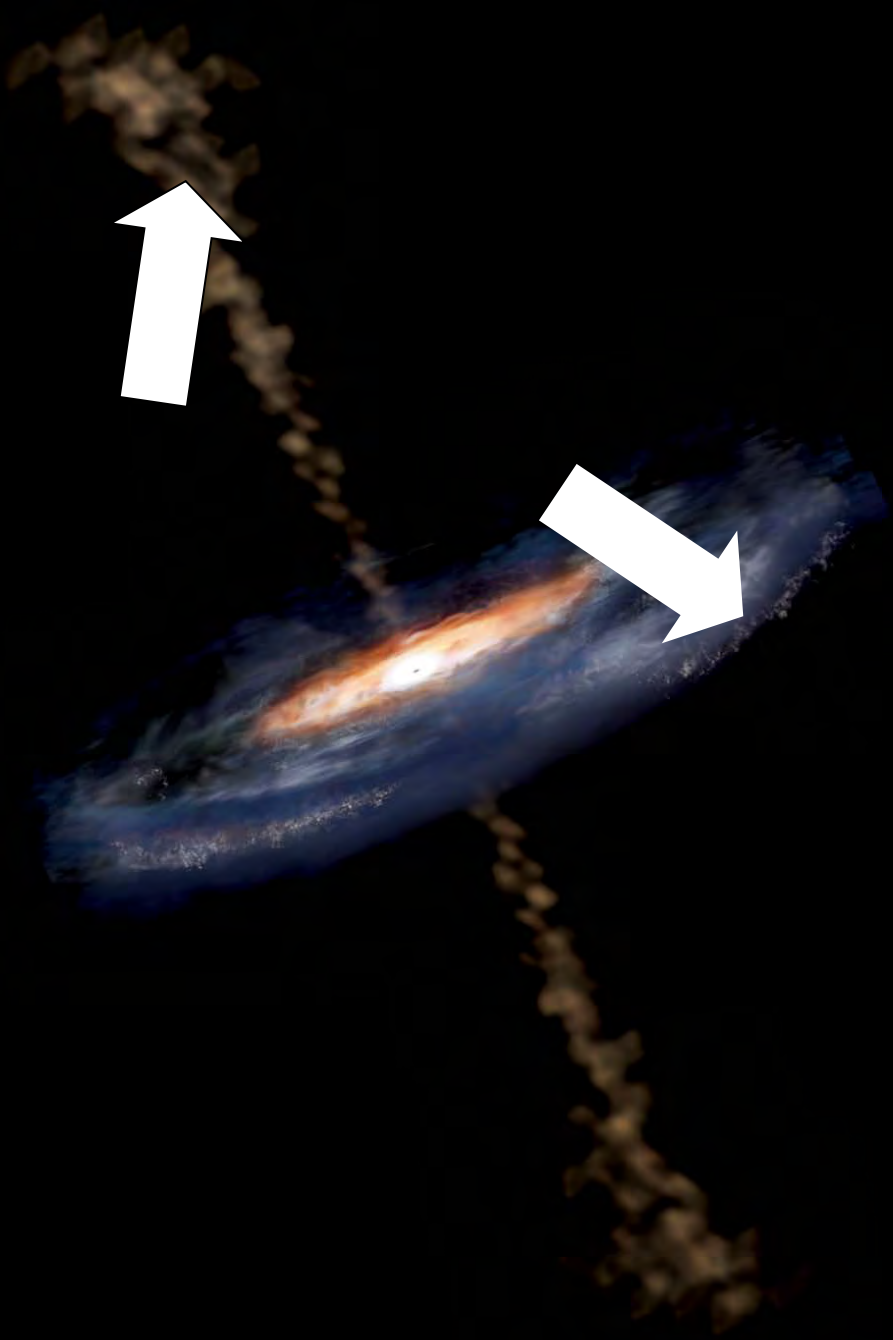

active galaxy

particle flows near
supermassive
black hole

sources accommodating the observed energy budget

Galactic:
supernova
remnants?

extragalactic:
• gamma ray
bursts??
• active
galaxies?

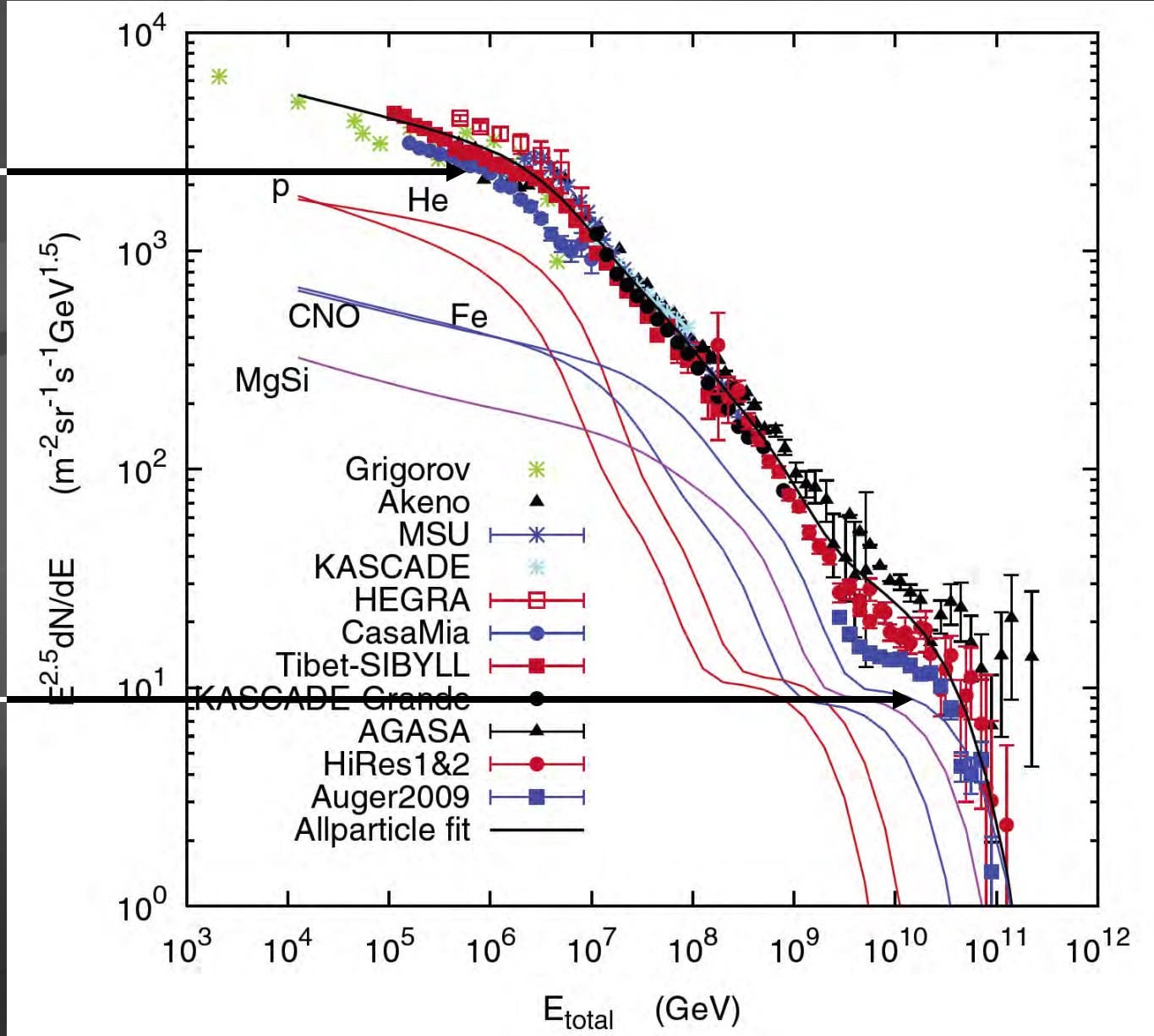

A vertical IceCube detector string is shown on the left side of the slide. It consists of a central cable with several spherical detector modules attached. Each module has a white outer shell and a glowing blue and green inner structure. The string is suspended from the top and extends downwards.

IceCube

francis halzen

- cosmogenic neutrinos
- the energetics of cosmic ray sources
- **neutrinos associated with cosmic rays**
- a cubic kilometer detector
- evidence for extraterrestrial neutrinos
- conclusions

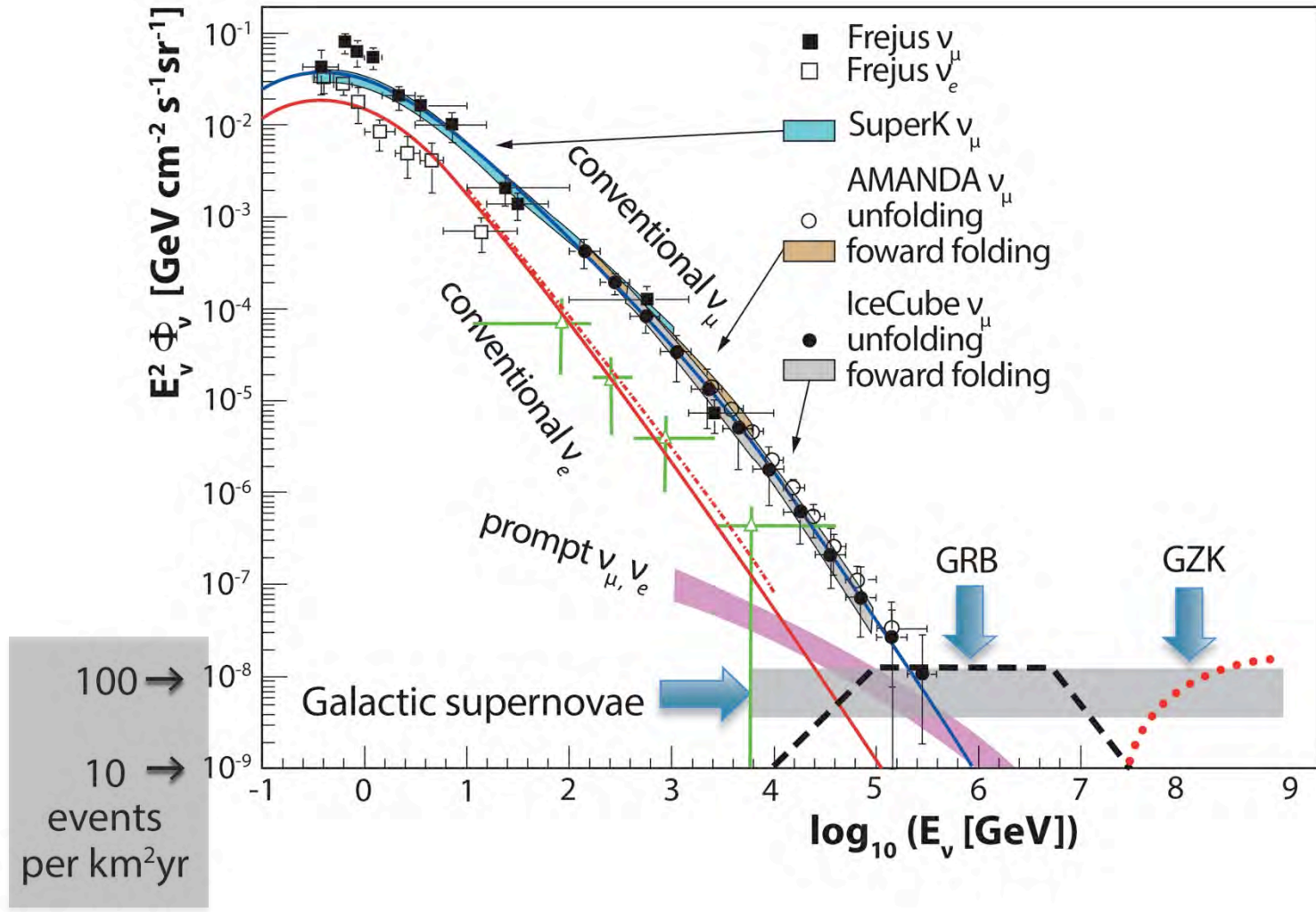

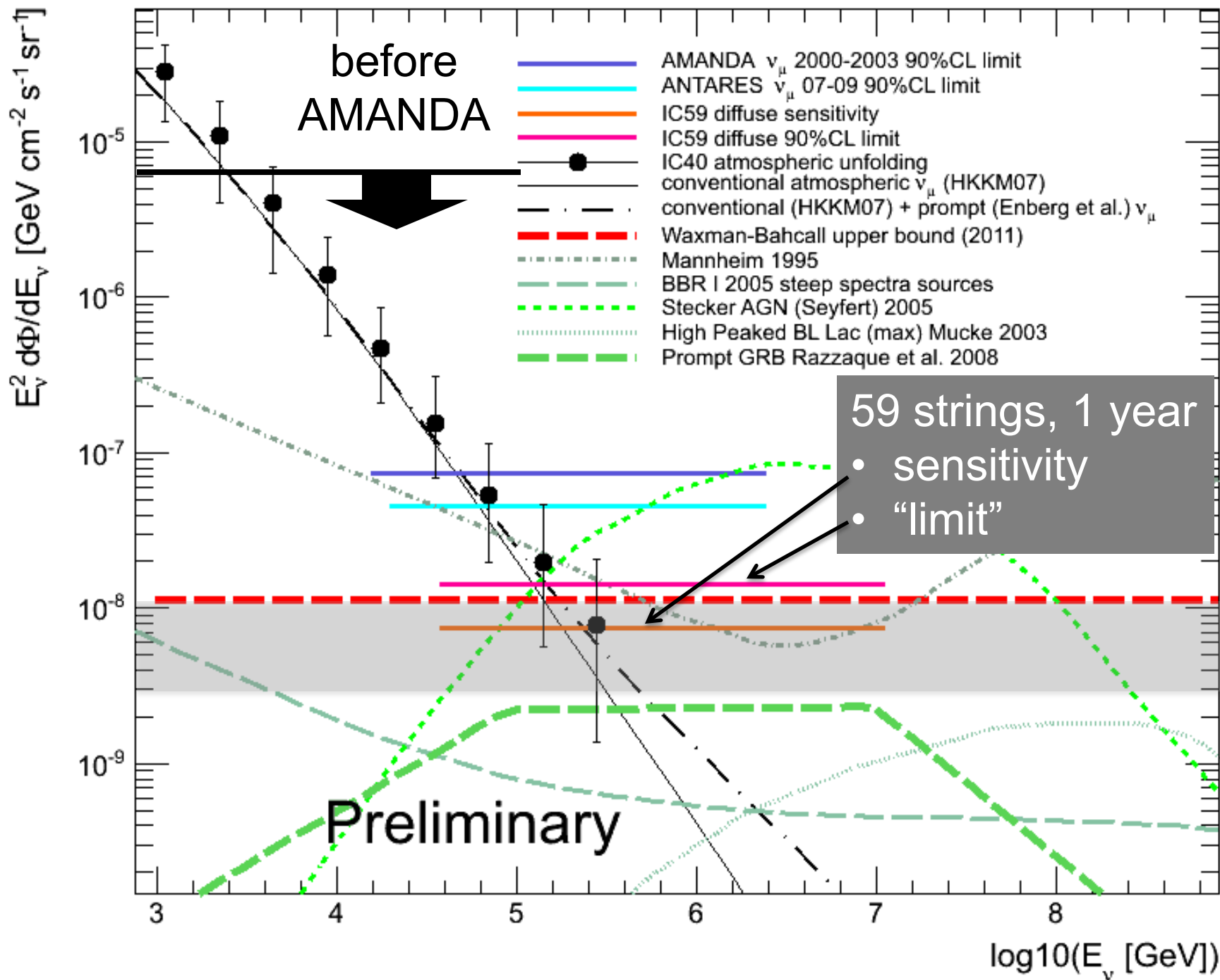

IceCube 59: the last limit ?

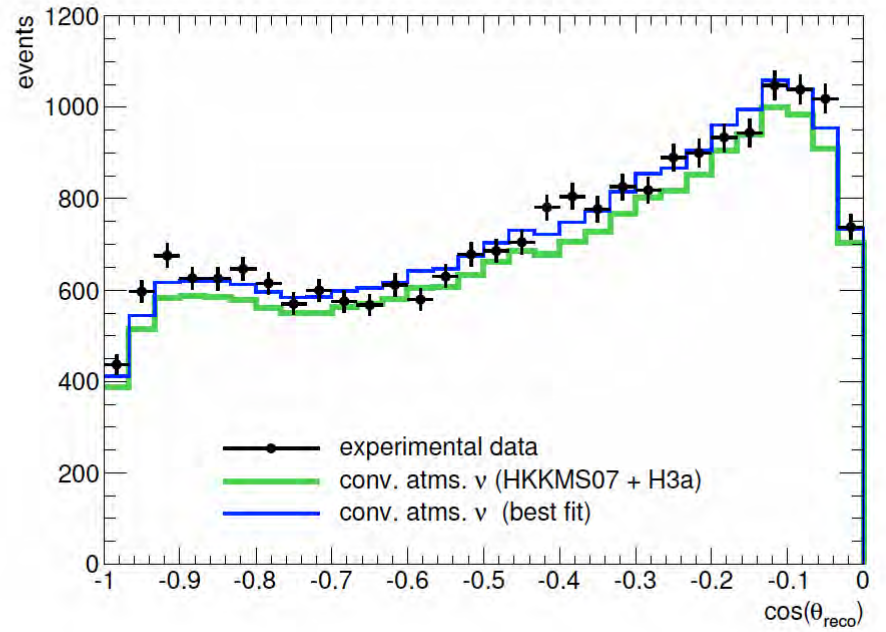
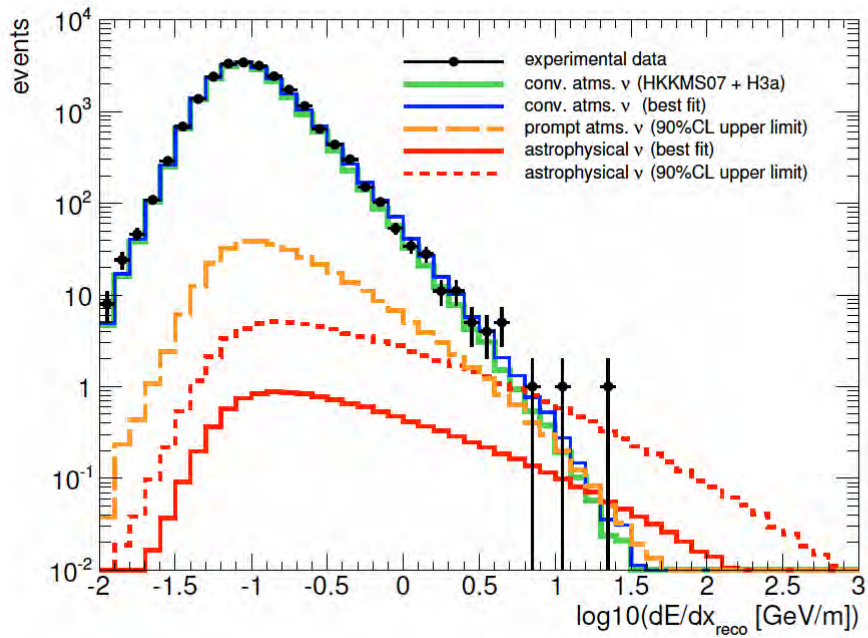

sterile neutrinos?

A vertical IceCube detector string is shown on the left side of the slide. It consists of a central cable with several spherical detector modules attached. Each module has a white outer shell and a glowing green inner core. The string is suspended from the top and extends downwards.

IceCube

francis halzen

- cosmogenic neutrinos
- the energetics of cosmic ray sources
- neutrinos associated with cosmic rays
- **a cubic kilometer detector**
- evidence for extraterrestrial neutrinos
- conclusions

M. Markov
1960

B. Pontecorvo

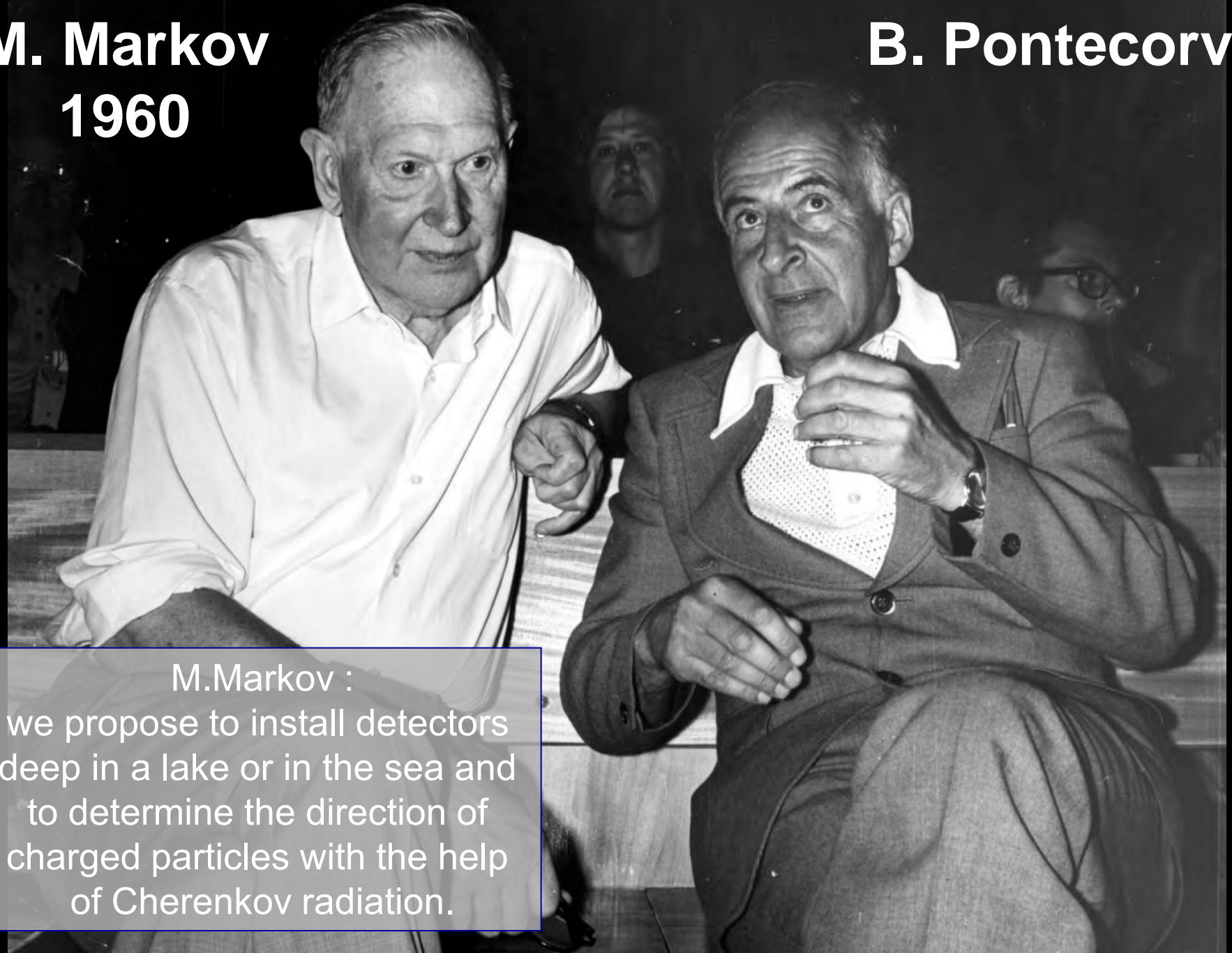

M.Markov :
we propose to install detectors
deep in a lake or in the sea and
to determine the direction of
charged particles with the help
of Cherenkov radiation.

- shielded and optically transparent medium

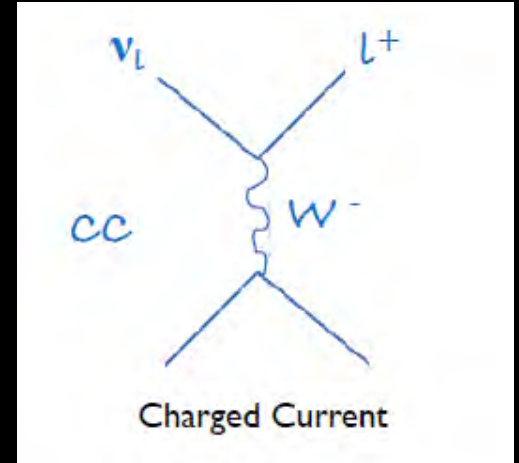
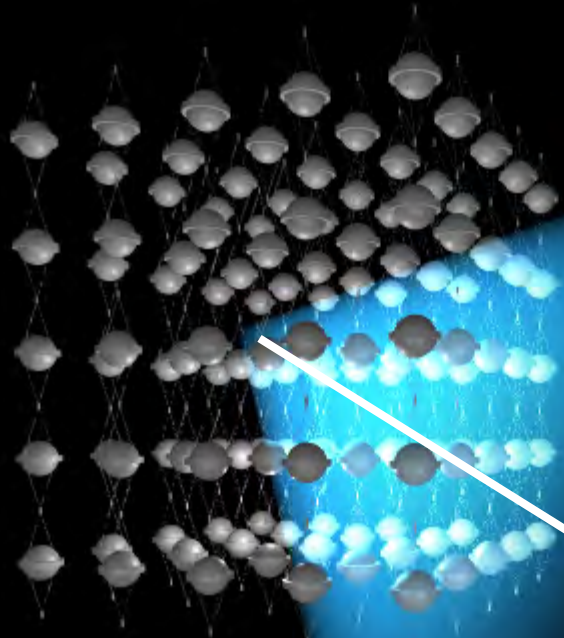

μ

ν

- lattice of photomultipliers

photomultiplier
tube



93 TeV muon

```
Type: NuMu  
E(GeV): 9.30e+04  
Zen: 40.45 deg  
Azi: 192.12 deg  
NTrack: 1/1 shown, min E(GeV) == 93026.46  
NCasc: 100/427 shown, min E(GeV) == 7.99
```

energy measurement ($> 1 \text{ TeV}$)

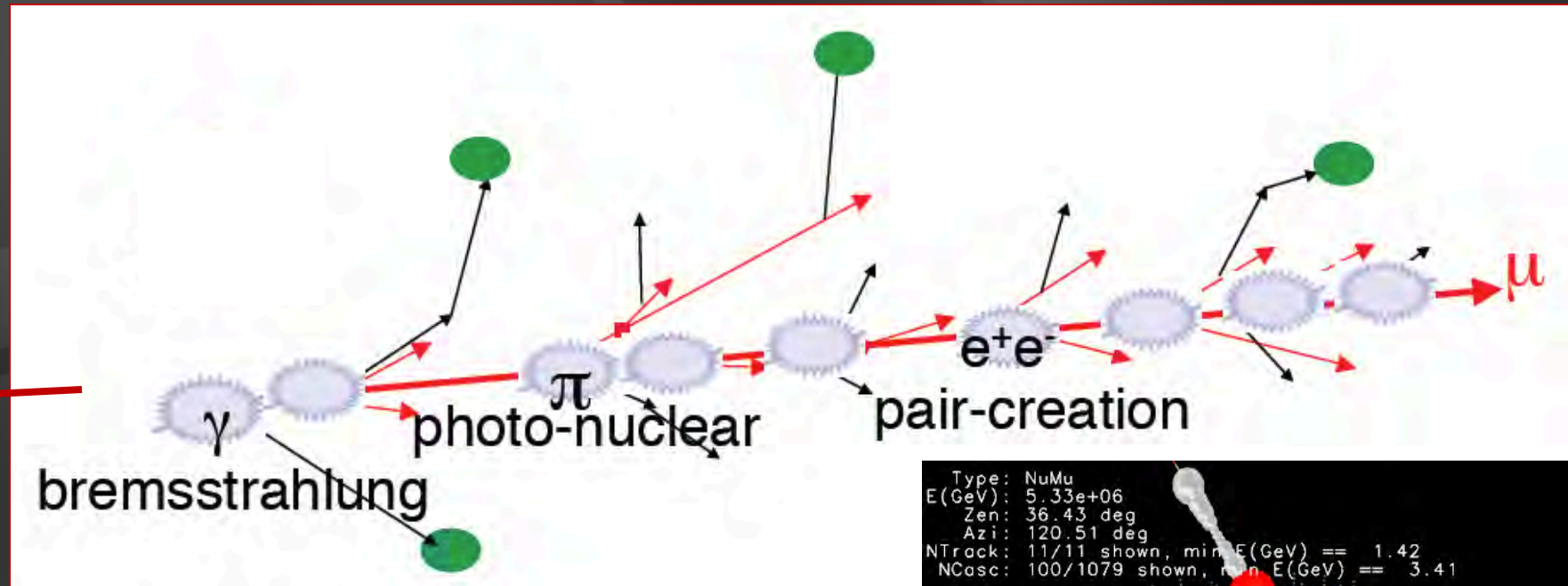

```
Type: NuMu  
E(GeV): 5.33e+06  
Zen: 36.43 deg  
Azi: 120.51 deg  
NTrack: 11/11 shown, min E(GeV) == 1.42  
NCasc: 100/1079 shown, min E(GeV) == 3.41
```

convert the amount of light emitted to measurement of the muon energy (number of optical modules, number of photons, dE/dx , ...)

Differential Energy Reconstruction of 5 PeV Muon in IC-86

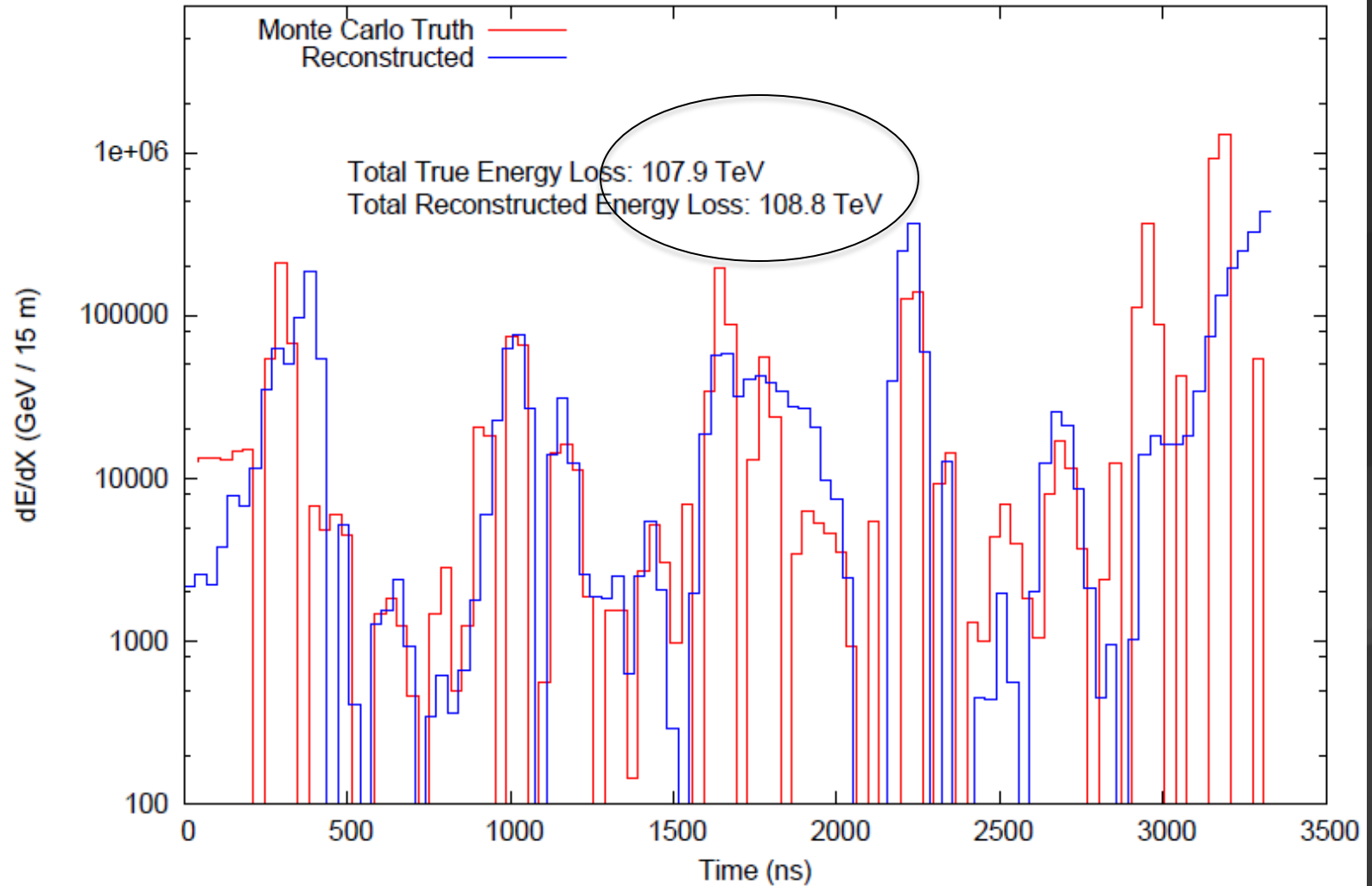

improving angular and energy resolution



why did it take so long ?

south pole 2000

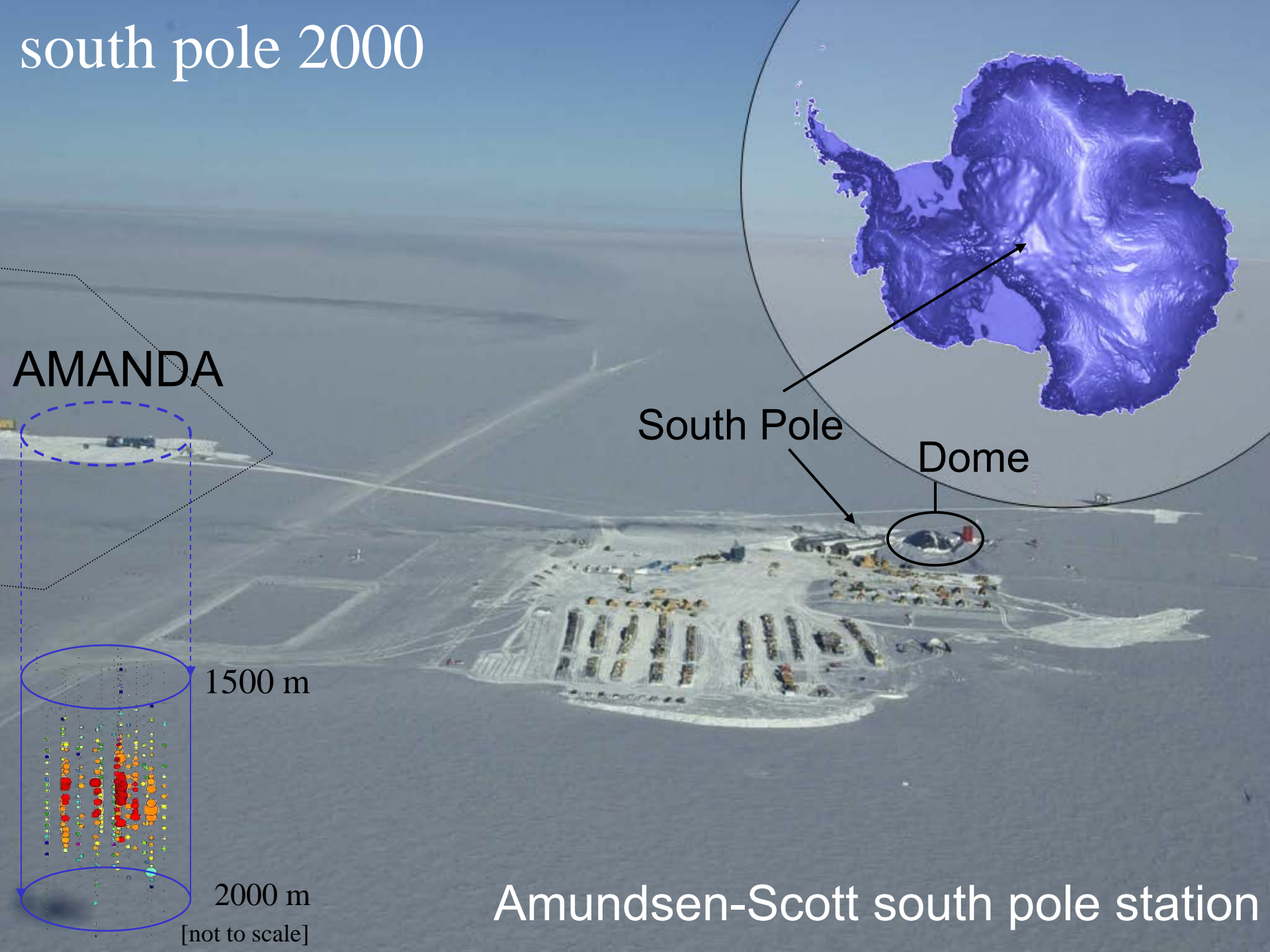

AMANDA

South Pole

Dome

1500 m

2000 m

[not to scale]

Amundsen-Scott south pole station

IceCube / Deep Core

- 5160 optical sensors between 1.5 ~ 2.5 km
- 10 GeV to infinity
- < 0.5 degree on-line
< 0.3 degree off line for muons
(10~15 degrees for showers)
- < 15% energy resolution

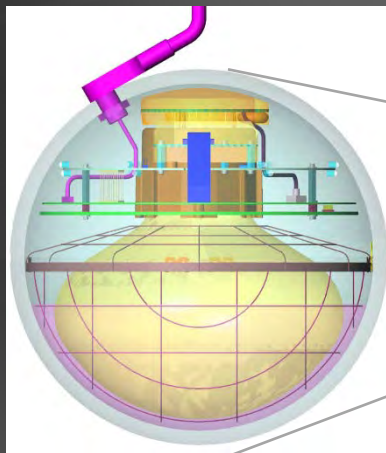

Digital Optical Module (DOM)

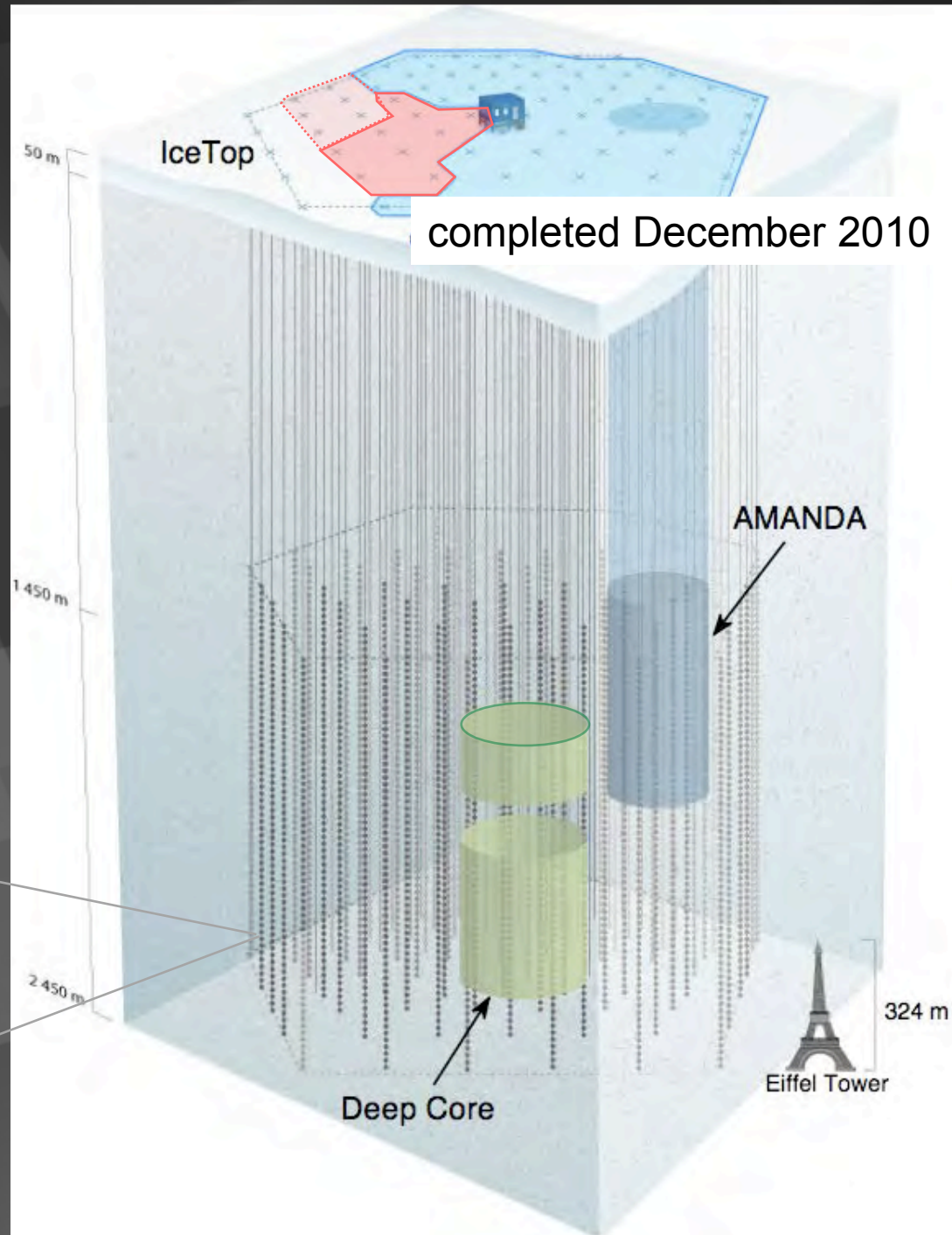

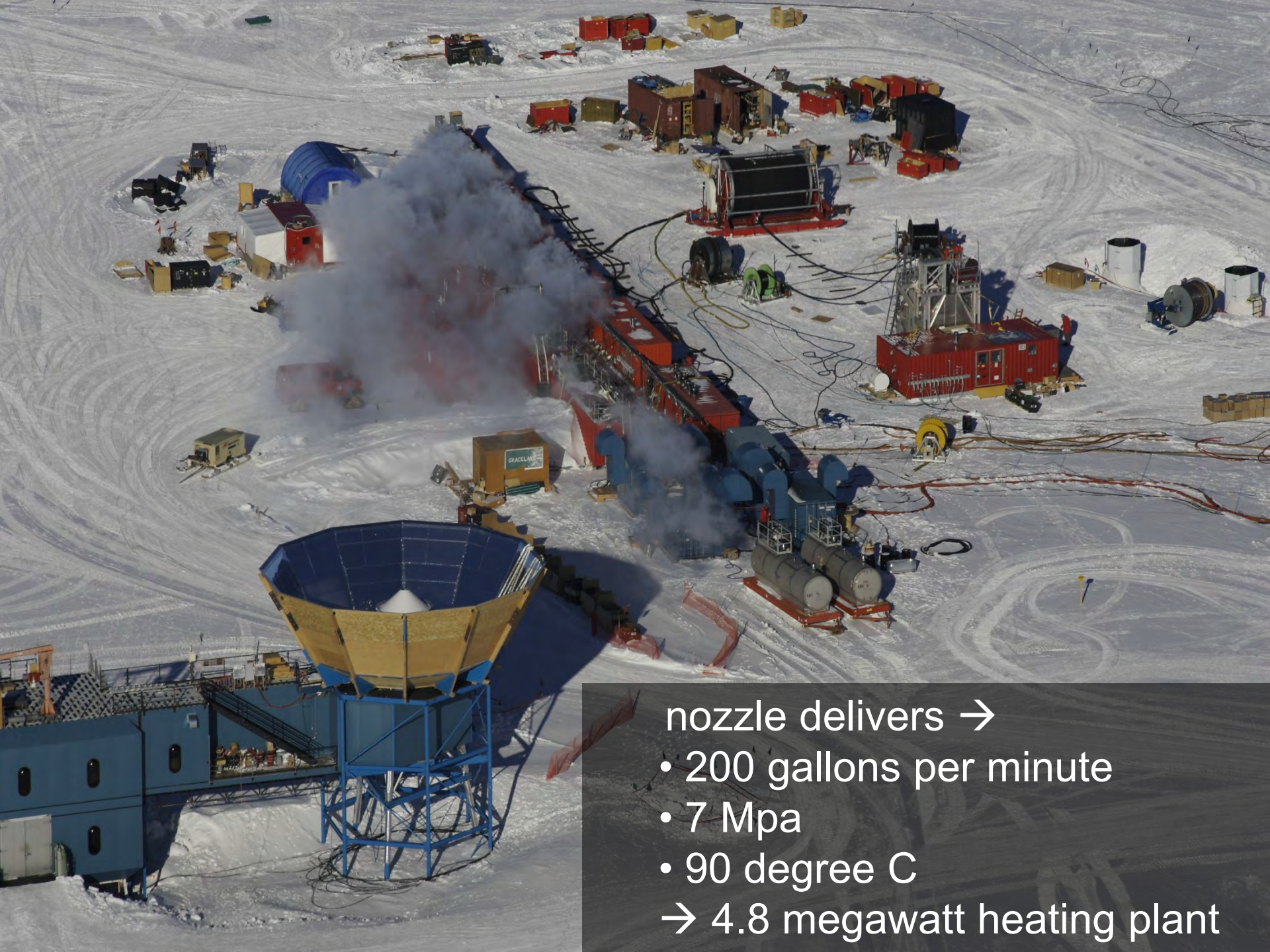

nozzle delivers →

- 200 gallons per minute
- 7 Mpa
- 90 degree C

→ 4.8 megawatt heating plant

drilling and deployment



2 days per hole
3.5 cm/second



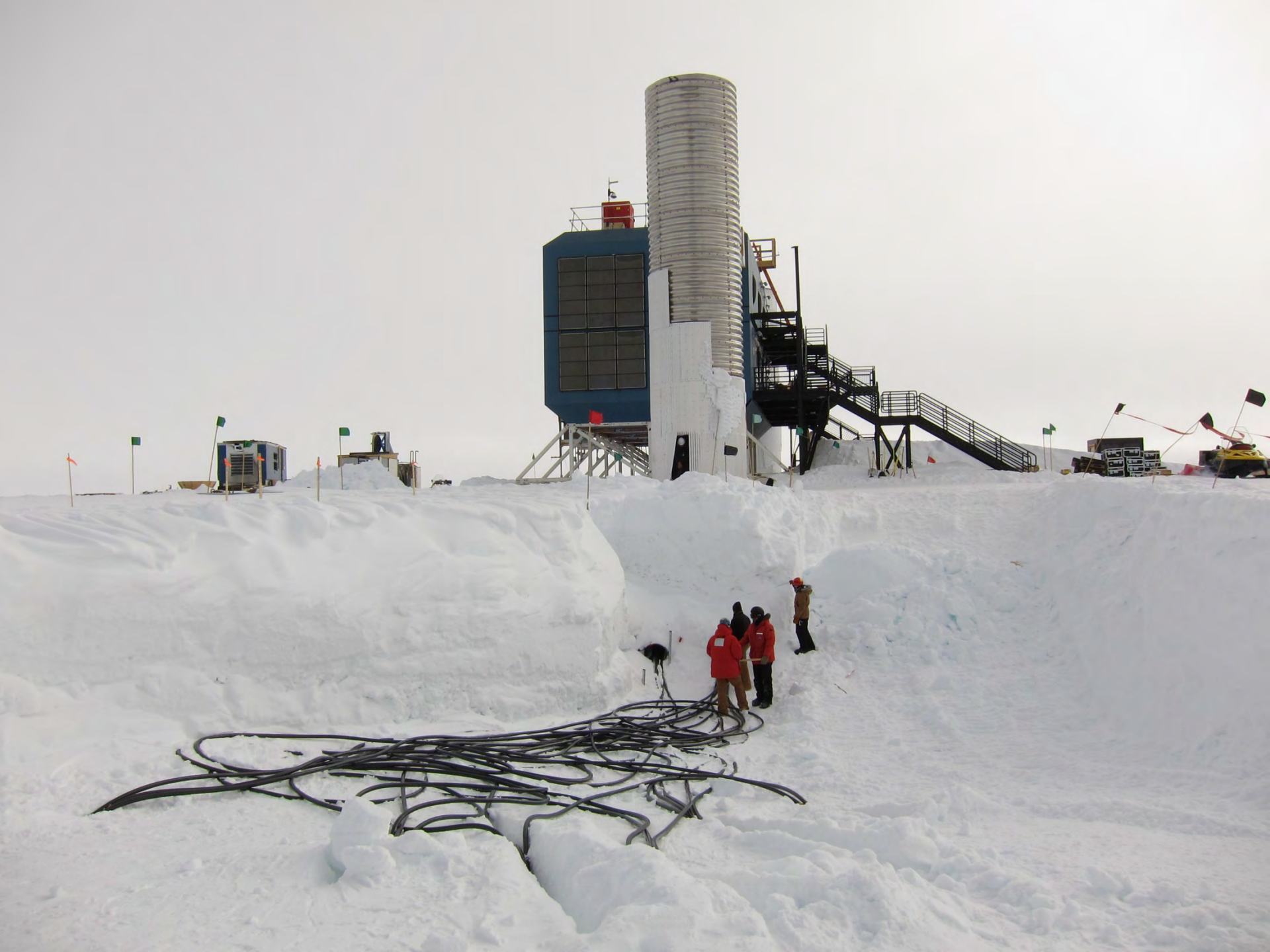

architecture of independent DOMs

LED
flasher
board

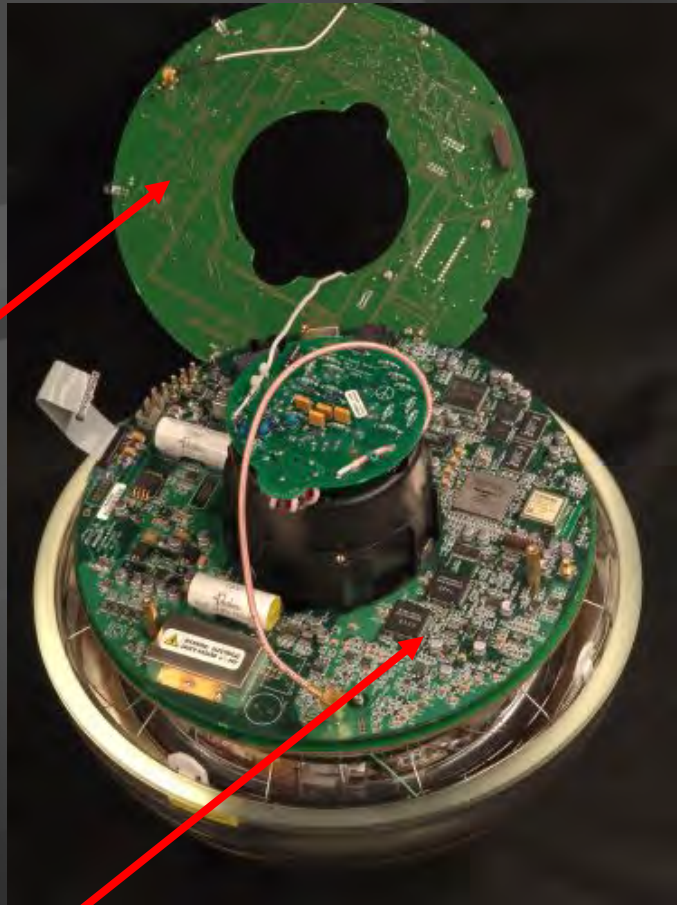

main
board

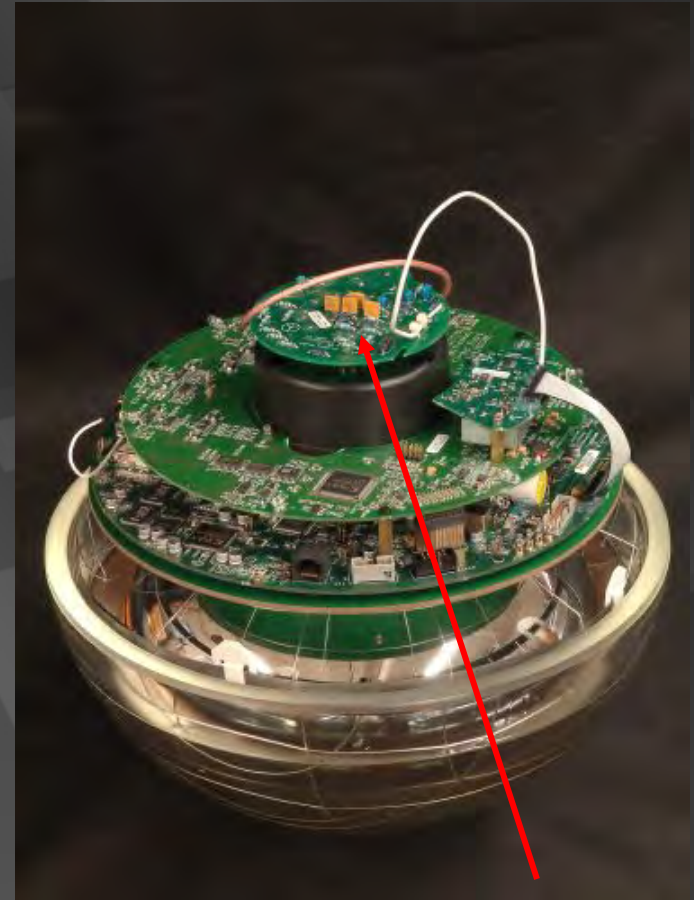

HV board

Digital Optical Module (DOM)

... each DOM independently collects light signals like this...

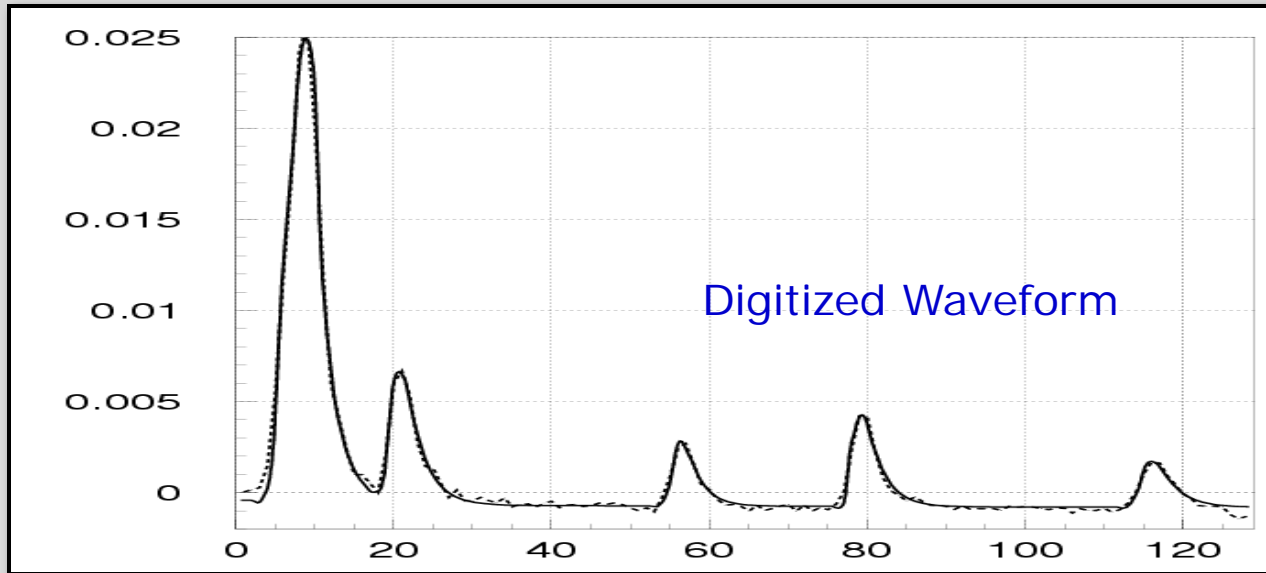

...time stamps them with 2 nanoseconds precision and sends them to a computer that sorts them into muon and neutrino events...

Type: RPlus
E(GeV): 1.42e+04
Zen: 17.37 deg
Azi: 253.08 deg
NTrack: 990/1826 shown, min E(GeV) == 1184.28
NCasc: 100/14225 shown, min E(GeV) == 0.94

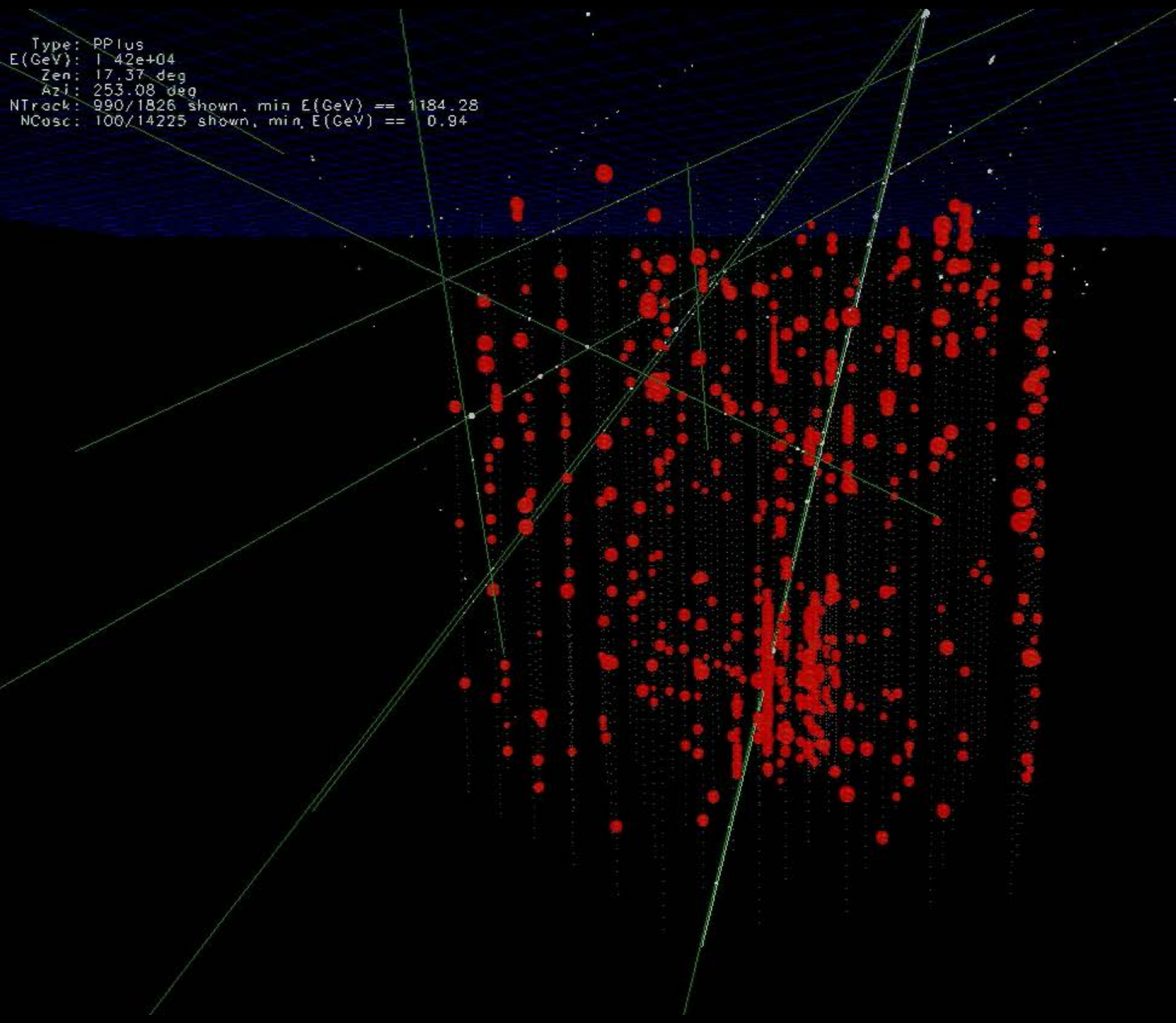

... you looked at 10msec of data !

muons detected per year:

- atmospheric* μ $\sim 10^{11}$
- atmospheric** $\nu \rightarrow \mu$ $\sim 10^5$
- cosmic $\nu \rightarrow \mu$ ~ 10

* 2700 per second

** 1 every 6 minutes

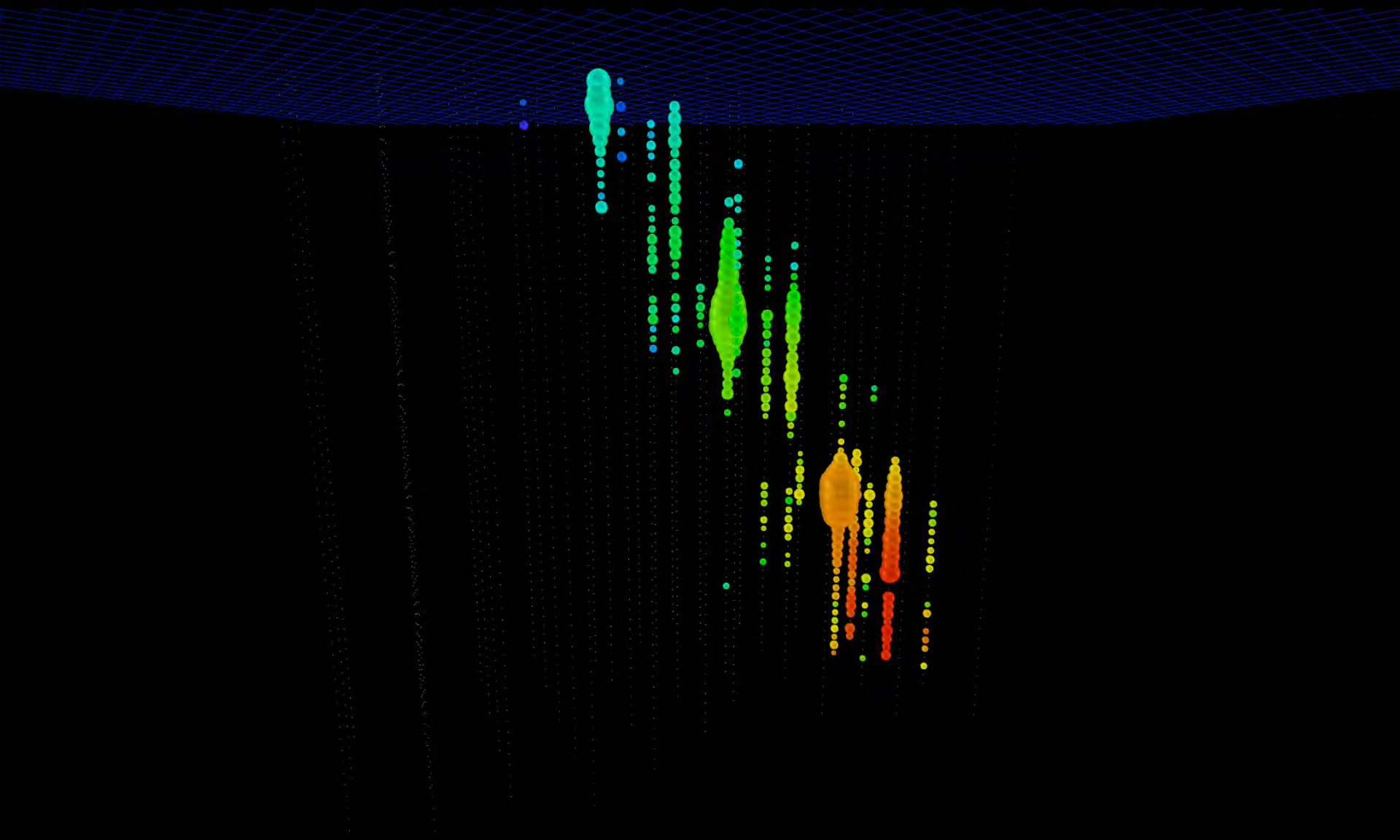

Run 113641 Event 33553254 [0ns, 16748ns]

A vertical IceCube detector string is shown on the left side of the slide. It consists of a central cable with several spherical detector modules attached. Each module has a white outer shell and a glowing green inner core. The string is suspended by thin wires from a dark, curved structure at the top.

IceCube

francis halzen

- cosmogenic neutrinos
- the energetics of cosmic ray sources
- neutrinos associated with cosmic rays
- a cubic kilometer detector
- evidence for extraterrestrial neutrinos
- conclusions

Neutrino Skymaps

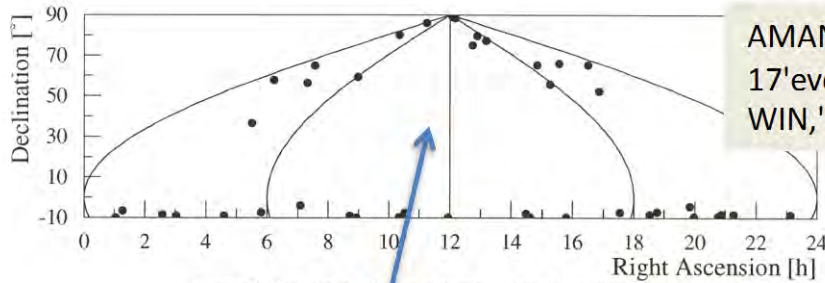

AMANDA 10'
17 events'
WIN, '1999'

Figure 2: Sky plot of all events that pass level 4 quality cuts.

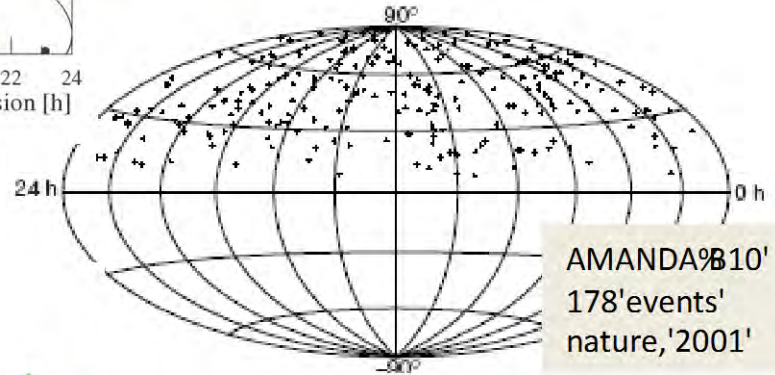

AMANDA 10'
178 events'
nature, '2001'

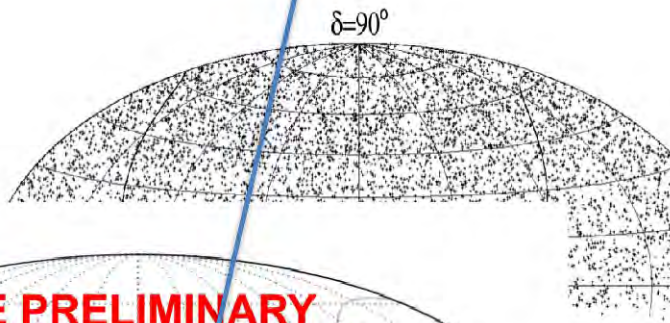

Atm. neutrinos

Atm. muons

ICECUBE PRELIMINARY

* All p-values are post-trial

shower events
p-value = 8%

all events
p-value = 80%

28 events

Equatorial

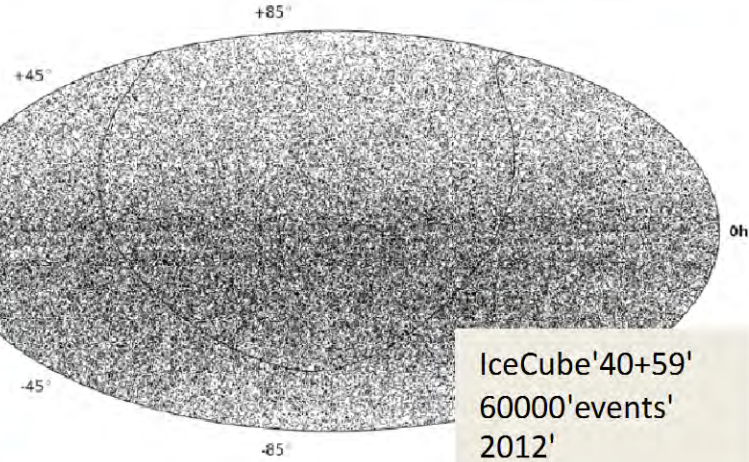
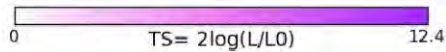

IceCube 40+59'
60000 events'
2012'

- cosmic neutrinos: energy > 100 TeV
- atmospheric background: 1~2 events per year

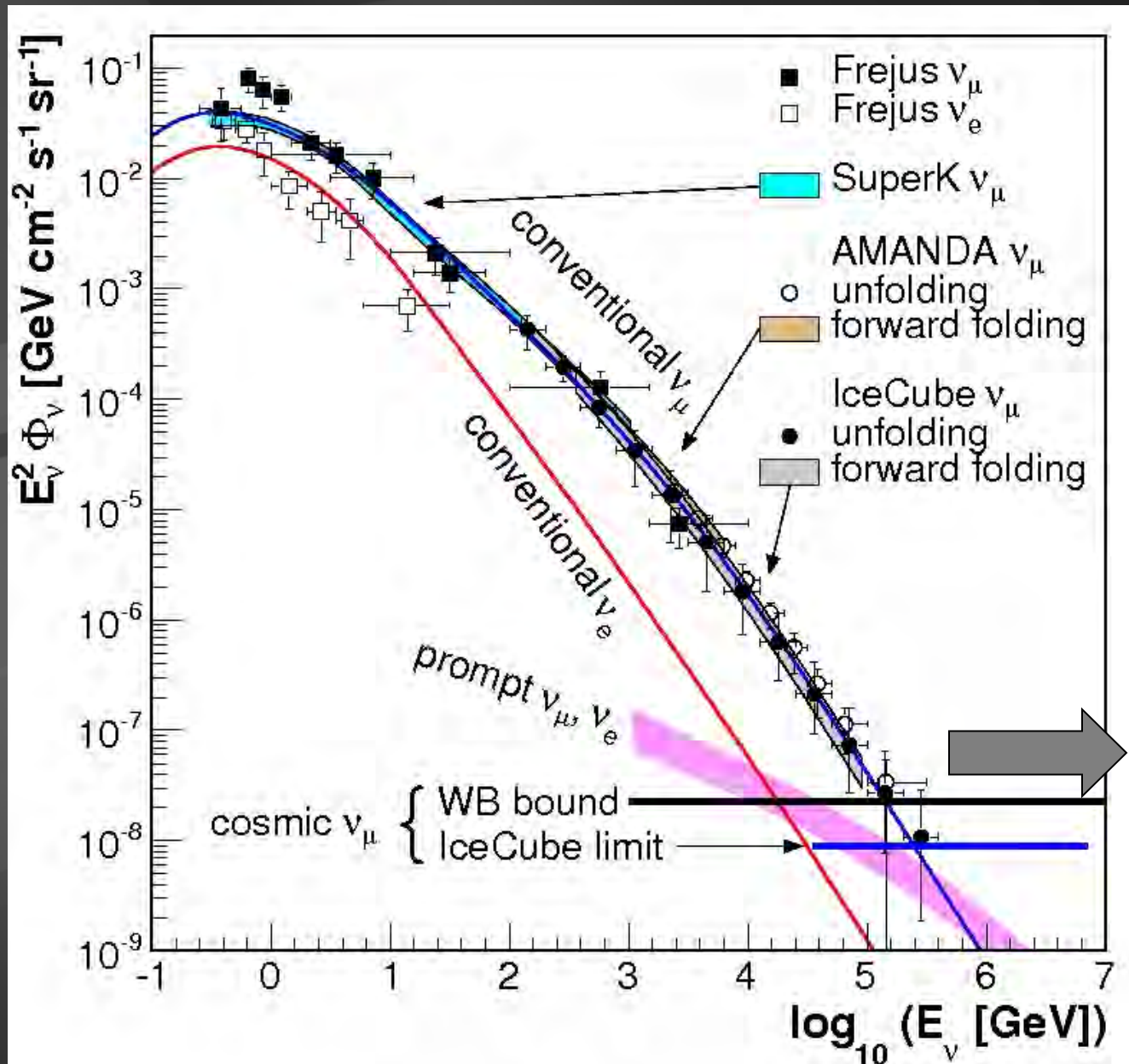

atmospheric neutrino spectrum

cosmic rays interact with the
microwave background

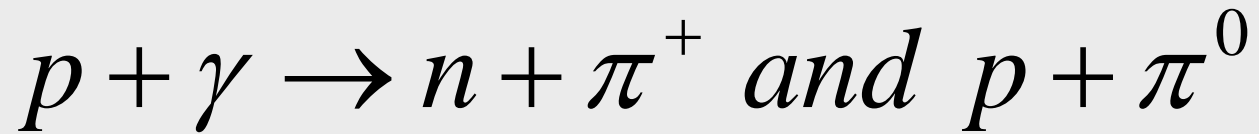

cosmic rays disappear, neutrinos with
EeV (10^{18} eV) energy appear

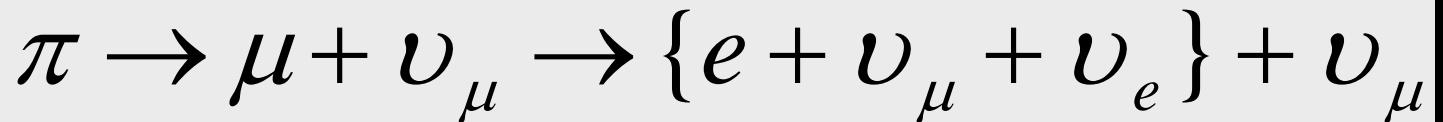

1 event per cubic kilometer per year
...but it points at its source

GZK neutrinos: > 41,000 photons near the horizon

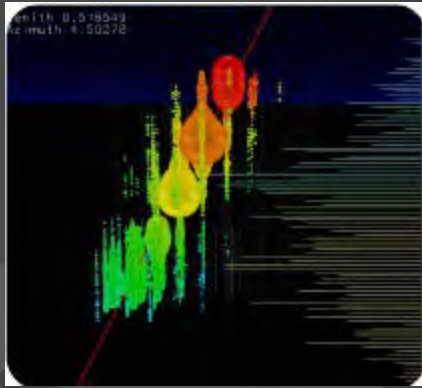

number of
channels
> 300

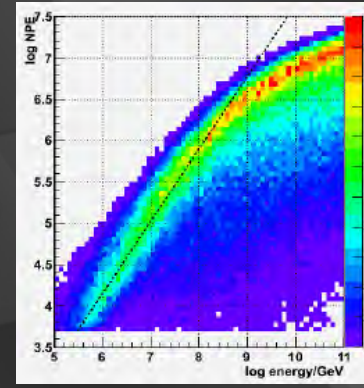
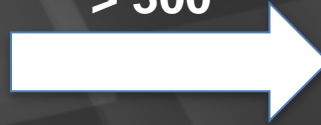

Energy of incoming particle \propto Energy-losses in detector \propto number of photo electrons (NPE)

- Optimization based MC and MC verification based on 10% experimental 'burn' sample

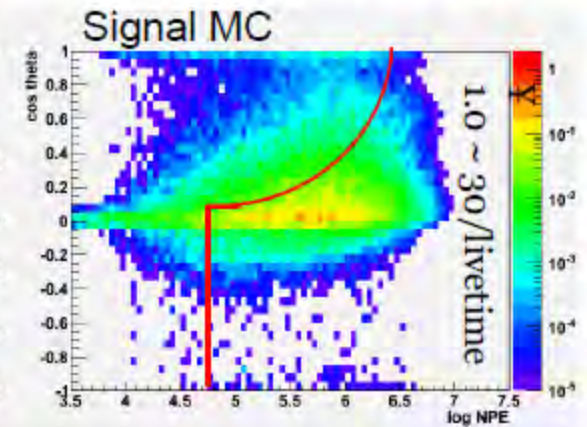
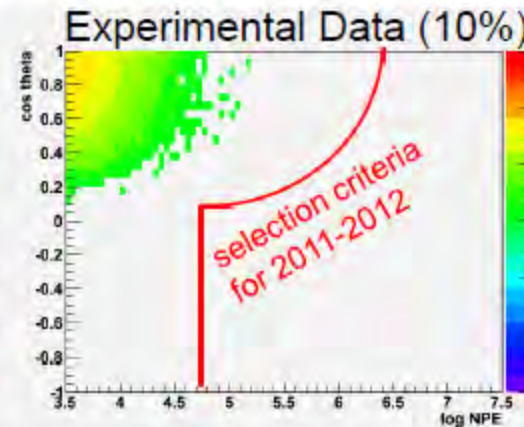
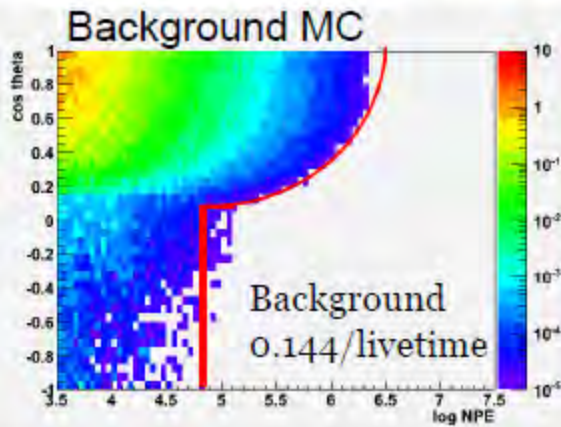

unblinding: 2 events in the signal region



tracks and showers

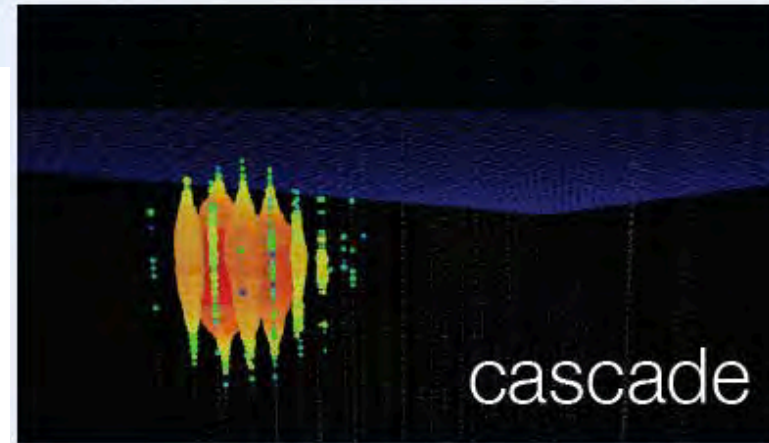
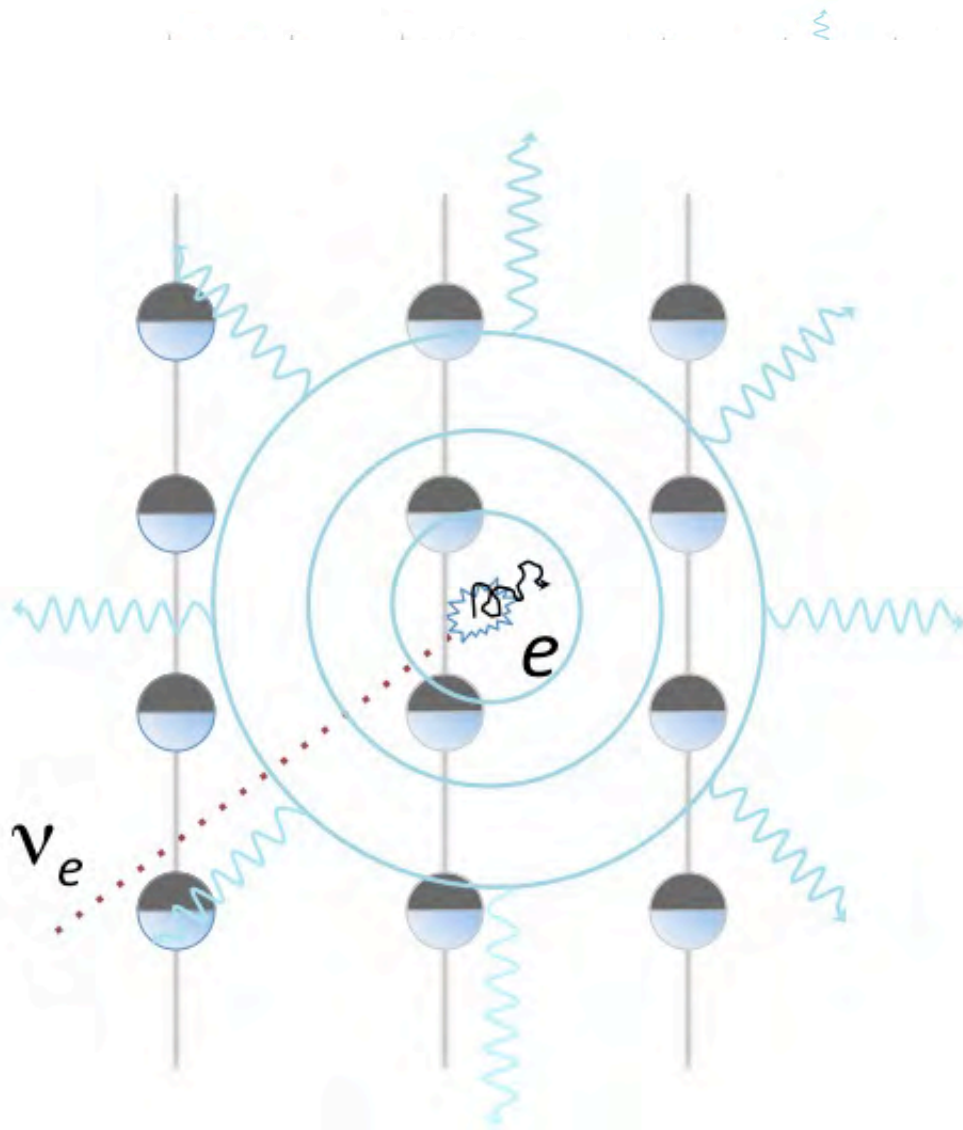

mostly showers ✓

PeV showers:

- volume $\sim 5 \text{ m}^3$
- isotropic after 25~ 50 m

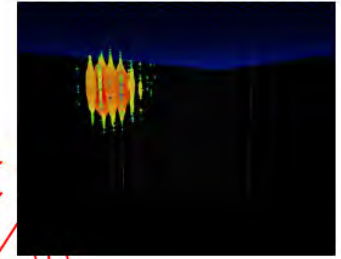
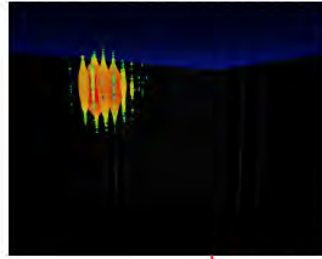

	Charged Current ($W^{+/-}$)	Neutral Current (Z^0)
ν_e	$\nu_e + N \rightarrow e^- + X$	$\nu_e + N \rightarrow \nu_e + X$
ν_μ	$\nu_\mu + N \rightarrow \mu^- + X$	$\nu_\mu + N \rightarrow \nu_\mu + X$
ν_τ	$\nu_\tau + N \rightarrow \tau^- + X$	$\nu_\tau + N \rightarrow \nu_\tau + X$

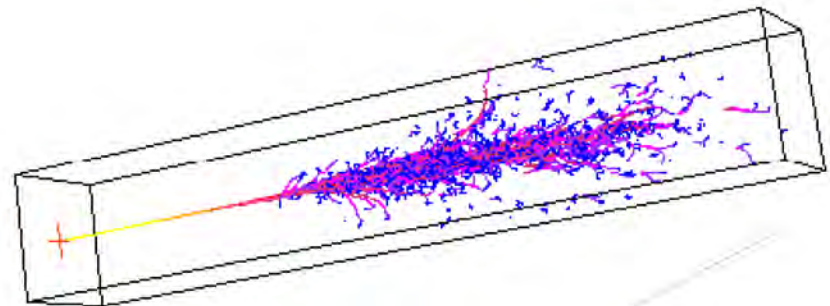
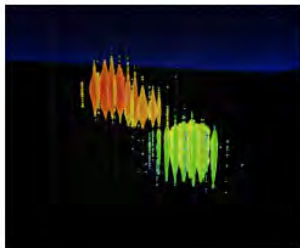
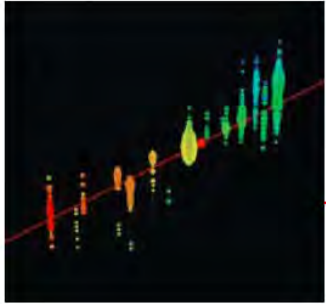



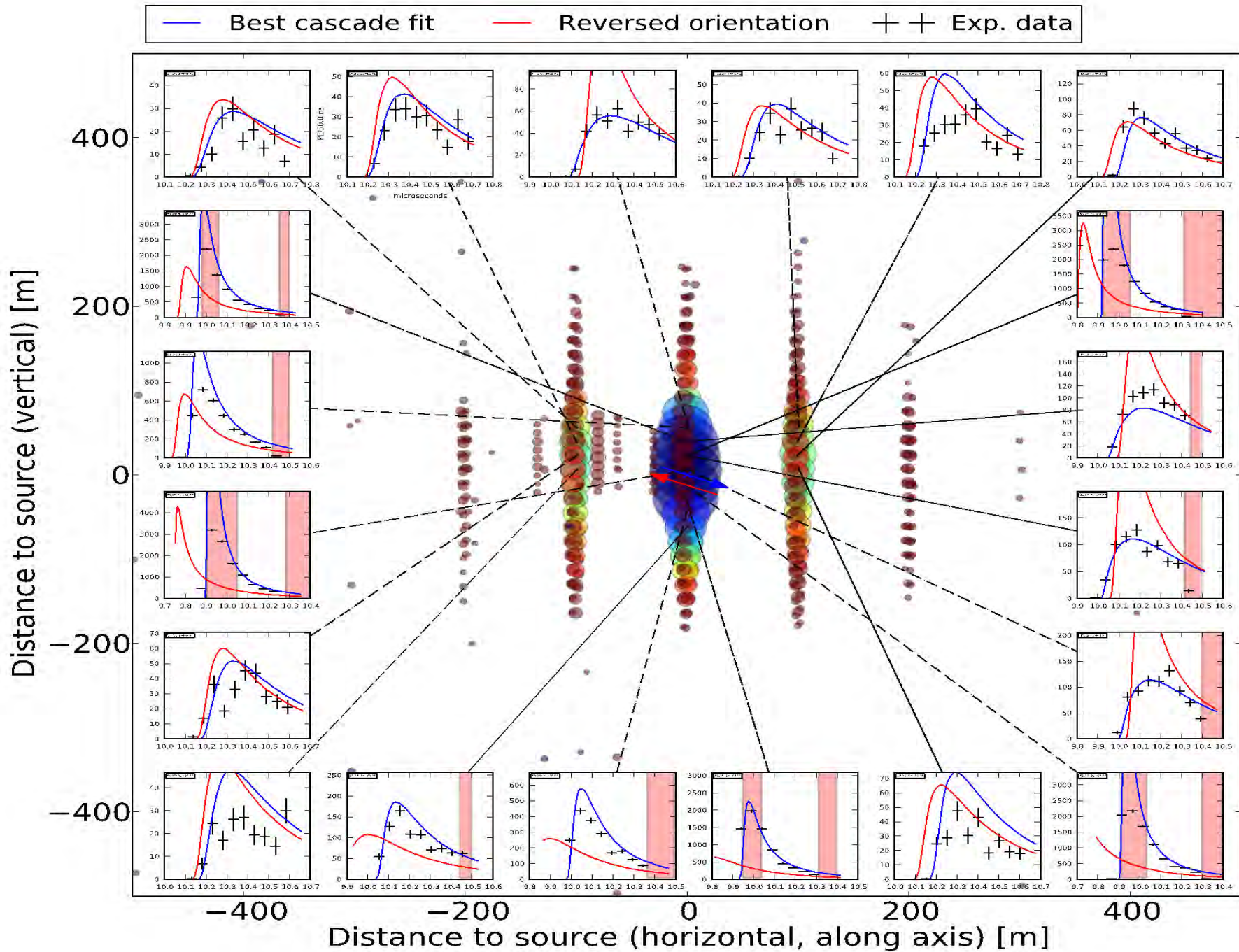

digital optical module 44 on string 20 only

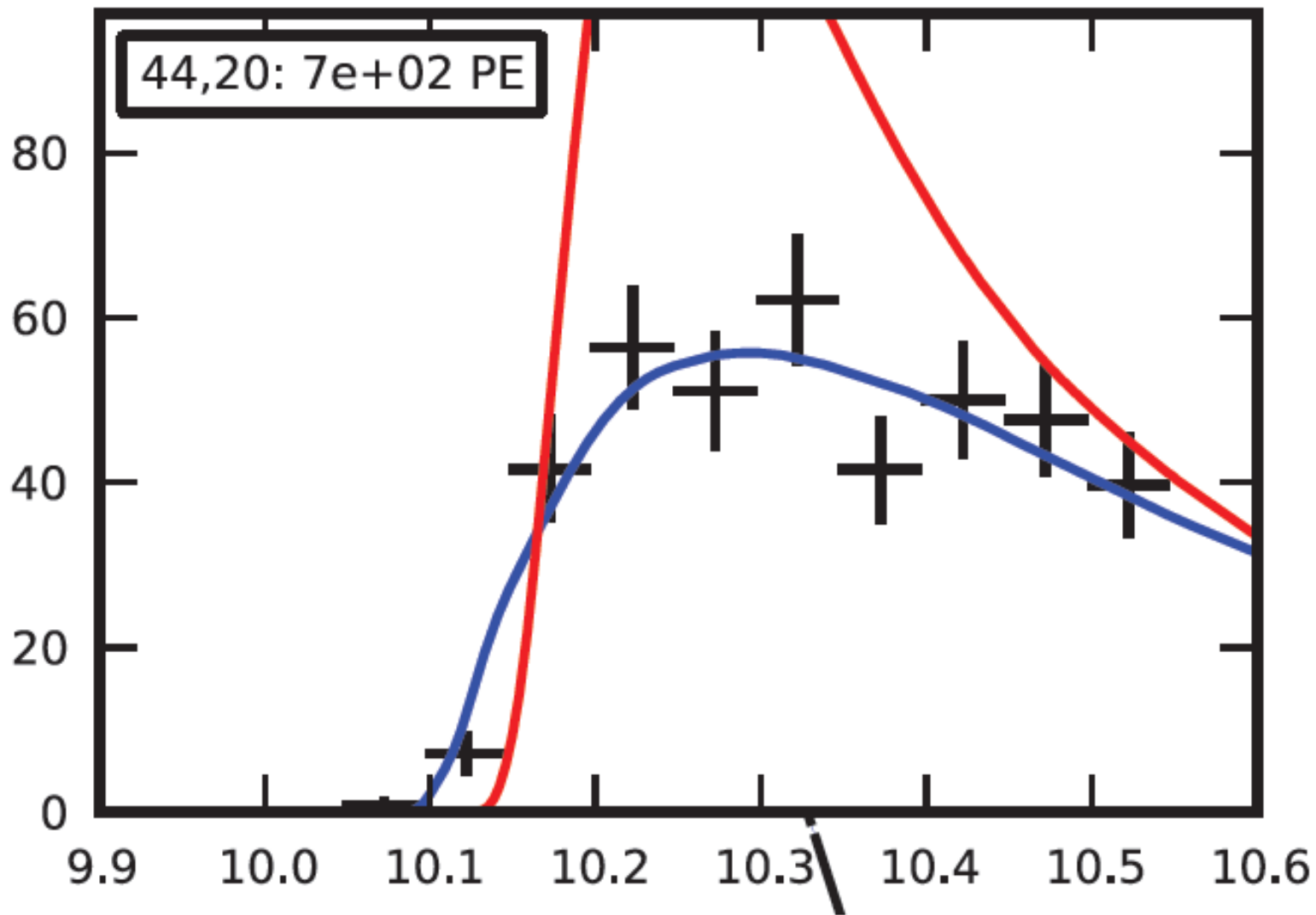

Blue: best-fit direction, red: reversed direction

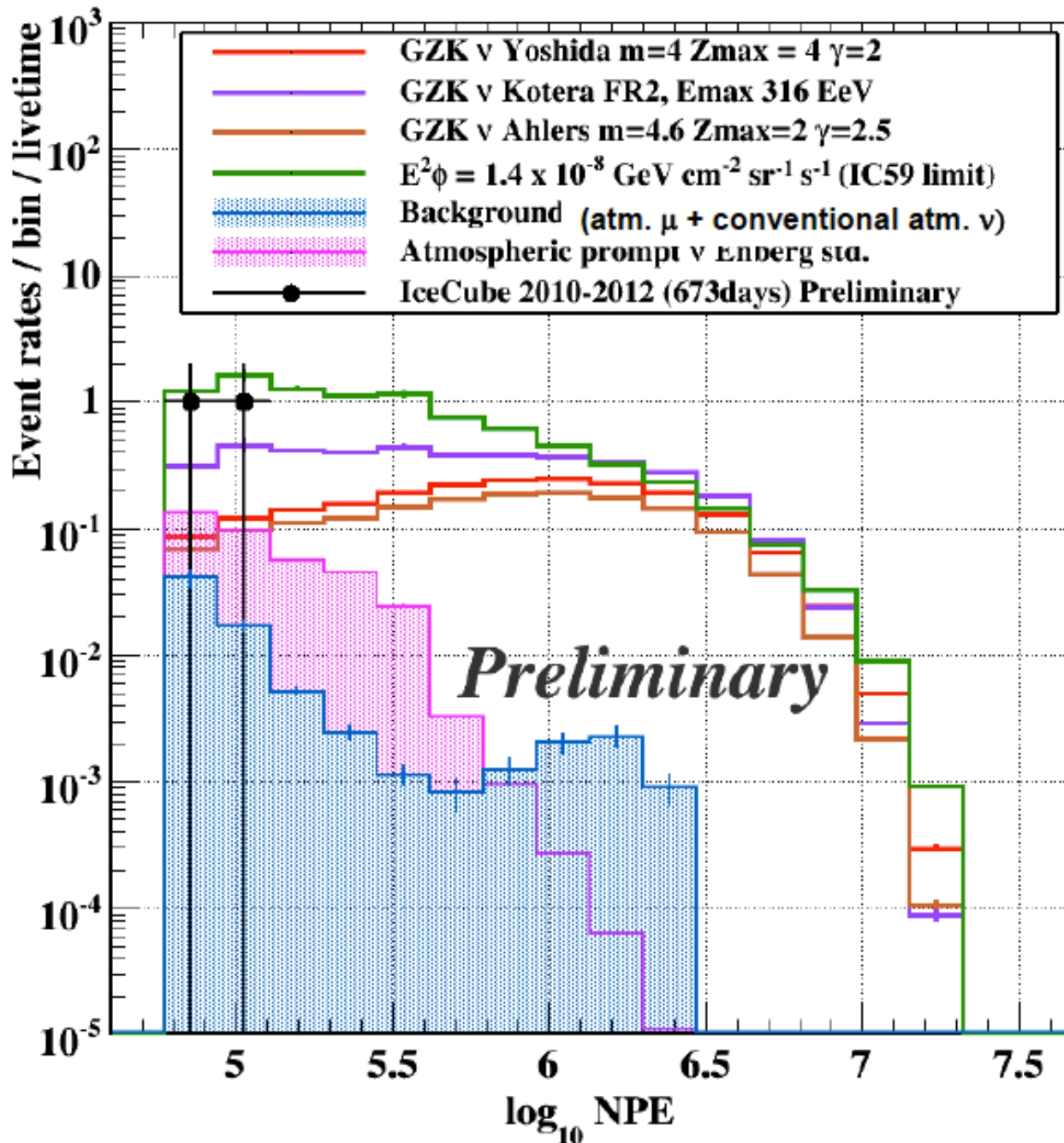

- energy
1,041 TeV
1,141 TeV
(15% resolution)
- not atmospheric:
probability of
no accompanying
muon is 10^{-3} per
event
- flux at present
level of diffuse
limit

- find more contained events (420 Mton)
- total calorimetry
- complete sky coverage
- flavor determined
- some will be muon neutrinos with good angular resolution



loss in statistics is compensated by event definition

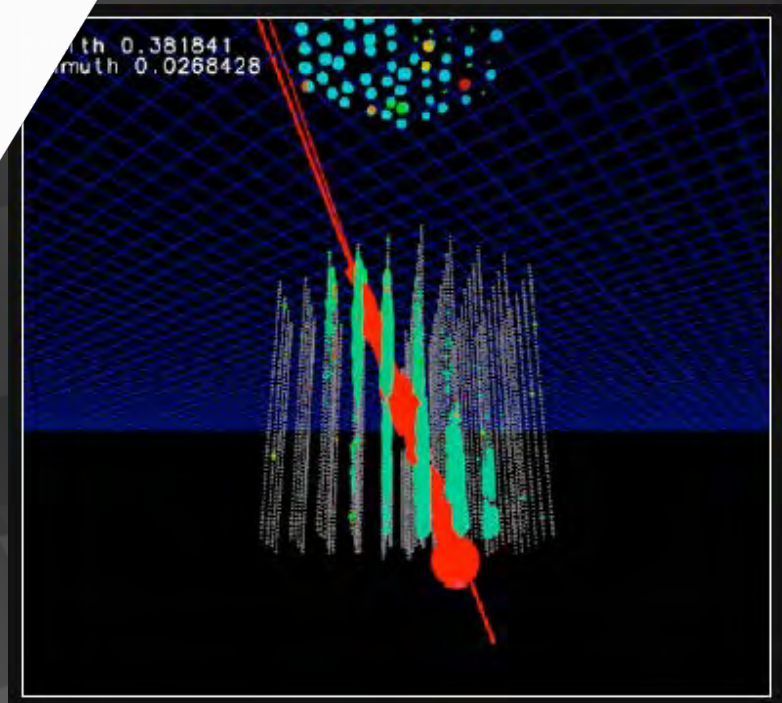
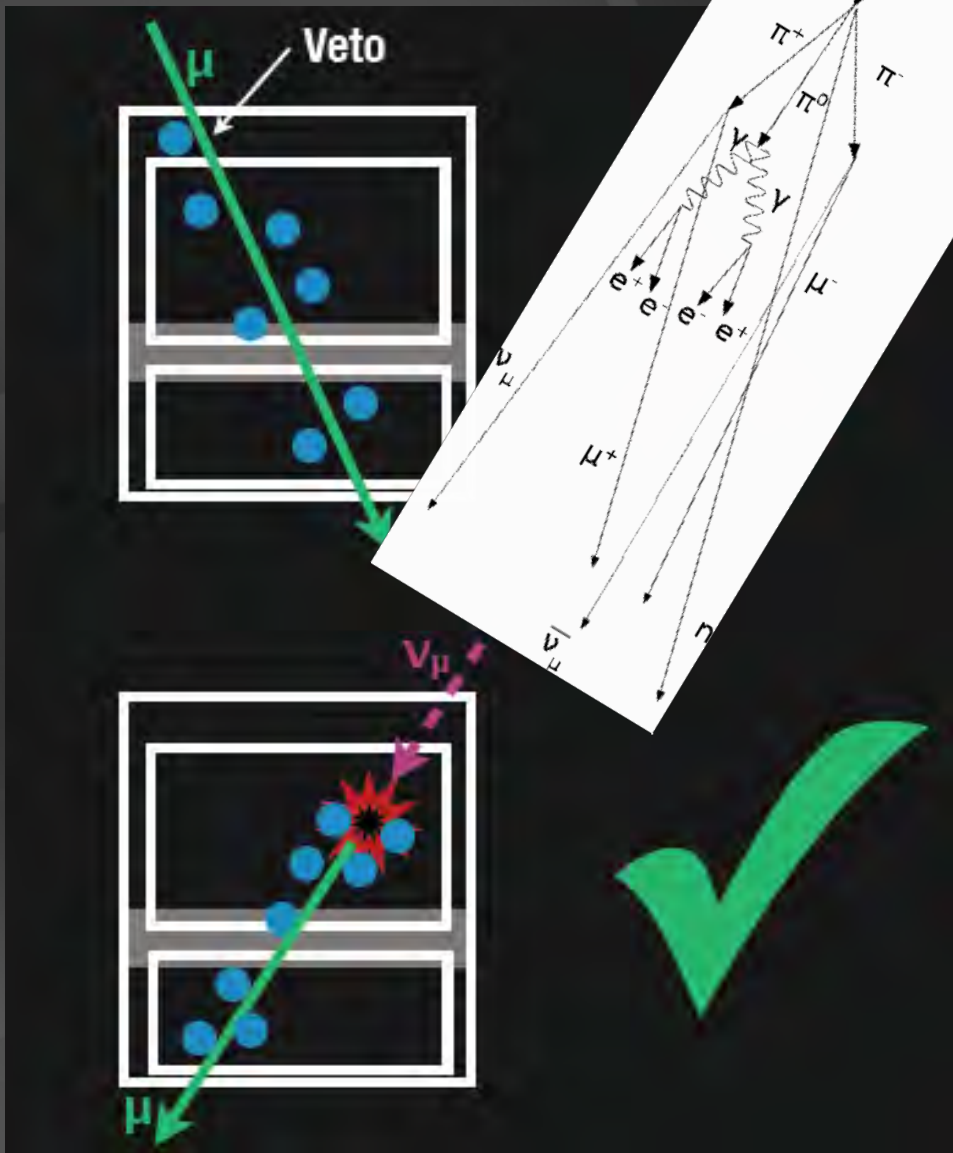

atmospheric neutrinos are accompanied by muons from the shower that produced them: none seen

(no signals in IceTop)

...and then there were 26 more...

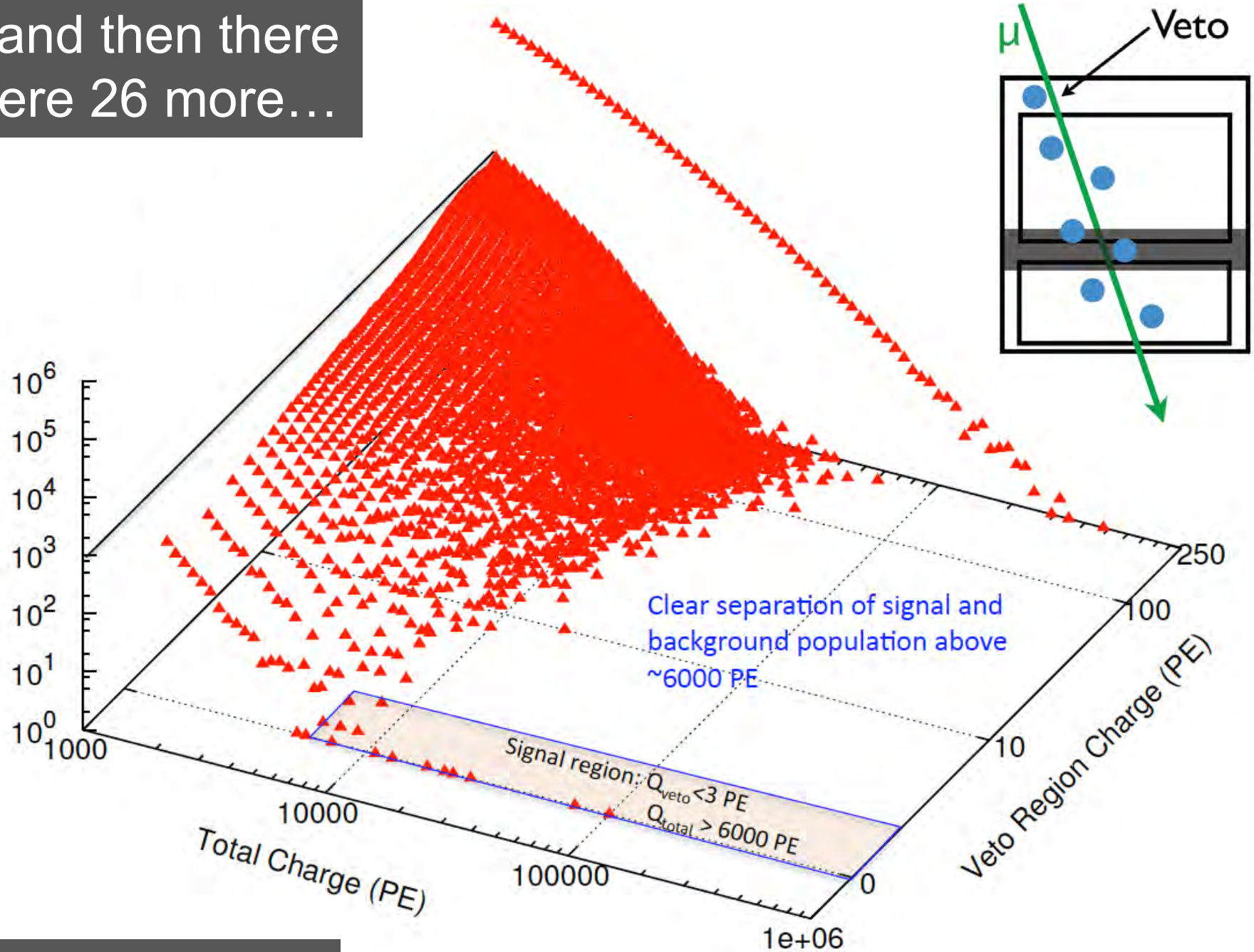

data: 86 strings one year

total charge collected by PMTs of events with interaction inside the detector

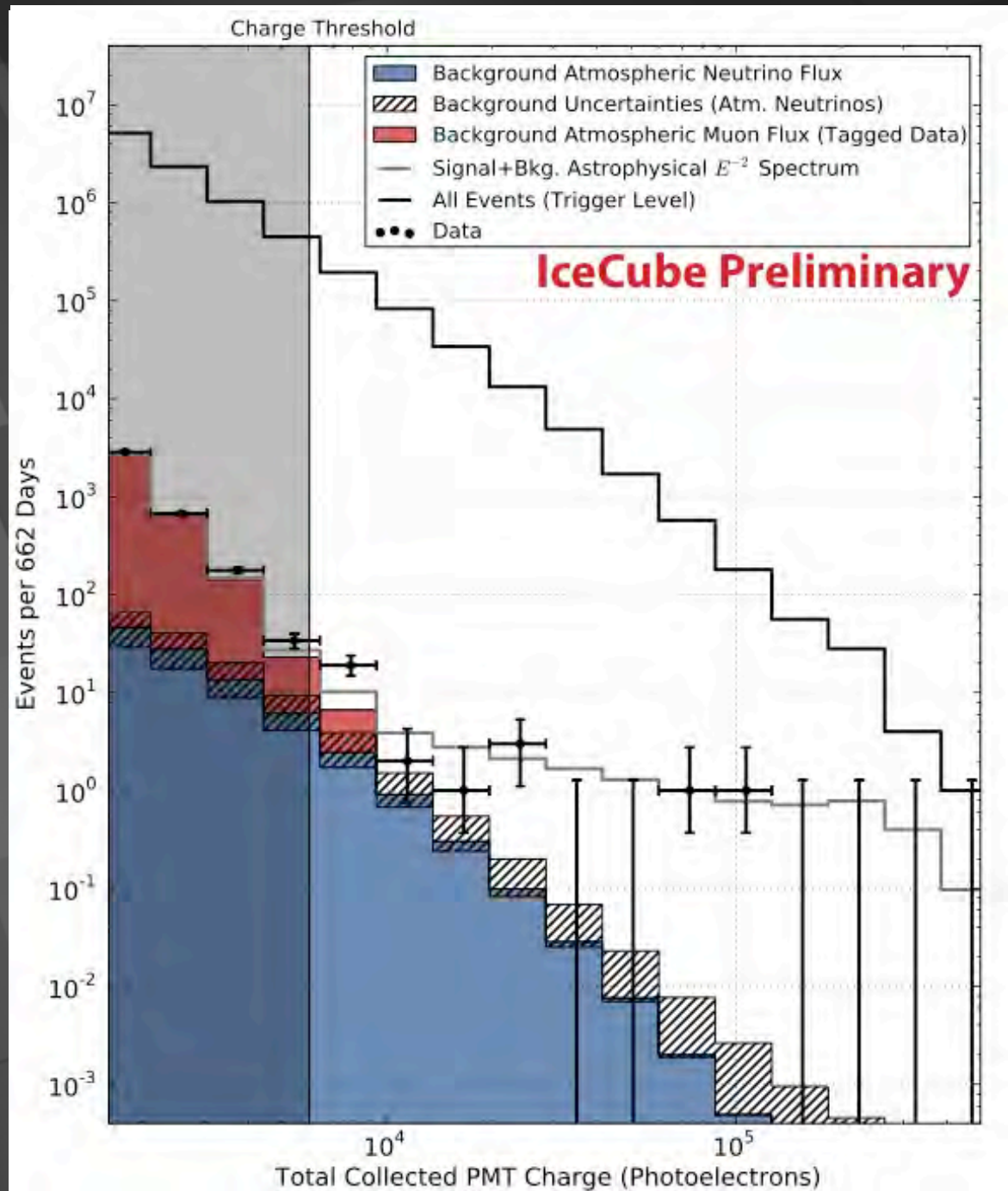

preliminary

> 100 TeV (50 em equivalent): 18 events

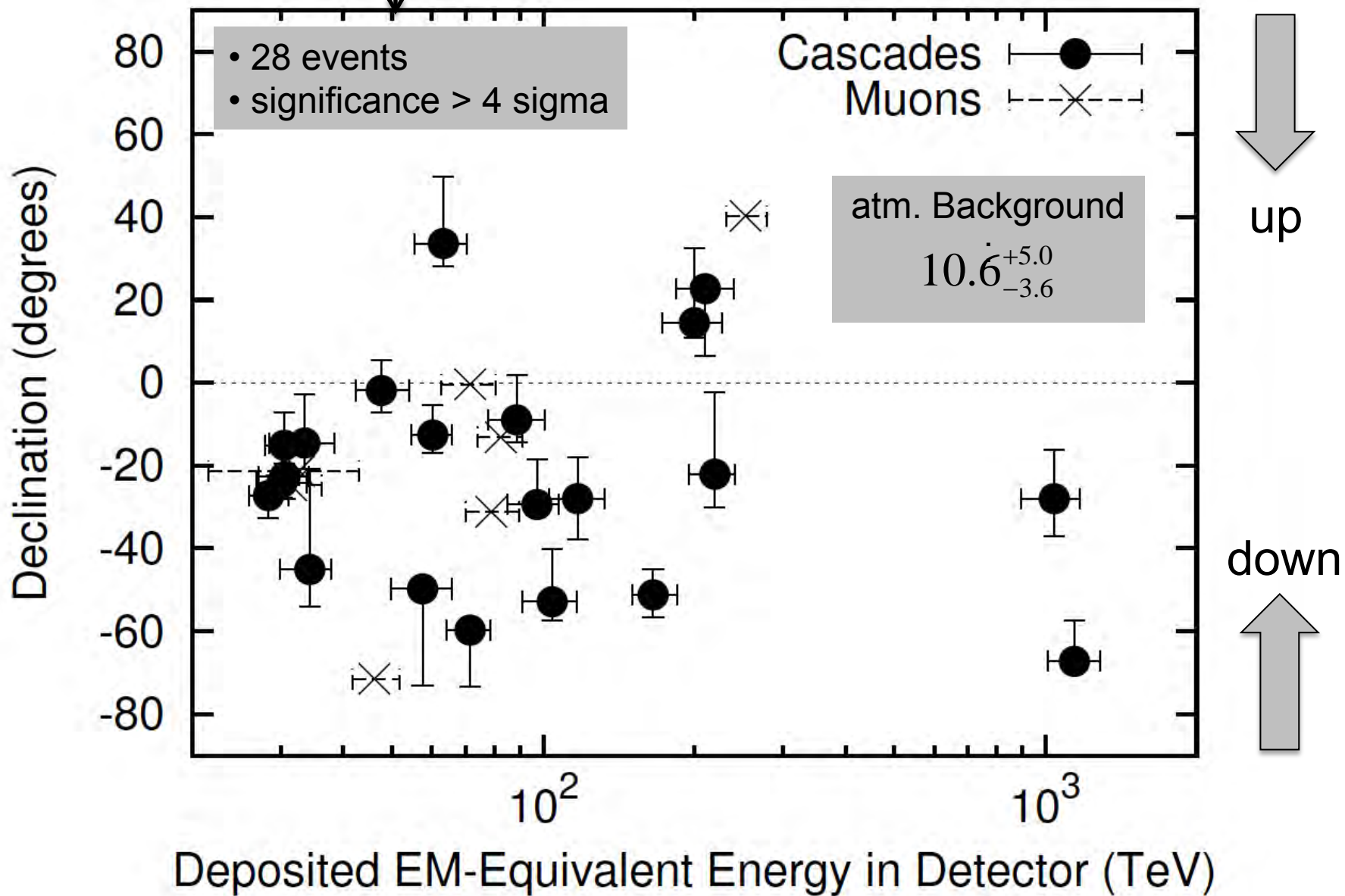

26 more: 19 showers and 7 muon tracks

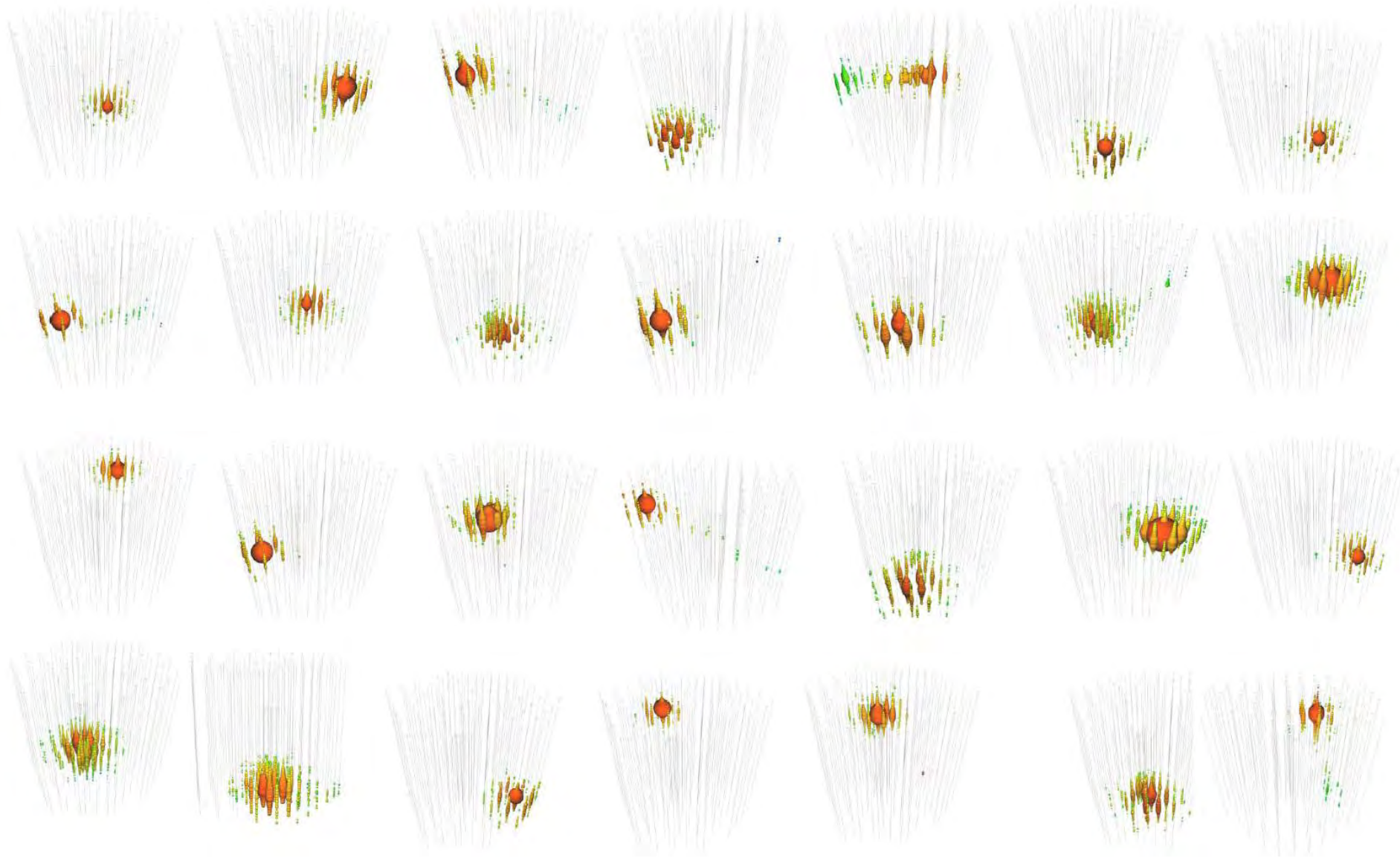

too few ν_μ ?

no, in an all flavor search ν_μ tracks are rare

$$\text{length of } \tau \text{ track} = 50\text{m} \times \frac{E_\nu}{\text{PeV}}$$

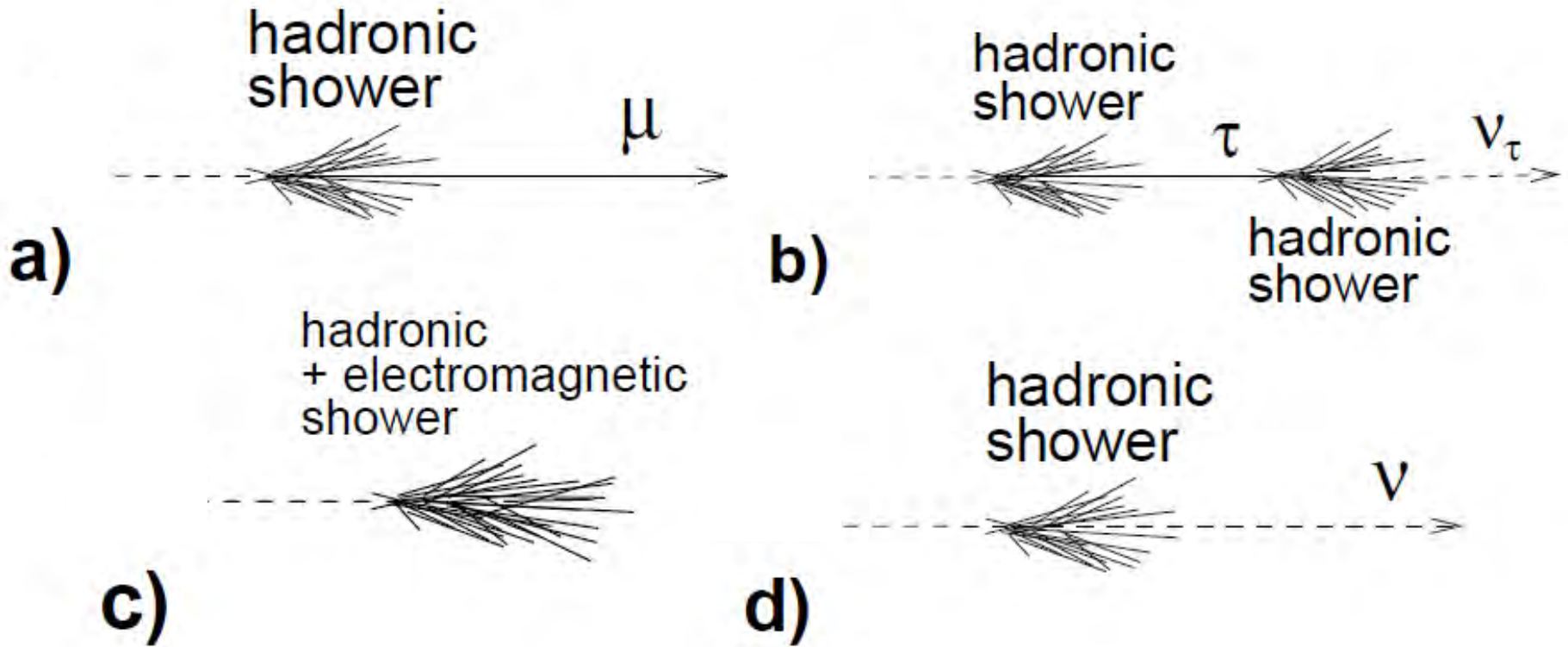

a muon track is relatively rare

mostly from South (not through the Earth) ✓

Conventional Background

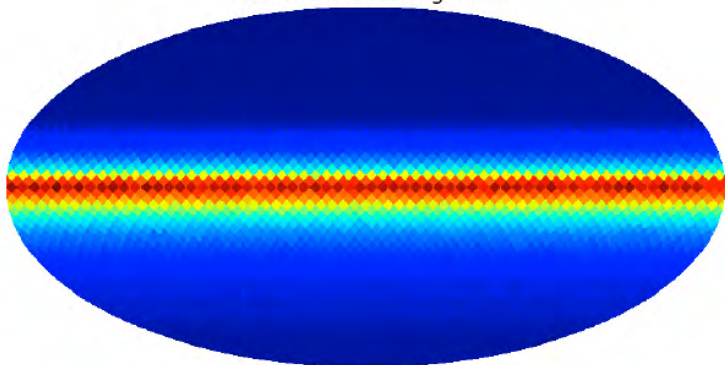

EMinus2 Iso Background $3 \times 10^8 \text{ GeV cm}^{-2} \text{ s}^{-1} \text{ str}^{-1}$ (All Flavour)

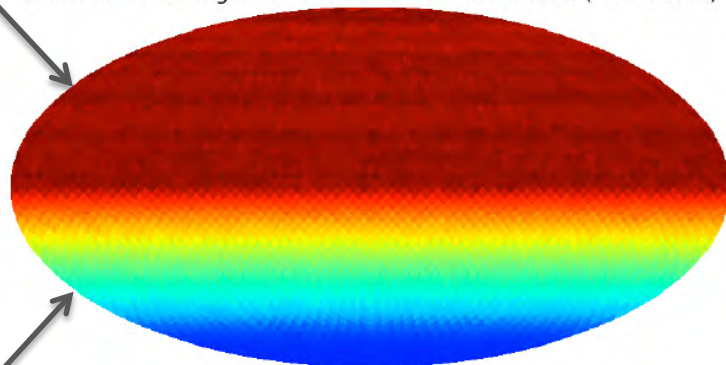

PeV ν 's absorbed

Prompt Background

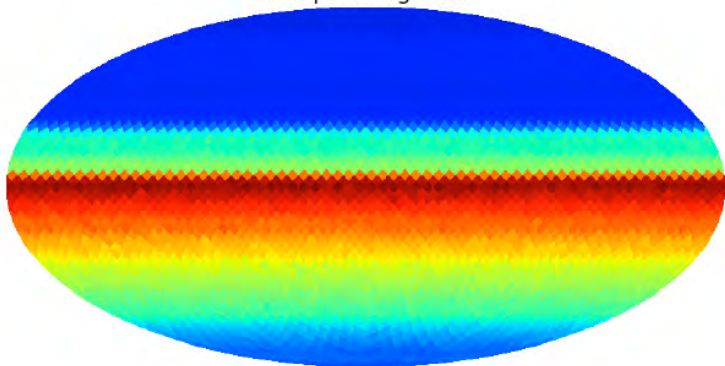

background

Point Source 15deg ($\pi/4, 0$) $1.9 \times 10^9 \text{ GeV cm}^{-2} \text{ s}^{-1}$ (All Flavour)

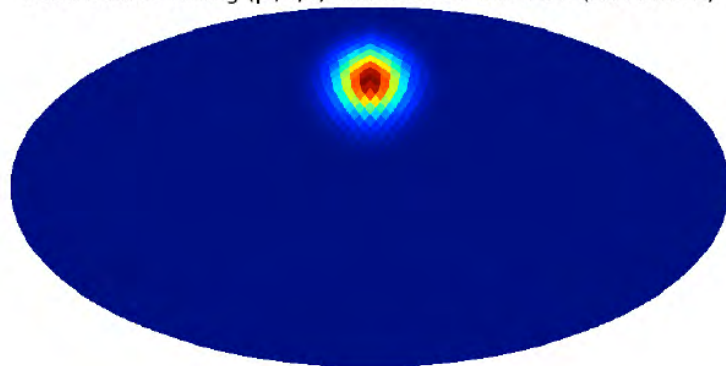

signal

too many from the northern hemisphere?
no, events have properties of a cosmic flux

atmospheric background:

- mostly from North (through the Earth, insufficient target to produce neutrinos from the South)
- mostly muons (muon neutrinos and cosmic ray muons from the South)

cosmic flux:

- mostly from the South (PeV neutrinos absorbed by the Earth)
- mostly showers (1:1:1 flavor composition and only CC muon neutrinos produce a track)

not neutrinos from production and prompt decay of charmed particles in the atmosphere

- IceCube data do not fit the energy dependence required by a charm signal.
- same for the zenith angle dependence.
- rate required to explain the data exceeds our own experimental limit by more than a factor of 2.
- level of charm background allowed by the data (actually, no evidence yet) is consistent with expectations.
- no evidence for the air shower that would have produced the charmed particle (no muons!).

some interesting events

IceCube Preliminary

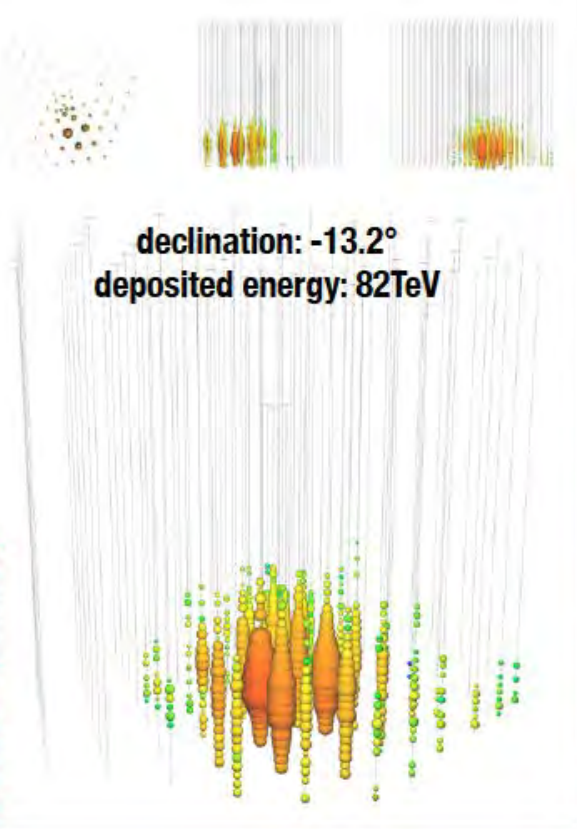

IceCube Preliminary

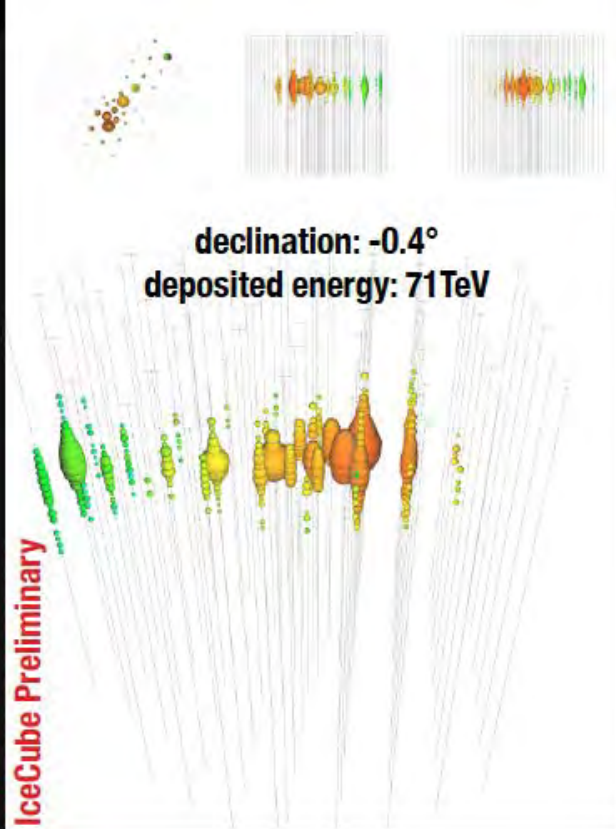

IceCube Preliminary

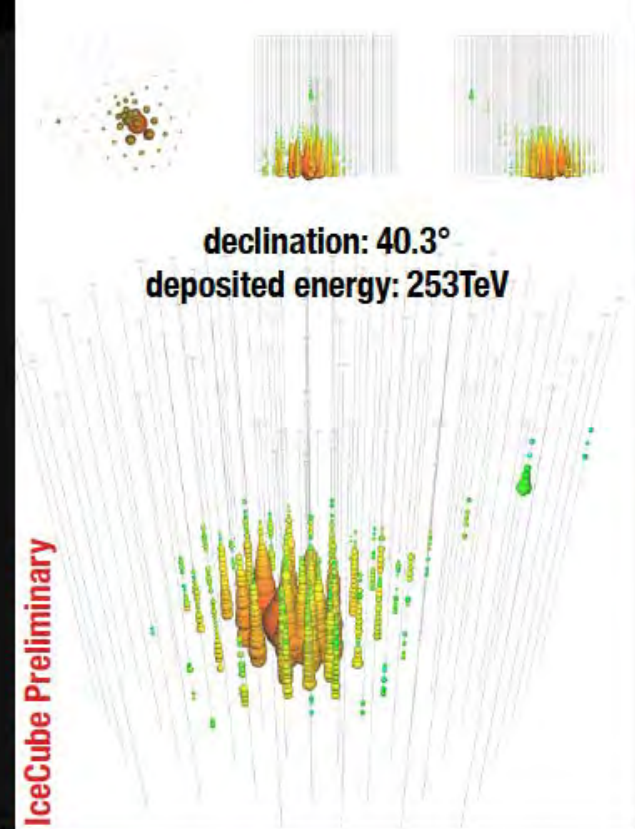

Thu, 14 Jul 2011 02:42:41 UTC
t = 9700 ns

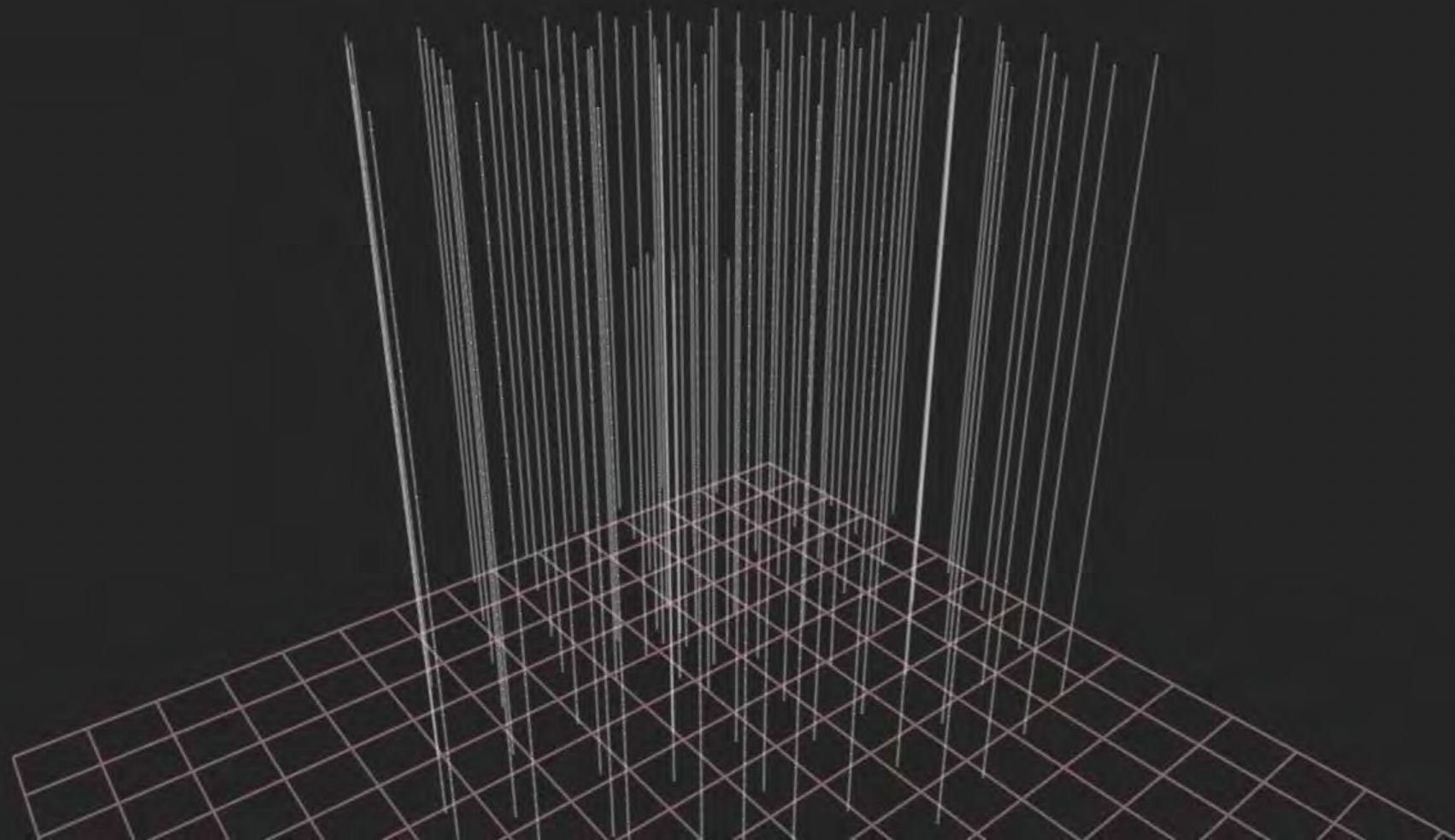

atmospheric muon (blue) + neutrino (red) background
+ astrophysical $E^2\Phi(E) = (3.6 \pm 1.2) \cdot 10^{-8} \text{ GeVcm}^{-2}\text{s}^{-1}\text{sr}^{-1}$

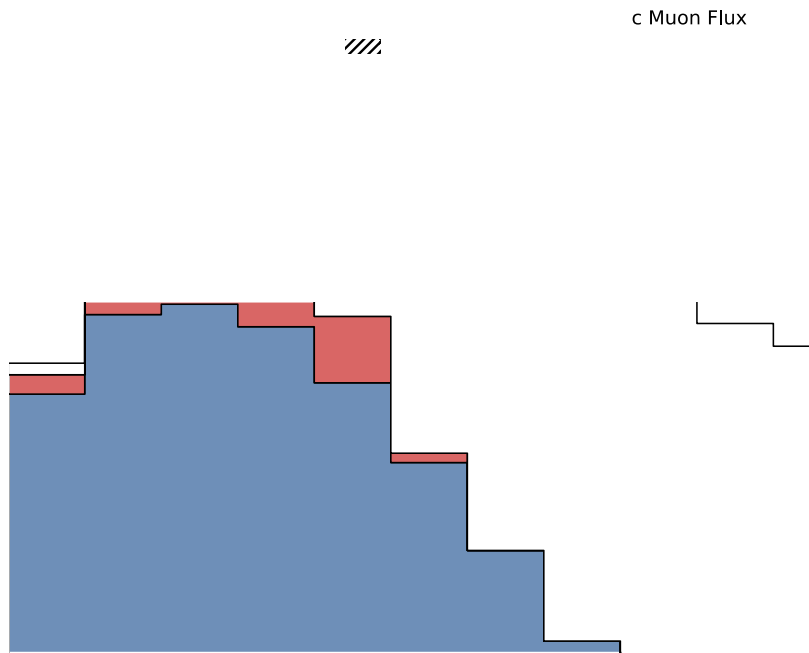

energy deposited in the detector

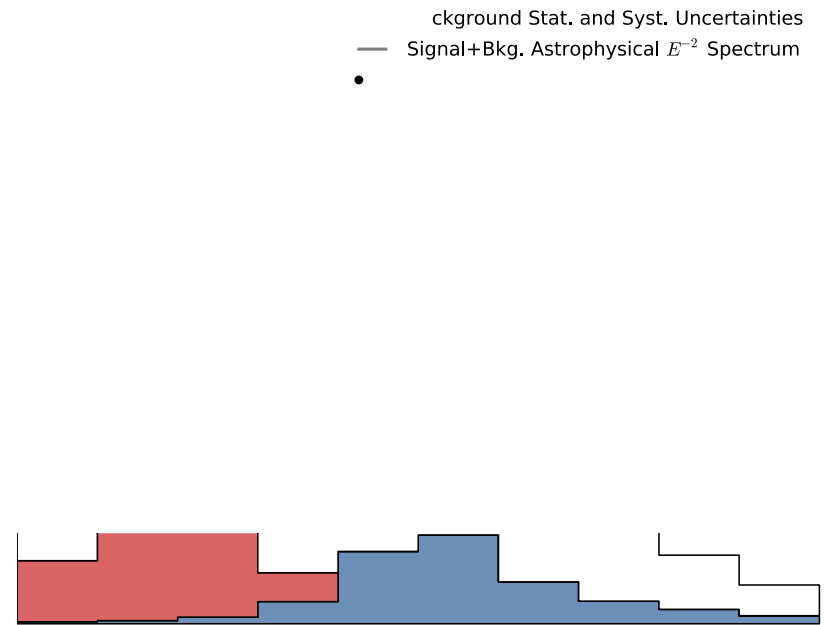

zenith angle

Most likely event direction
x track-like events
+ shower-like events

PRELIMINARY

**shower events
p-value = 8%**

**all events
p-value = 80%**

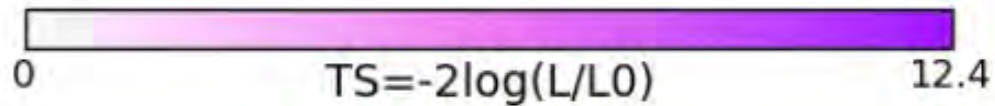
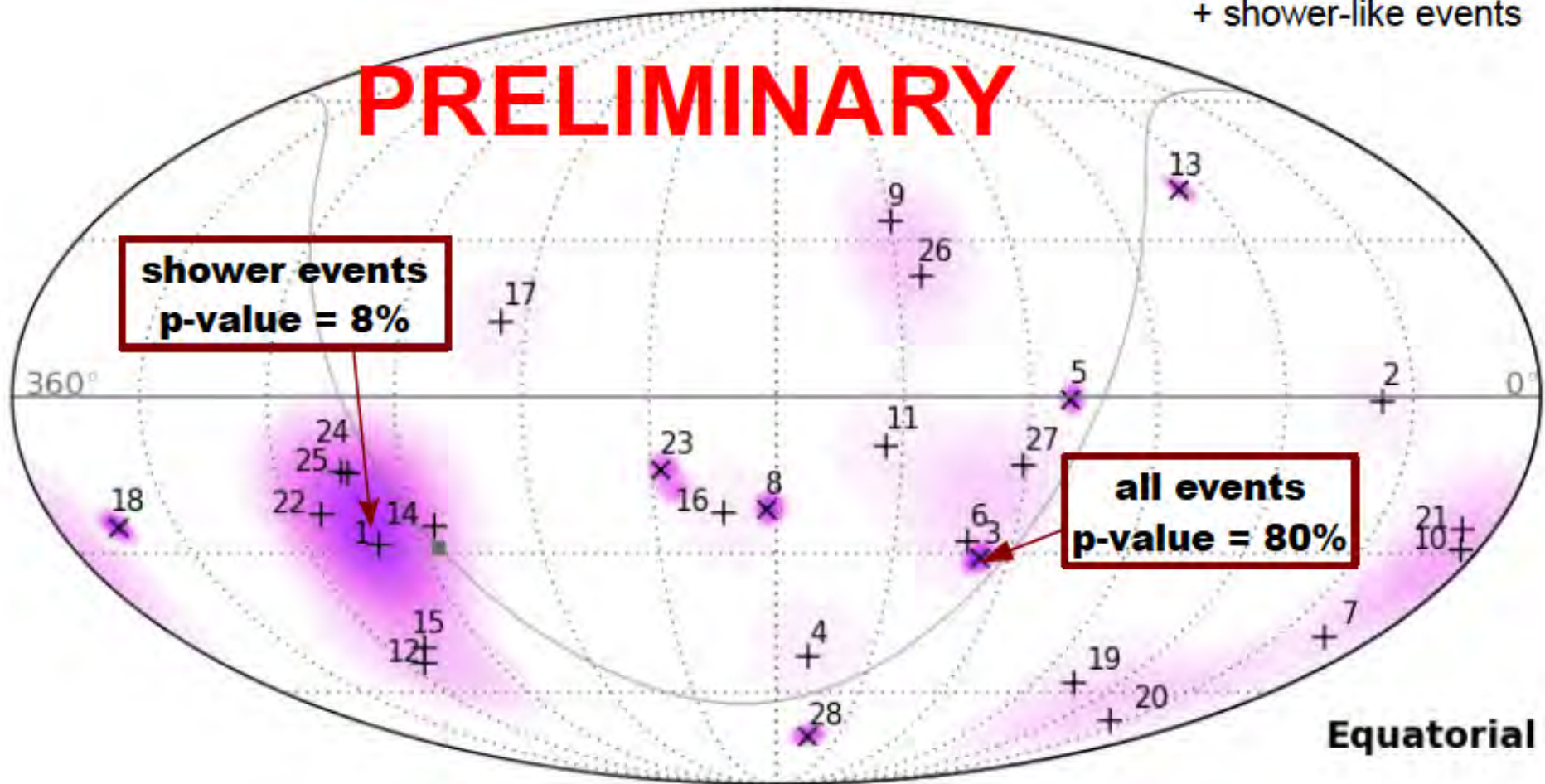

Galactic coordinates

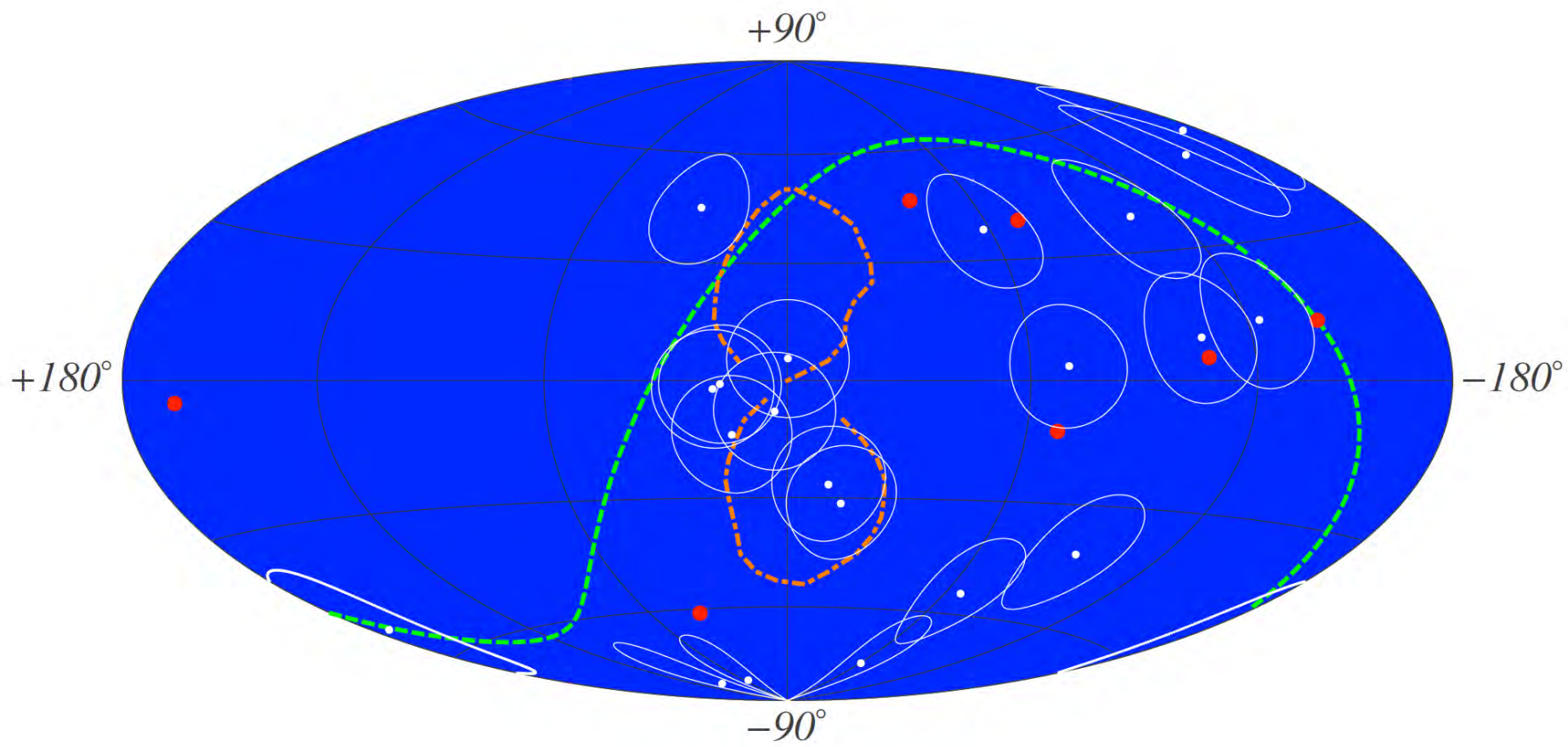

Galactic coordinates arXiv 1309.4077

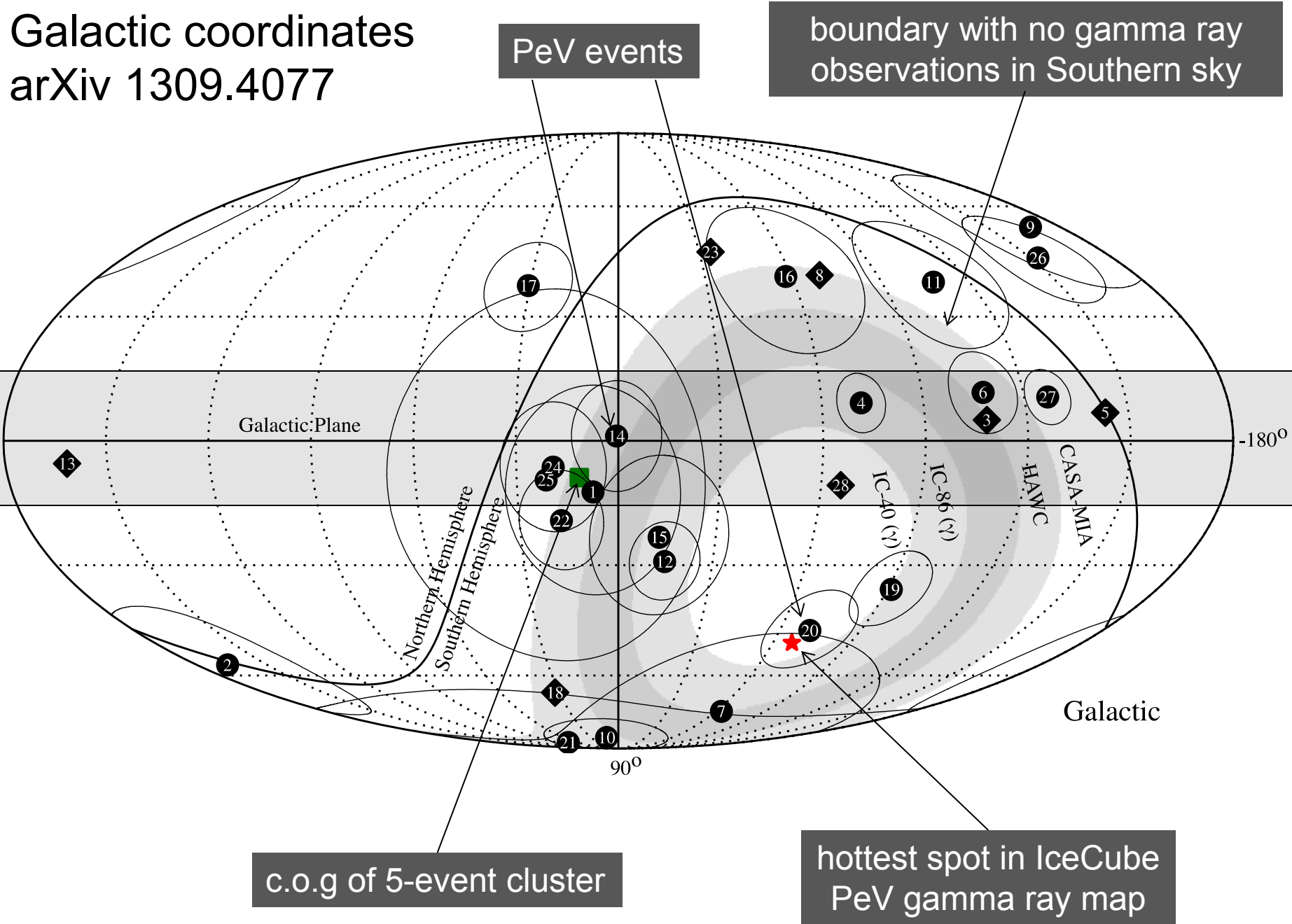

the energy range of cosmic accelerators producing PeV neutrinos

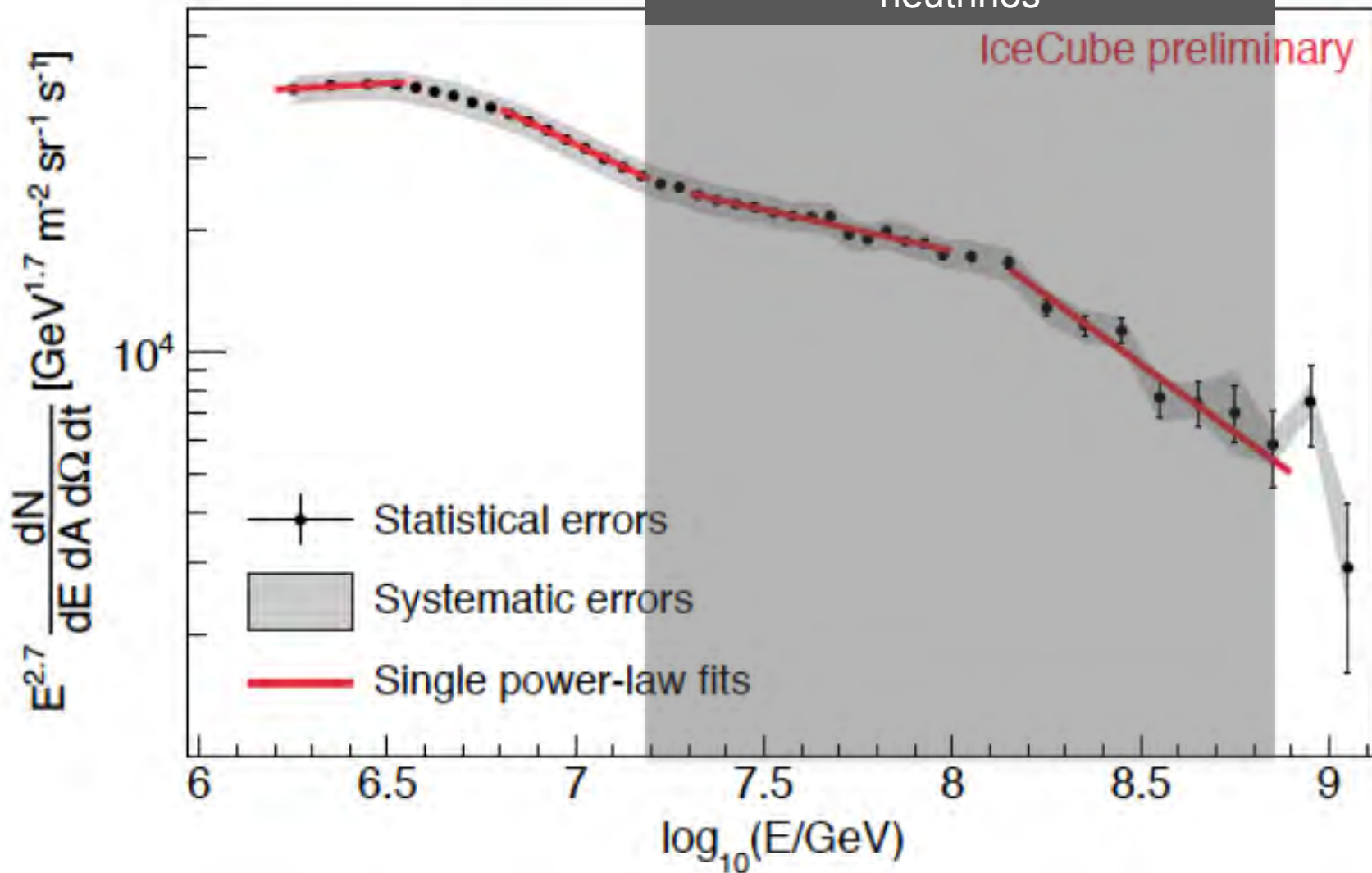

Galactic or extragalactic?



conclusions

- first evidence for cosmic neutrinos
- origin not revealed yet, but...
- one more year of data ready for unblinding, more being taken
- better and different (more ν_{μ}) analyses soon

10% of data taken during year 2 of IceCube unblinded

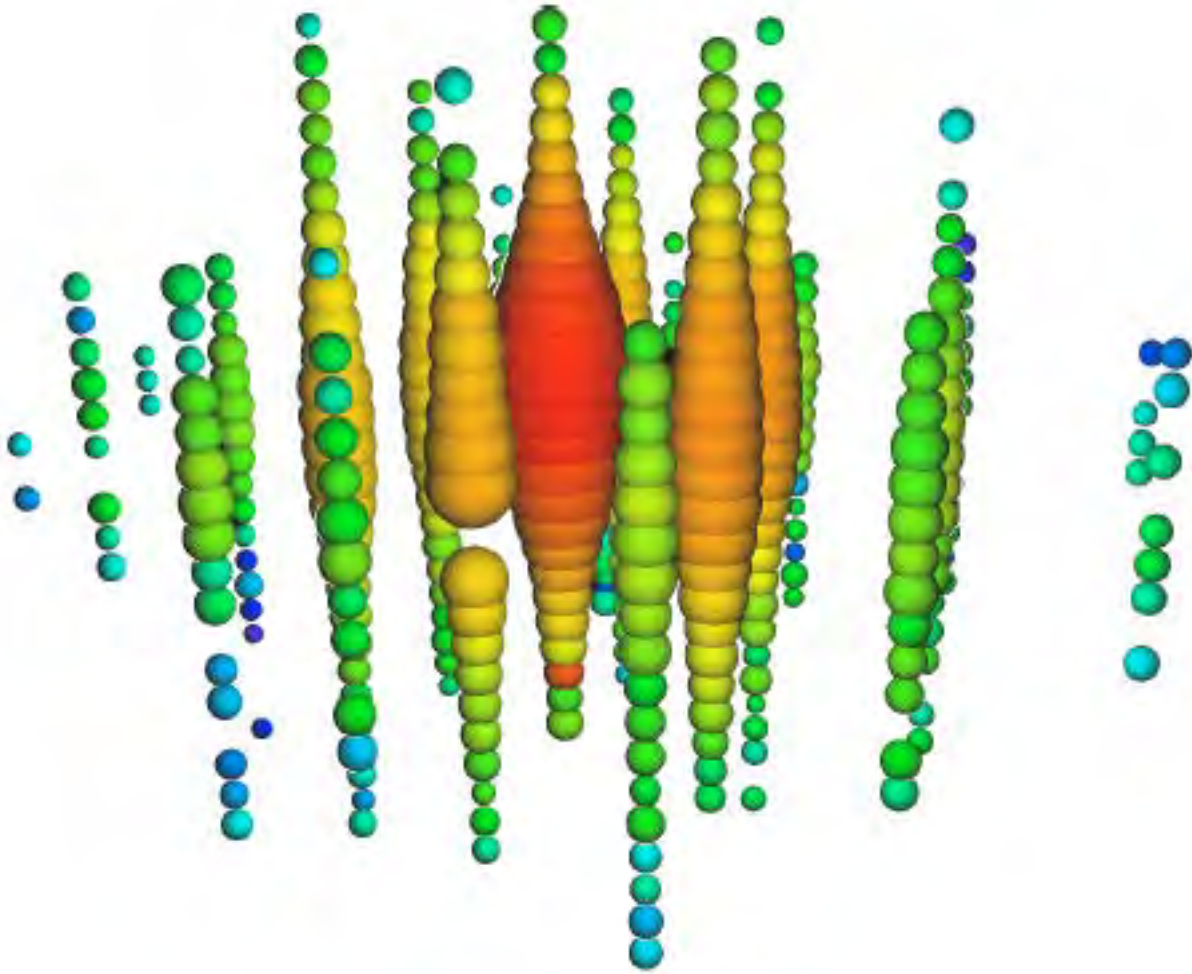

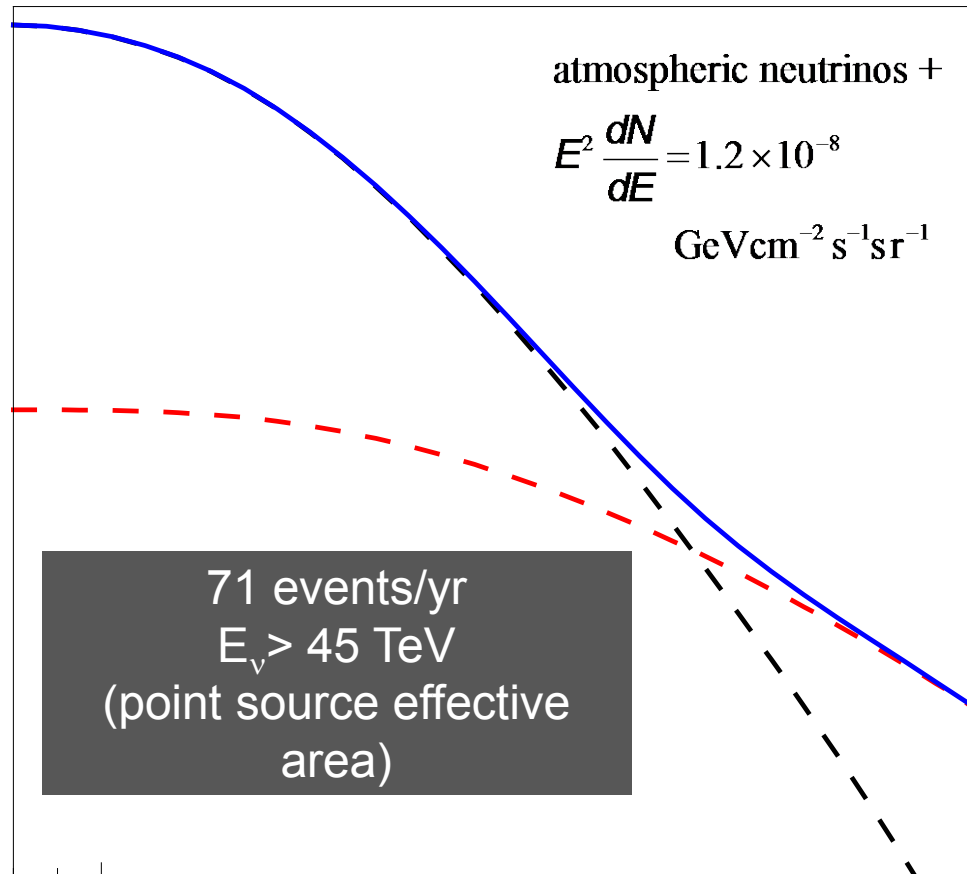

energy of the muon inside the detector (GeV)

increase in threshold not important
(in the region where atmospheric background dominates)

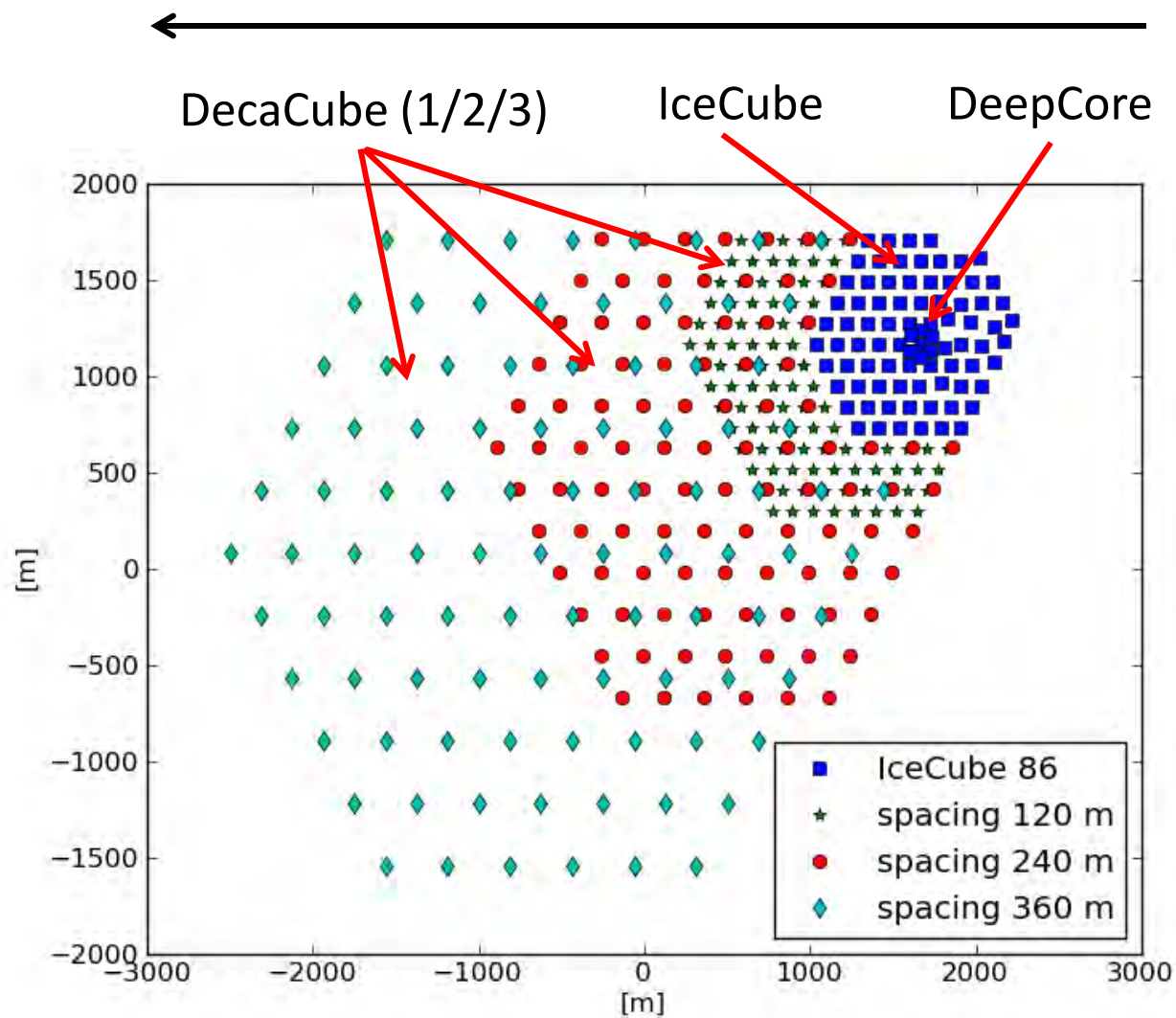

Spacing 1 (120m):
IceCube (1 km³)
+ 98 strings (1,3 km³)
= 2,3 km³

Spacing 2 (240m):
IceCube (1 km³)
+ 99 strings (5,3 km³)
= 6,3 km³

Spacing 3 (360m):
IceCube (1 km³)
+ 95 strings (11,6 km³)
= 12,6 km³



The IceCube Collaboration

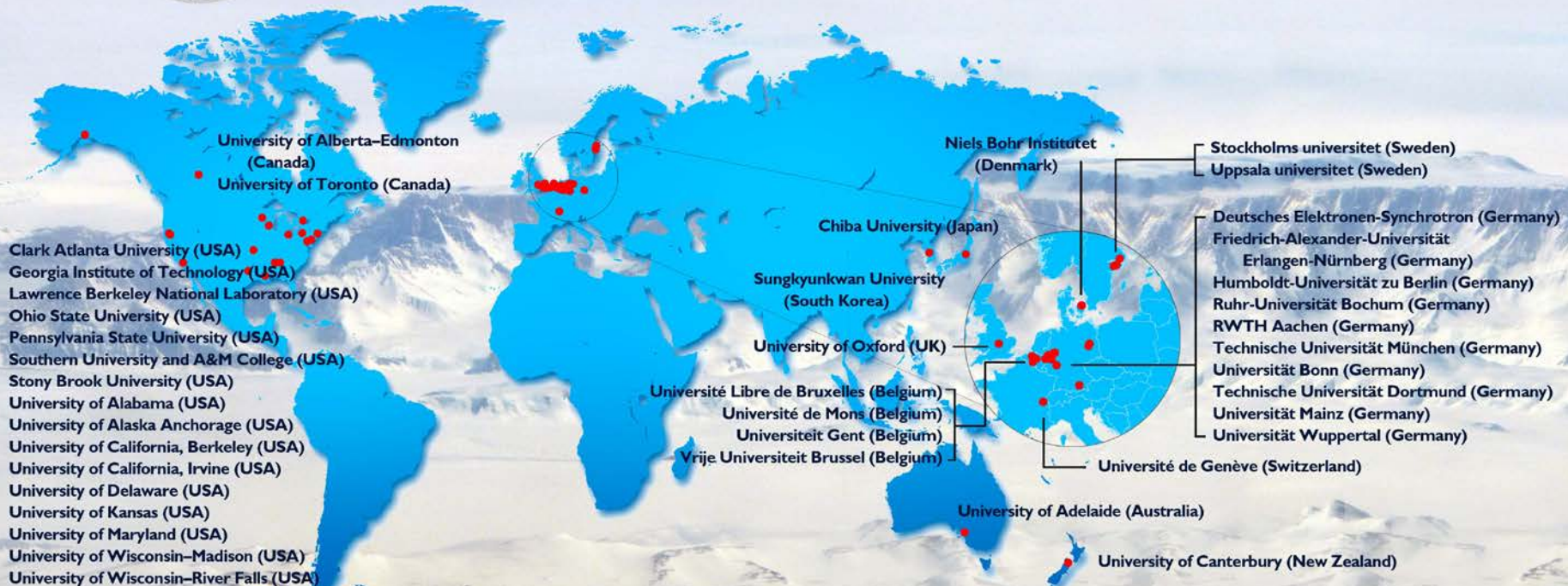

Funding Agencies

Fonds de la Recherche Scientifique (FRS-FNRS)
Fonds Wetenschappelijk Onderzoek-Vlaanderen (FWO-Vlaanderen)
Federal Ministry of Education & Research (BMBF)
German Research Foundation (DFG)

Deutsches Elektronen-Synchrotron (DESY)
Japan Society for the Promotion of Science (JSPS)
Knut and Alice Wallenberg Foundation
Swedish Polar Research Secretariat
The Swedish Research Council (VR)

University of Wisconsin Alumni Research Foundation (WARF)
US National Science Foundation (NSF)