

ATLAS Commissioning with cosmic rays and first LHC beam

IFIC Seminar
17/10/2008

Luca Fiorini¹

1: Institut de Física d' Altes Energies (Barcelona)





Outline

- Introduction
- Detector Status
 - Inner Detector
 - Calorimeters
 - Muon Systems
 - Trigger System
- Commissioning
 - Cosmics data
 - First Beam data
- Detector Performance
 - Cosmics Analysis
 - Single Beam Analysis
- Conclusions

ATLAS Collaboration
37 Countries
169 Institutions
2500 Scientific Authors total
(1800 with a PhD)

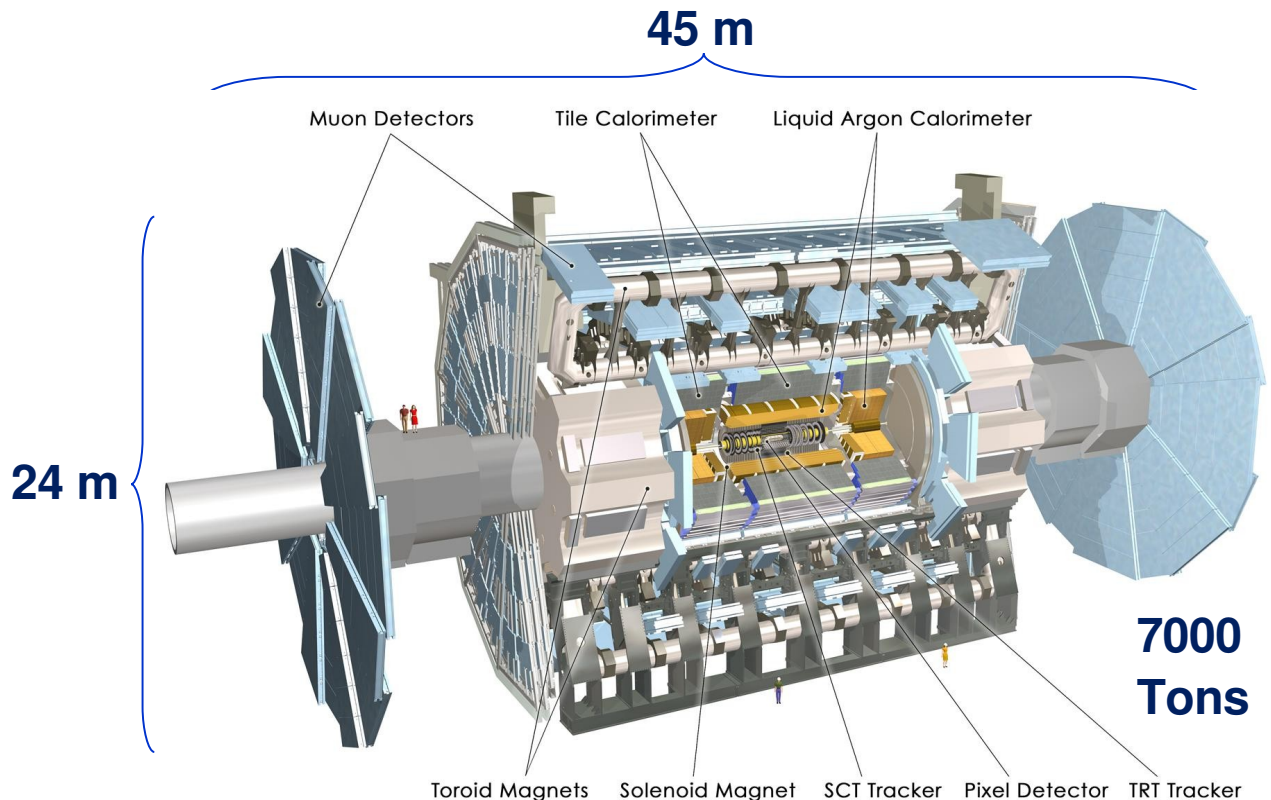



LHC Collider

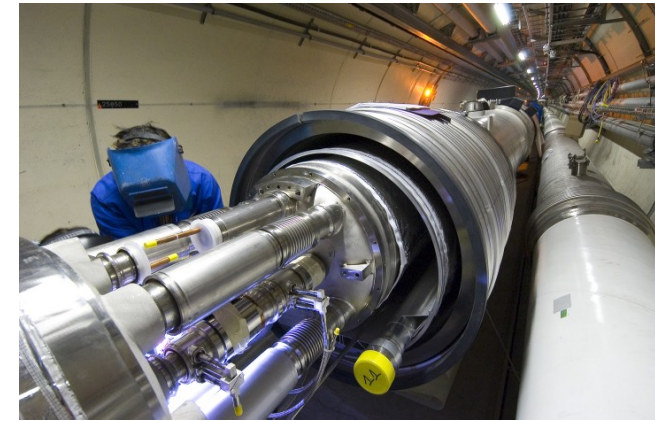

LHC Design Performance

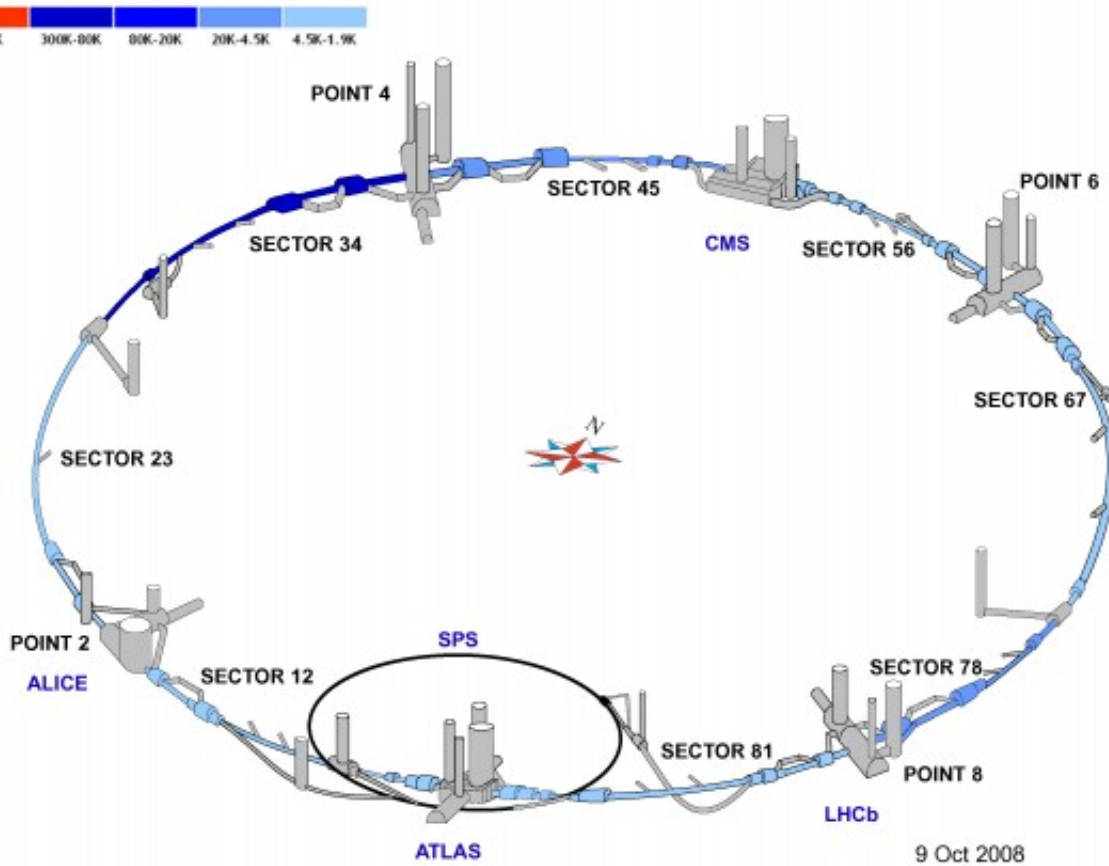

	Injection	Collisions
Proton energy (GeV)	450	7000
Luminosity (cm ⁻² s ⁻¹)	-	10 ³⁴
Particles per bunch	1.15 · 10 ¹¹	
Number of bunches	2808	
Circulating current (A)	0.58	
Stored Energy (MJ)	23.3	362
RMS bunch length (cm)	11.24	7.55
RMS beam size (μm)	375.2	16.7



Detector closure



- The underground cavern was finished in June 2003
- Detector was closed in April 2008
- LHC beam pipe completely sealed in June 2008



Aerial view of Point1

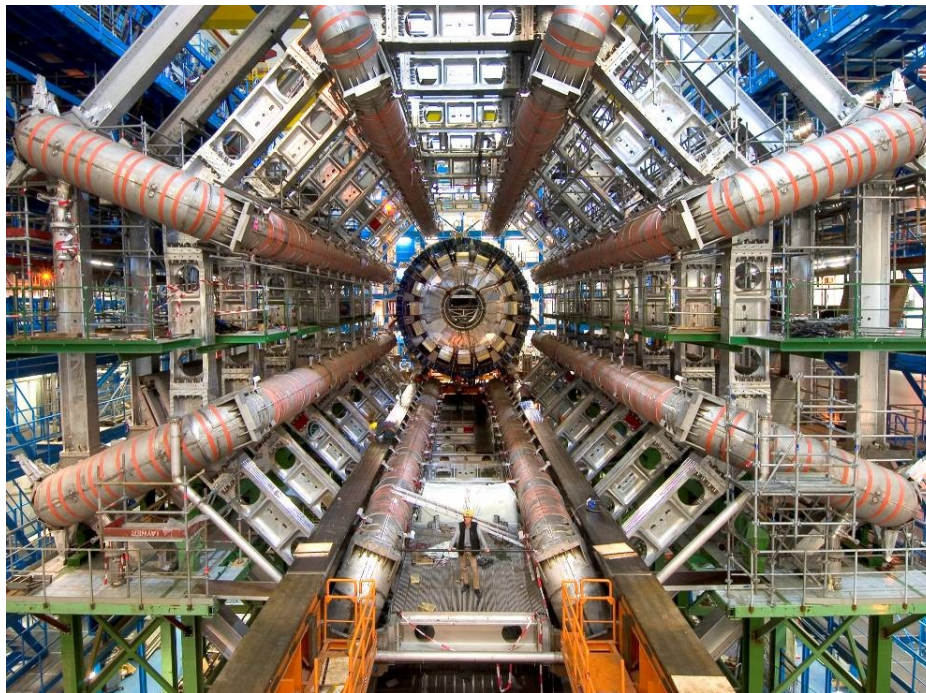

Calorimeter insertion into the barrel toroid magnets

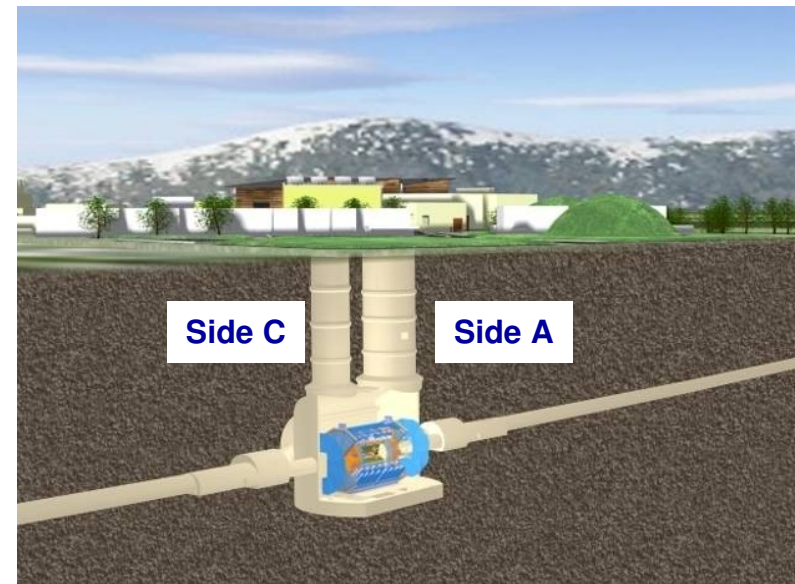

Atlas cavern below Point1



Inner Detector Status

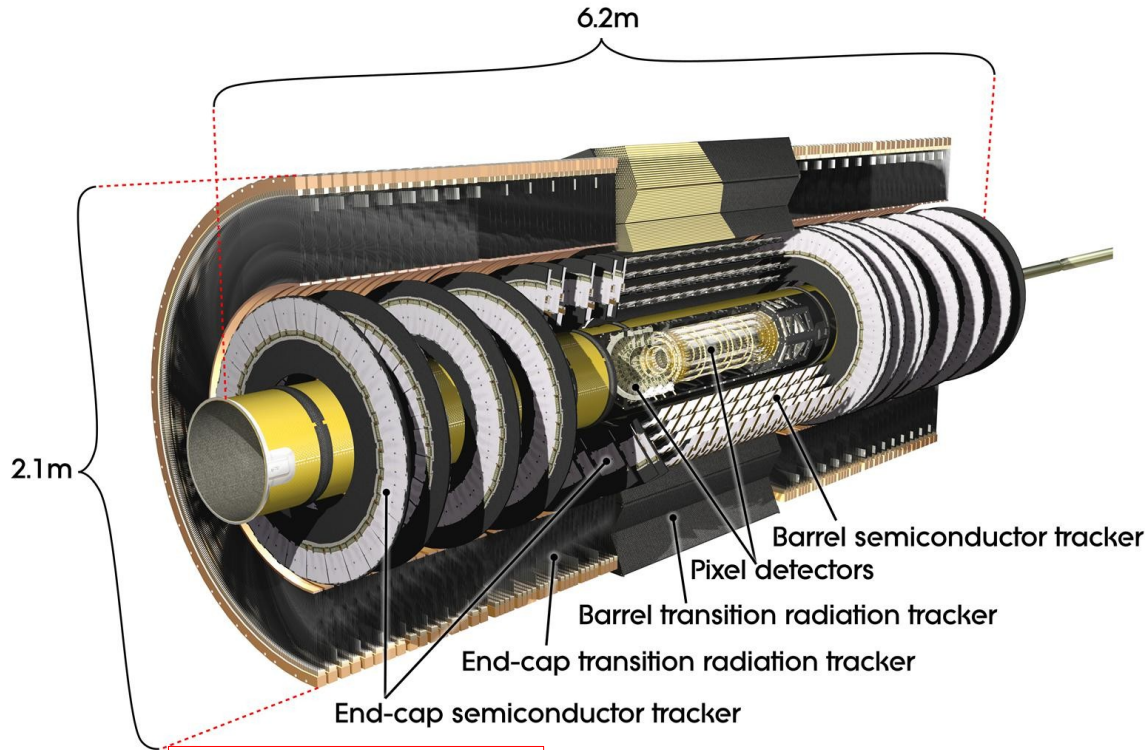

Pixels
($0.8 \cdot 10^8$ channels)

Si Strips Tracker (SCT)
($6 \cdot 10^6$ channels)

Transition Radiation Tracker (TRT)
($4 \cdot 10^5$ channels) with e/π separation

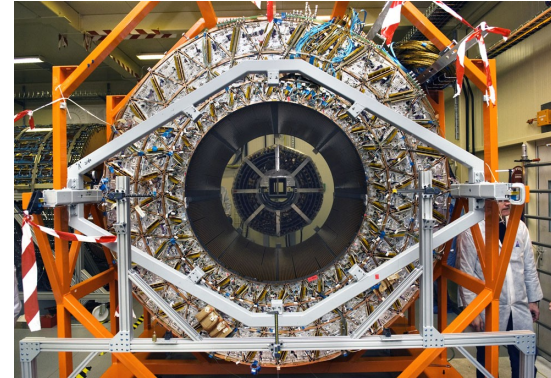

370000 TRT drift straws, 40 ns max drift time

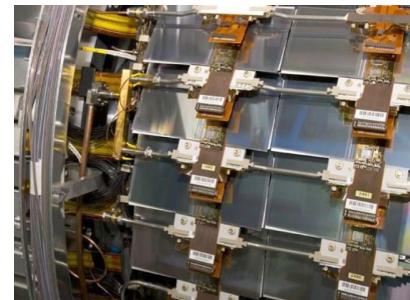

4088 SCT modules, 80 μm micro-strips

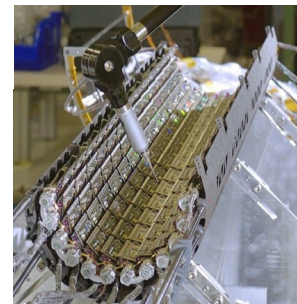

1744 Pixel modules, pixels $50 \times 400 \mu\text{m}^2$



Inner Detector Tracking

ATLAS ID Tracking Design Performance

2 Tesla solenoid $\sigma/p_T \sim 0.05\%$ $p_T(\text{GeV}) \oplus 1\%$

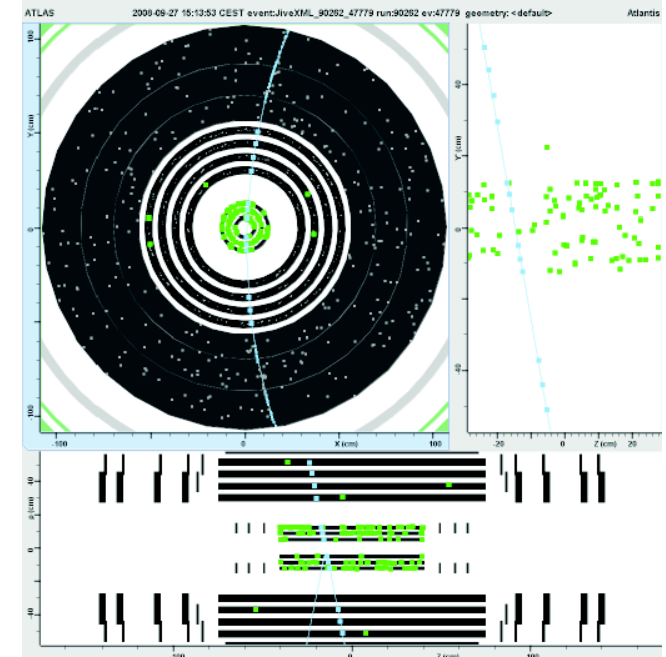
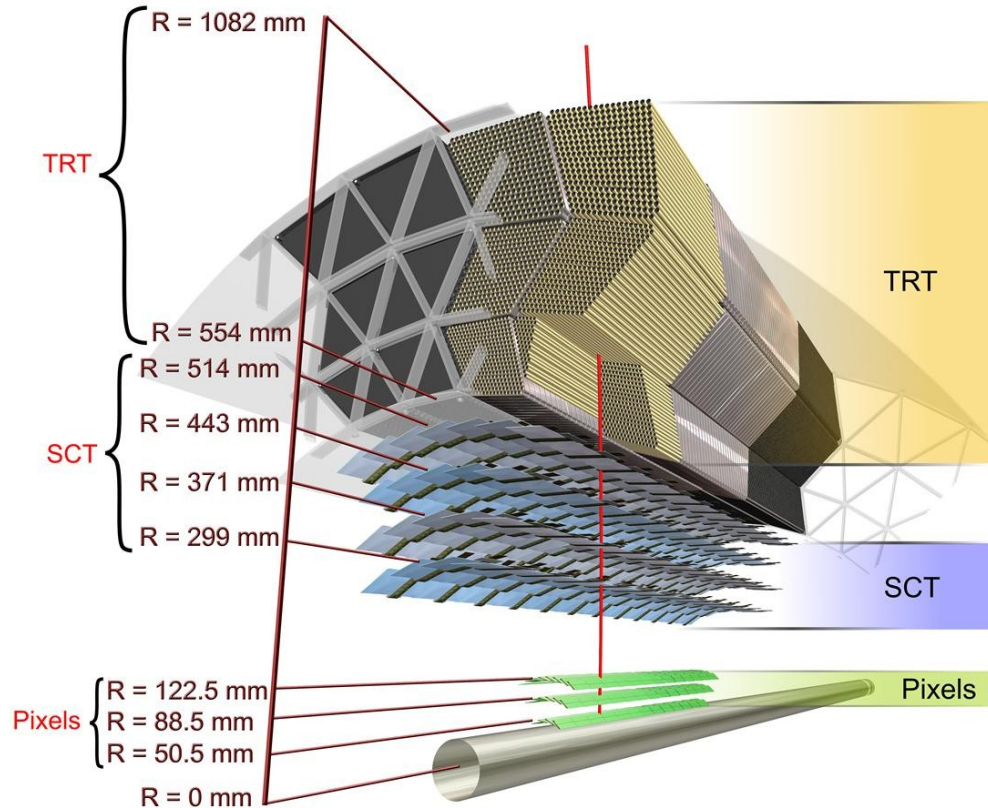

Reconstructed cosmic muon crossing the ID with Solenoid Field on.

Overall:	Pixels	95% of the modules run stable (and improving every day)
	SCT	99.8% barrel and 97.6% end-cap modules in operation
	TRT	98% read out (2% dead channels from assembly and installation)

All ID sub-detectors integrated in the ATLAS DAQ before first beam and took significant amount of data.



Calorimeters

Coverage $|\eta| < 5$

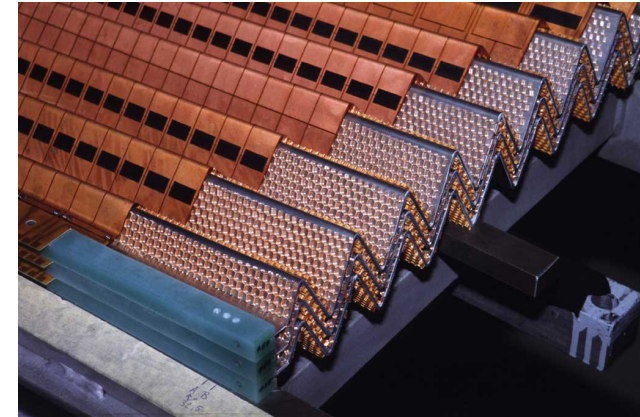
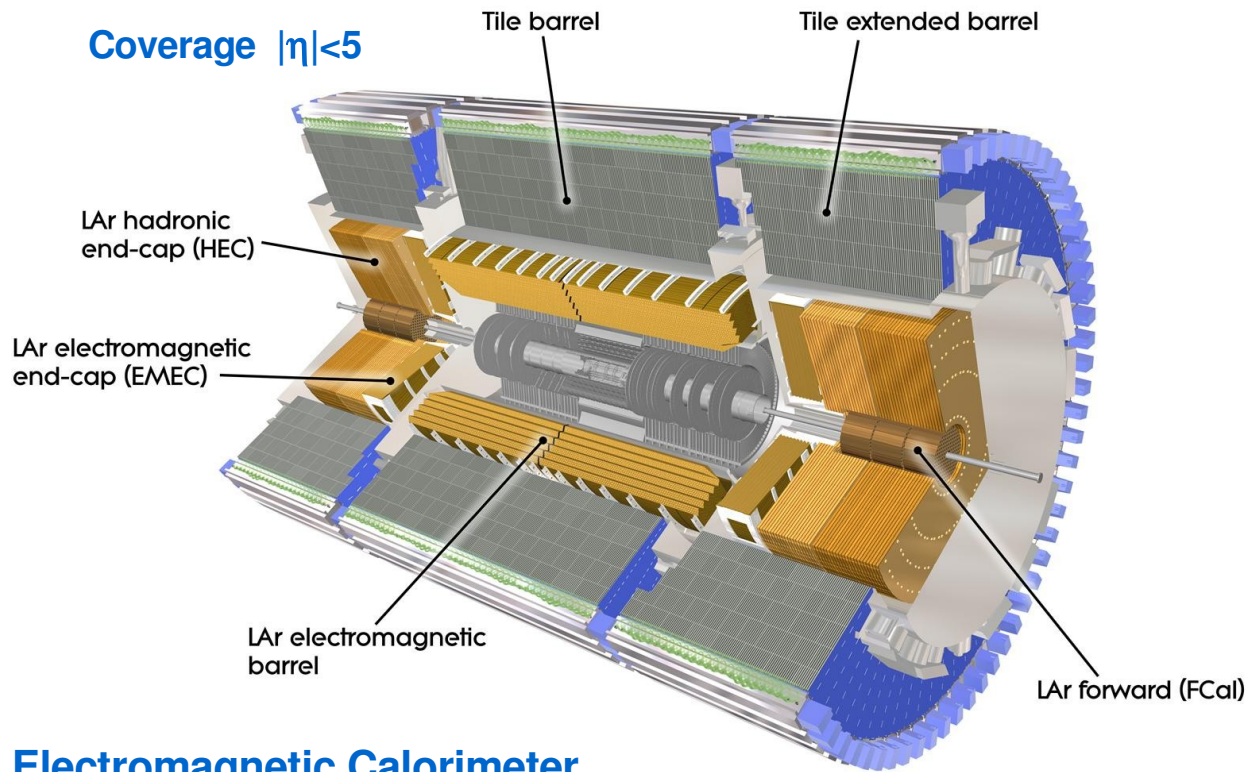

Accordion structure of LAr barrel



TileCal fibers guiding the light from the scintillators to the PMTs

Electromagnetic Calorimeter

barrel, end-cap: Pb-LAr

$\sigma/E \sim 10\%/\sqrt{E}$ energy resolution e/γ

180'000 channels: longitudinal segmentation

Hadron Calorimeter

barrel Iron-Tile, EC/Fwd Cu/W-LAr (~20000 channels)

$\sigma/E \sim 50\%/\sqrt{E} \oplus 0.03$ pion (barrel)

$\sigma/E \sim 100\%/\sqrt{E}$ pion (end cap)

Trigger for e , jets, missing E_T , etc.



Calorimeters



LAr Status

Since May 2008, full calorimeter up, integrated in DAQ and slow control in steady running mode.

all channels read-out

~0.02 % dead (isolated) channels, plus 0.8% dead readout, including

1 of 8 HEC low voltage power supply off (need access for repair)

Commissioning on-going (cosmics and beam backgrounds)

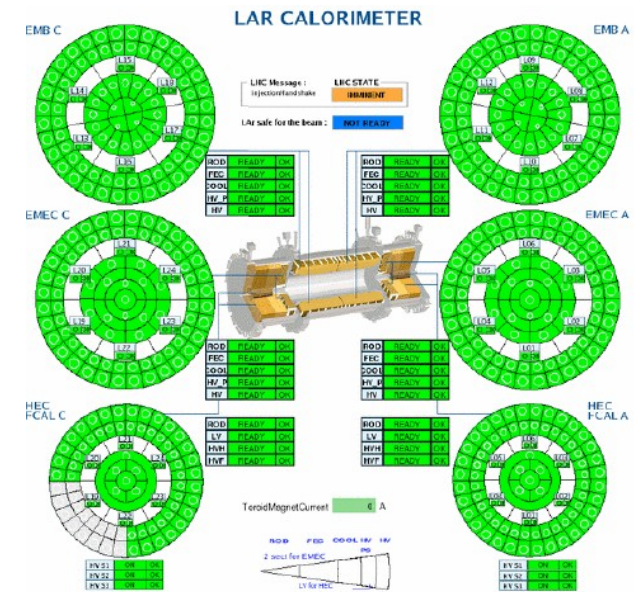

LAr Detector Status by first beam

TileCal Status

Full calorimeter up and running, integrated in DAQ

~10000 PMTs → 5000 cells

~0.2% dead (isolated) cells, and

2 of 256 modules off

1.4% of cells not usable for Physics will be repaired during shutdown with access

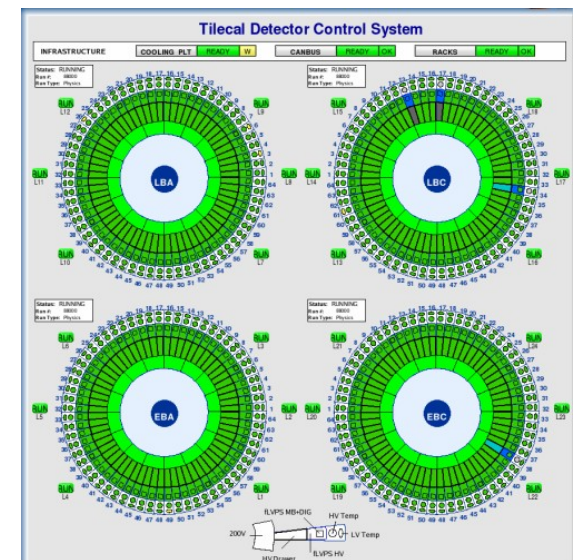

Tile Detector Status by first beam



Muons System Tracking

~1200 MDT precision chambers for track reconstruction (+ CSC)

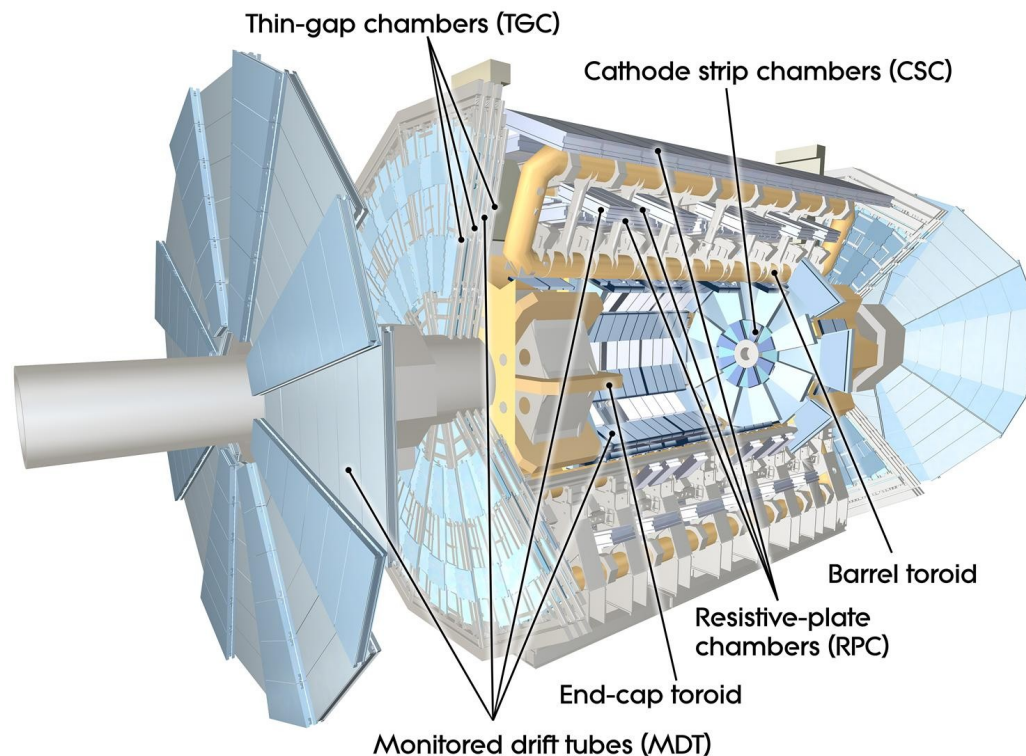
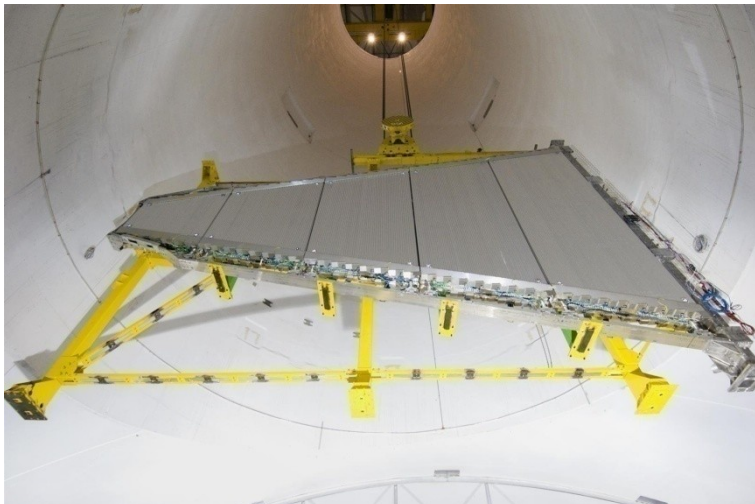

Toroid magnets peak field: 4 T

Stand-alone momentum resolution:

$\sigma(p_T)/p_T < 10\%$ up to 1 TeV

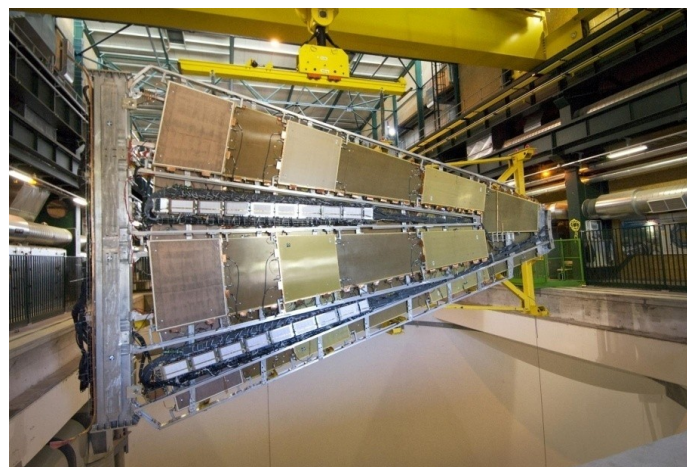

~600 RPC and
~3600 TGC trigger chambers



Muons Hardware Status

MDT

Problematic chambers: < 1%
(HV, read-out, gas)

Alignment

99.7% of the barrel, 99% of the end-cap alignment lines are working

RPC

- 16 sectors fully commissioned
- 3 sectors under final timing adjustments
- 2 sectors affected by missing CAEN HV
- 1 not ready (noise on clock propagation)

TGC

All wheels on both sides ready for operation
(need some HV for TGC on Small Wheel due to HV failure and shortage of spares)

CSC

Chambers work, but read-out limitation being worked on

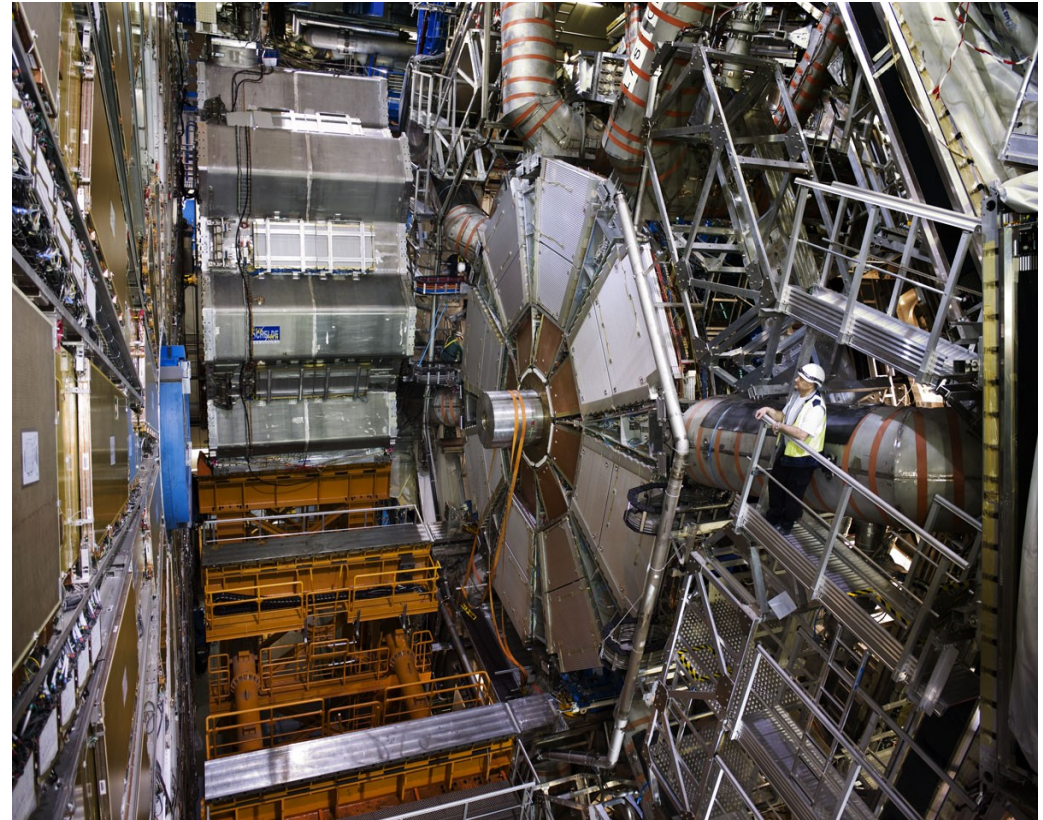

Insertion of the End Cap toroid magnet between the small wheel and the big wheel



Trigger System

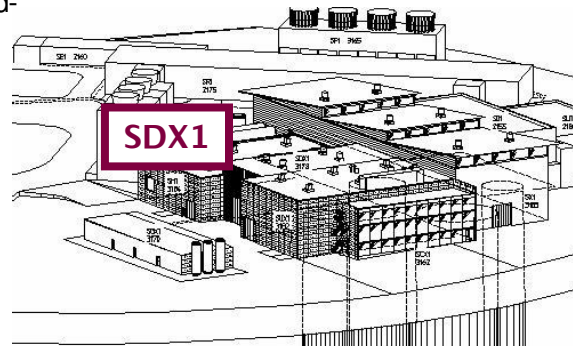
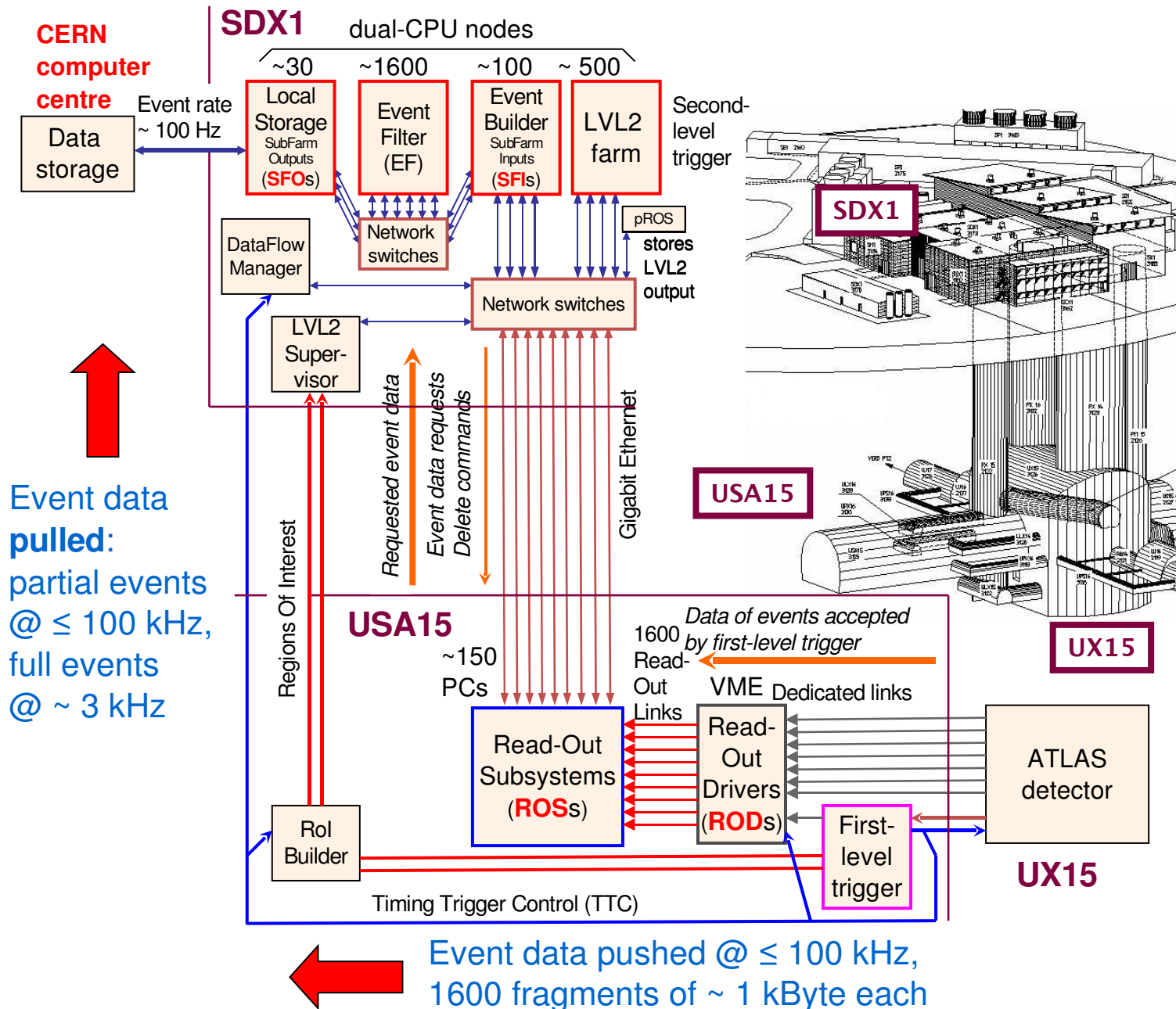

HLT Farm

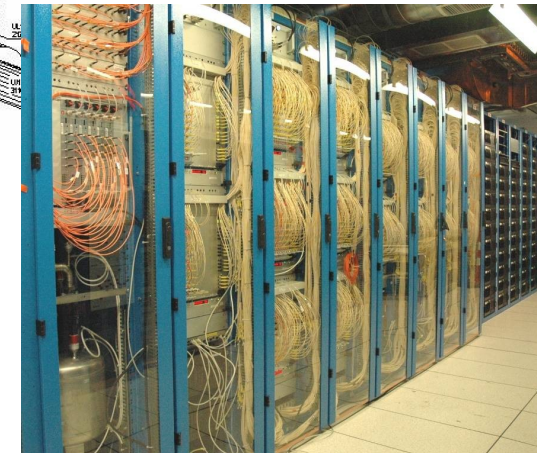
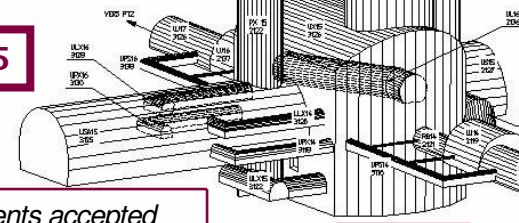

Read-out electronics



Detector Commissioning

- **Basic detector functionality**
 - Cabling/mapping
 - Dead/inefficient channels
 - Noise/occupancy
- **Readout/trigger chain**
 - full Level-1/TDAQ/online/offline chain
 - Interfaces between e.g. DAQ, detector control system, databases
- **Signal**
 - Signal reconstruction
 - Timing
 - Alignment
- **Calibration**
 - Test/Exercise the procedure
 - Initial Calibration Constants

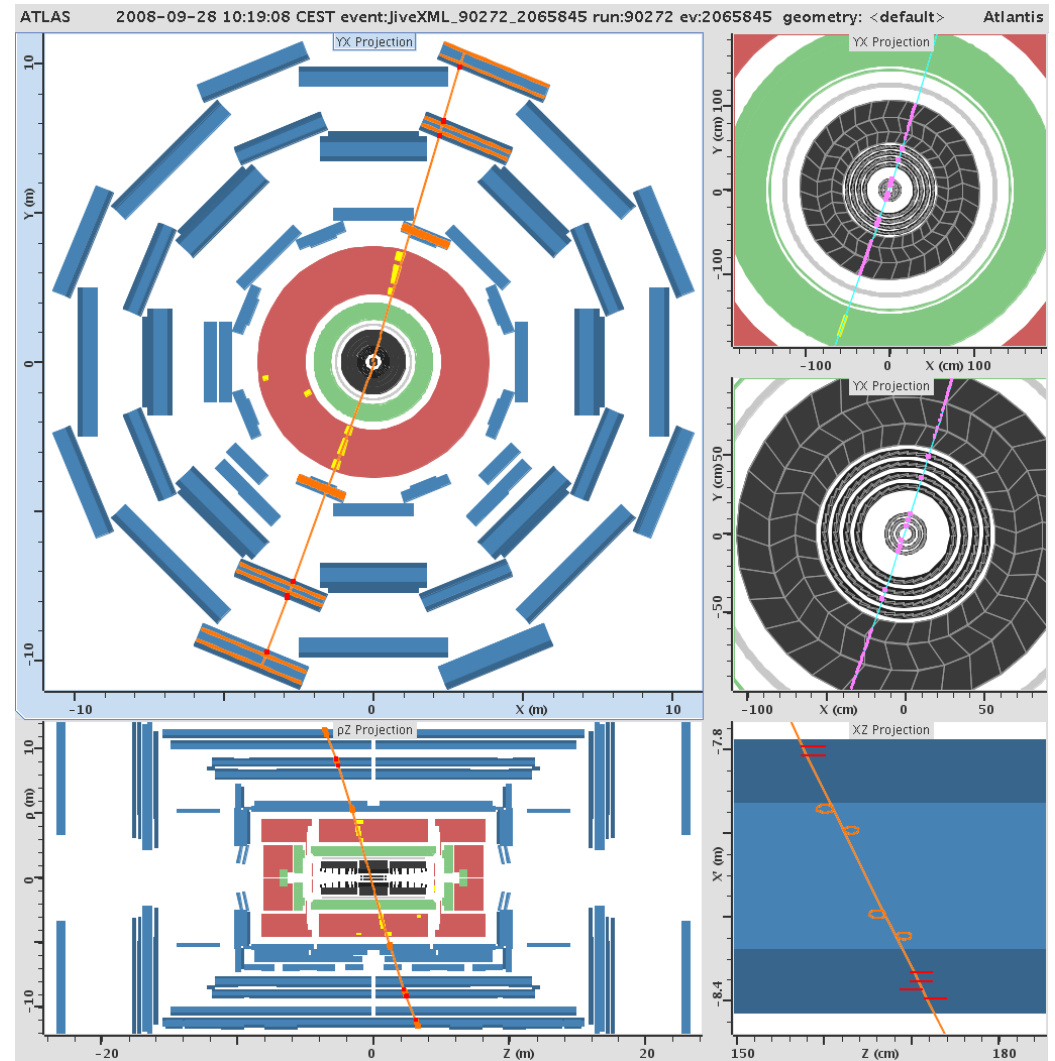

Reconstructed cosmic muon crossing the whole detector



Cosmics Statistics



- **Combined commissioning with cosmics started in December 2006**

Atlas went through 8 combined data taking sessions of 1-2 weeks each, called Milestone weeks.

They were fundamental in order to integrate the detectors and test the online data acquisition.

The cosmic data collected at present is very important for the detector commissioning:

- High statistics.
- Stable running conditions.
- All detector and detector parts in.

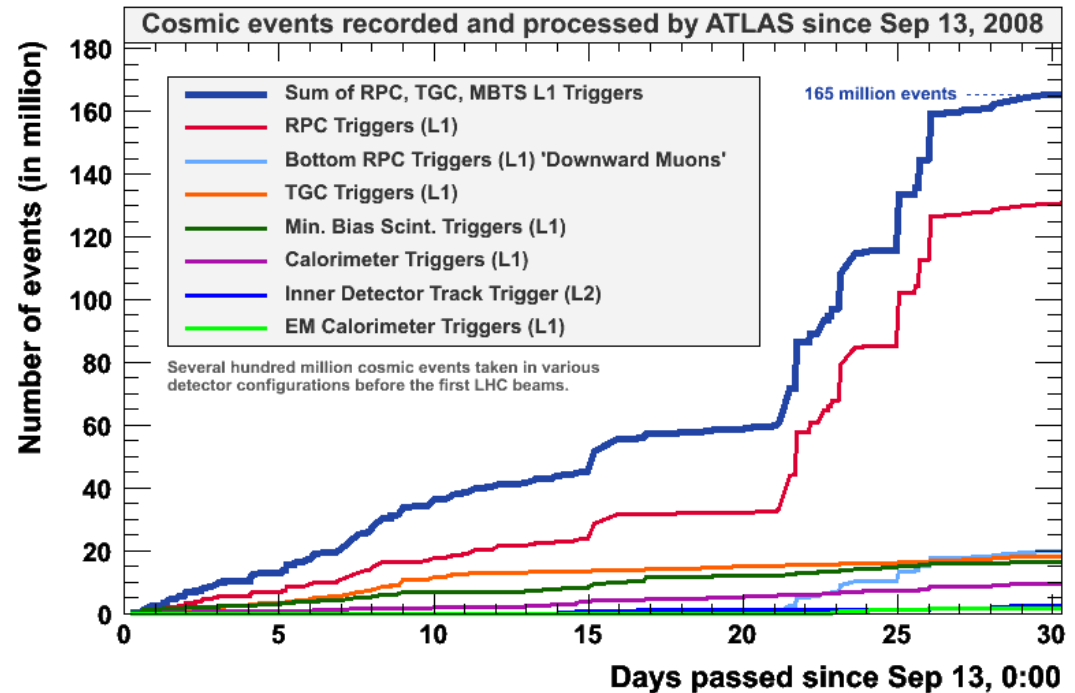

Cosmic events recorded since 13th of September

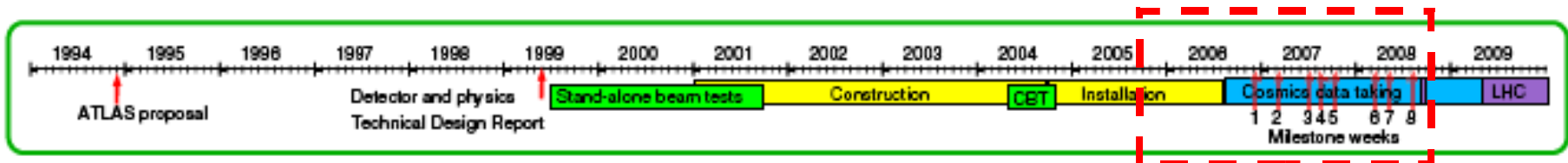



LHC First Beam



LHC beam was circulated in ATLAS the 10th September 2008, stopped at each collimator, realigned and continue.
 Only 1 bunch of $2 \cdot 10^9$ protons at the same time of 450 GeV of energy.

RF capture of beam on day2!

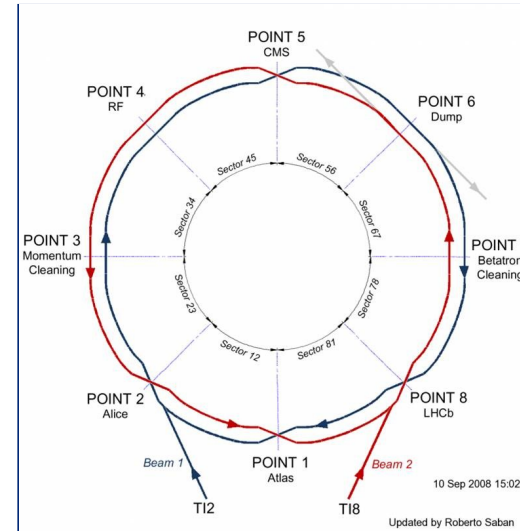

LHC ring

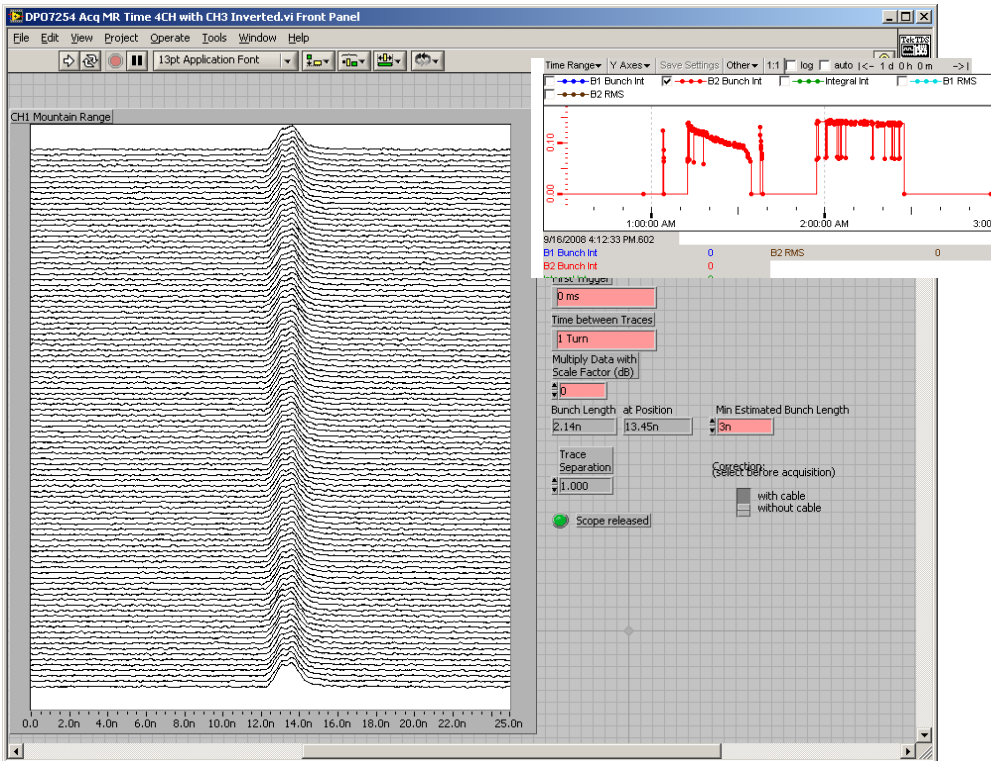

Beam profile of the RF captured beam

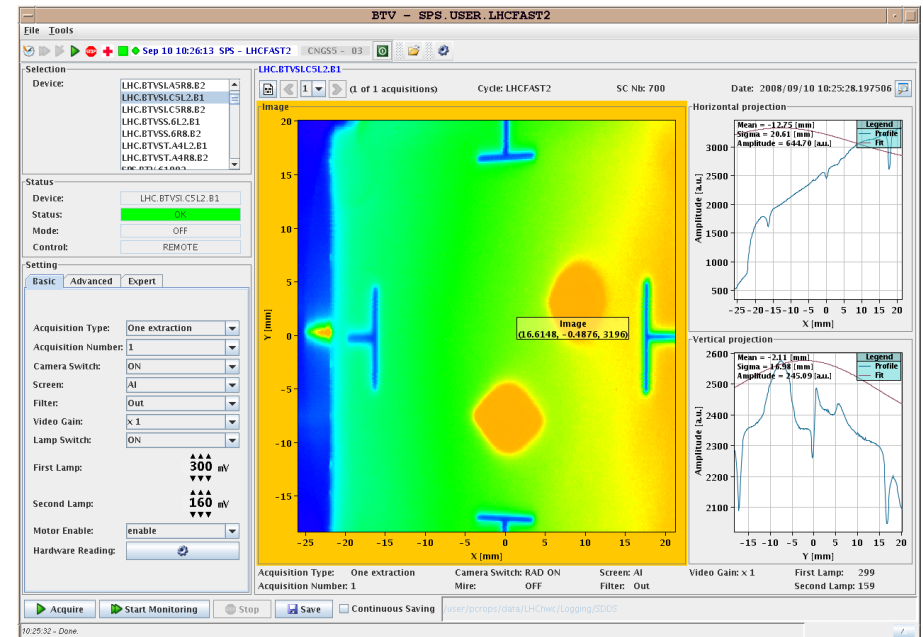

LHC Beam profile



LHC First Beam in ATLAS



The very first beam-splash events from the LHC in ATLAS, 10th September 2008!
Successfully triggered by the L1Calo and MBTS triggers.

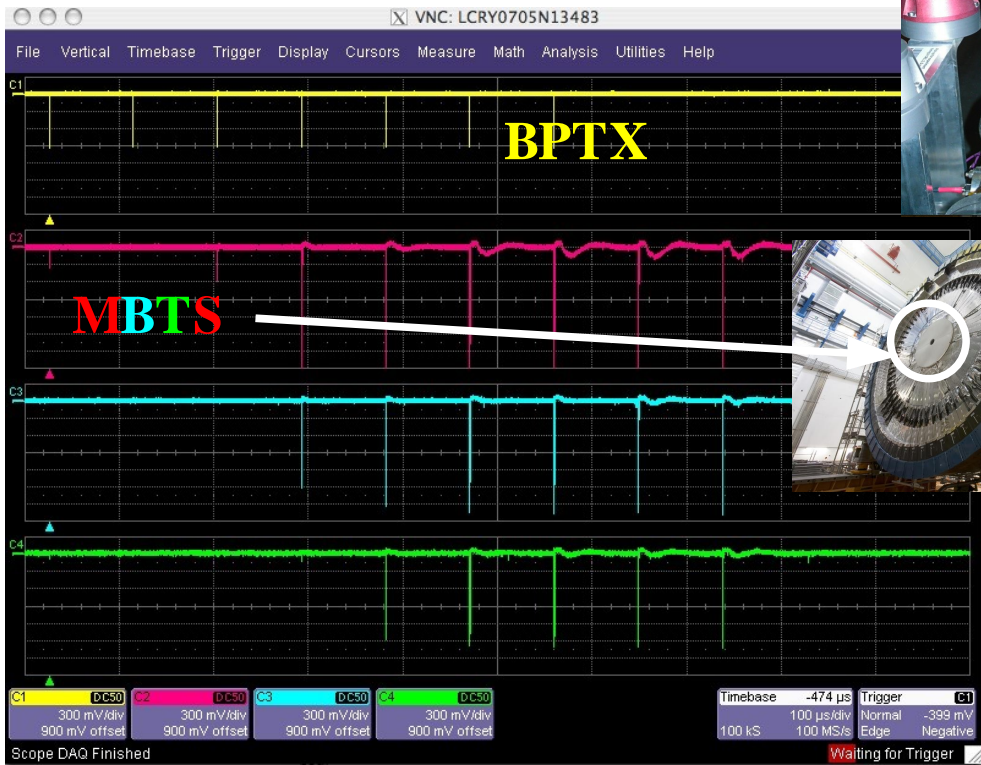
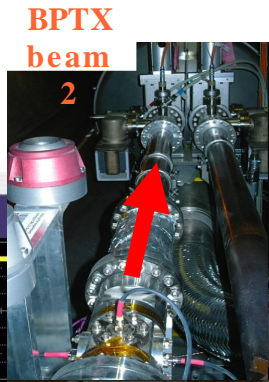

Atlas Control Room by the first splash event

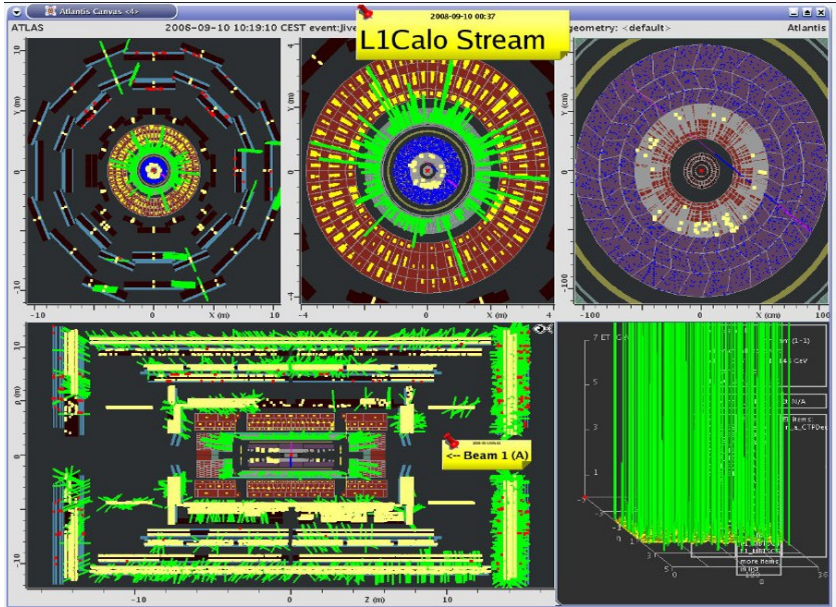
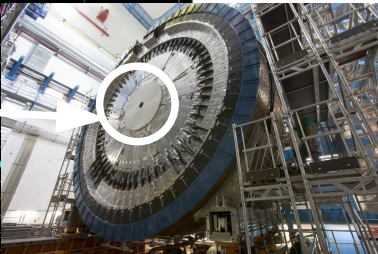

First splash event on the screen the 10th Sep

BPTX and MBTS signals of circulating beams



LHC First Beam in ATLAS

Good correlation between LHC injection and beam events recorded by Atlas.
First M&C bottle delivered! The others 2 will have to wait for 2009.

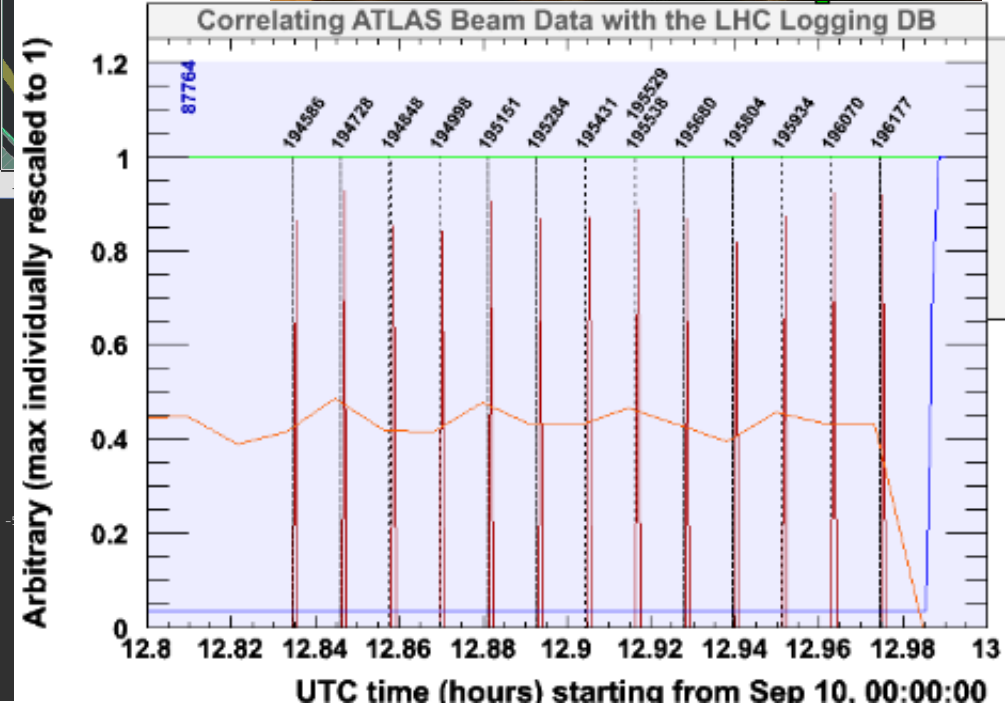
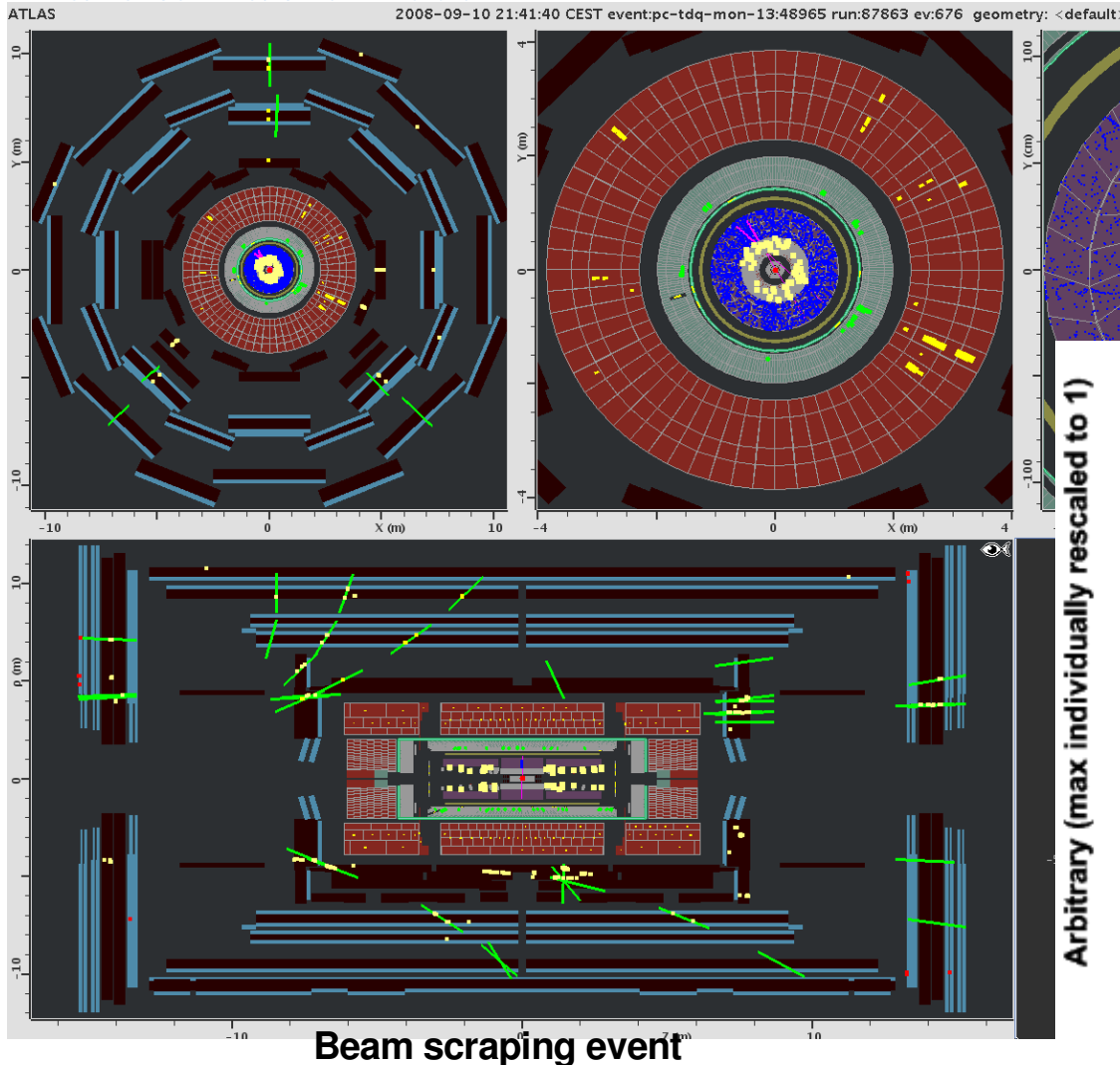



ID Commissioning with Cosmics



pT Spectrum of Cosmic muons in different trigger streams

あて白の式, ~80K 桁の式

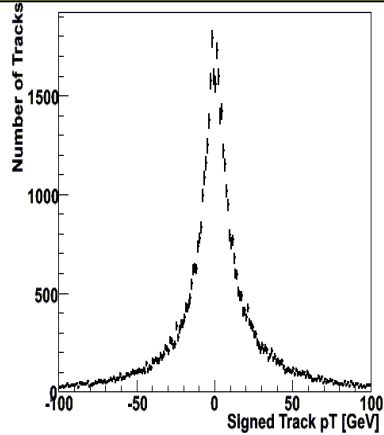

Run 90272, 1/physics_IDCosmic
/InnerDetector/IDAlignment/Tracks_NoTriggerSelection/GenericTracks/pT

ナ並て白の式, ~1K 桁の式

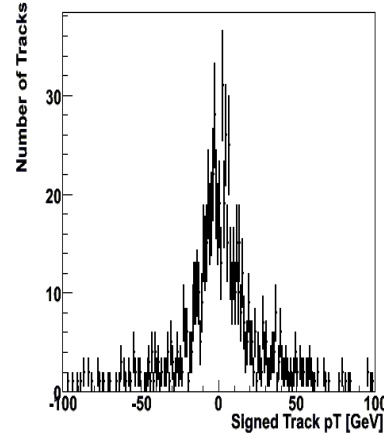

Run 90272, 1/physics_CosmicMuons
/InnerDetector/IDAlignment/Tracks_NoTriggerSelection/GenericTracks/pT

ナ並て, ~17K 桁の式

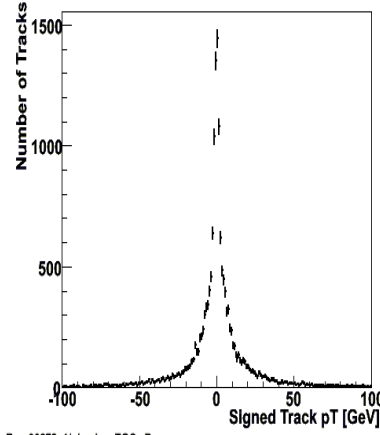

Run 90272, 1/physics_TGCwBeam
/InnerDetector/IDAlignment/Tracks_NoTriggerSelection/GenericTracks/pT

内βナウ, ~2K 桁の式

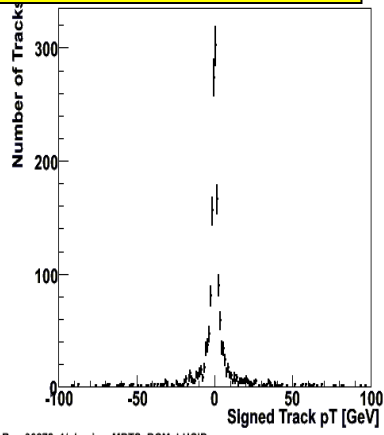

Run 90272, 1/physics_MBTs_BCM_LUCID
/InnerDetector/IDAlignment/Tracks_NoTriggerSelection/GenericTracks/pT

よて白の, ~19K 桁の式

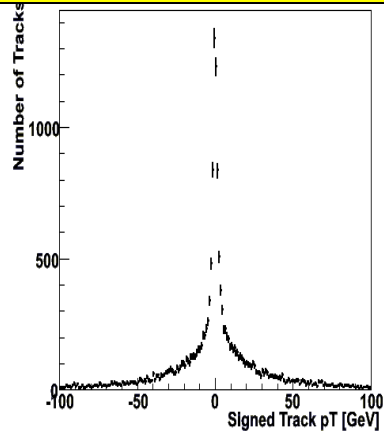

Run 90272, 1/physics_L1Calo
/InnerDetector/IDAlignment/Tracks_NoTriggerSelection/GenericTracks/pT

アPて, ~33K 桁の式

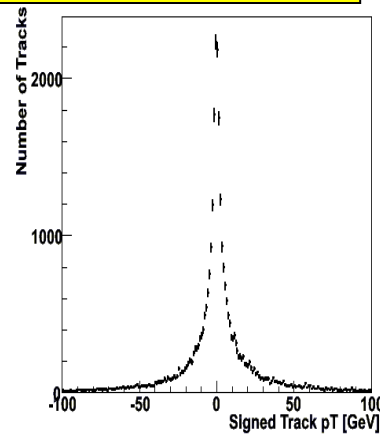

Run 90272, 1/physics_RPCwBeam
/InnerDetector/IDAlignment/Tracks_NoTriggerSelection/GenericTracks/pT

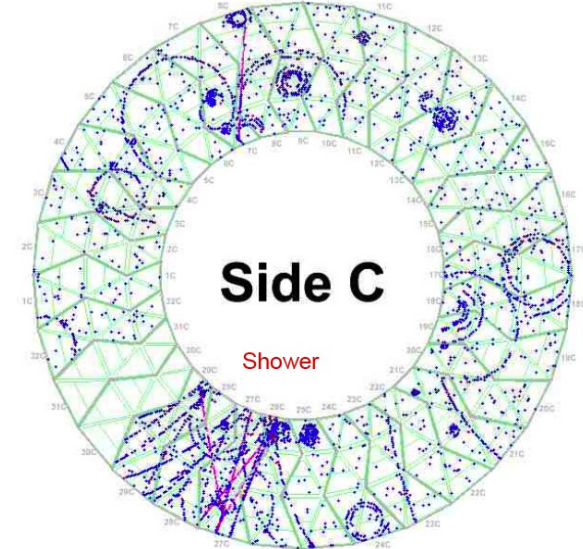

Cosmic shower in the TRT with solenoid ON

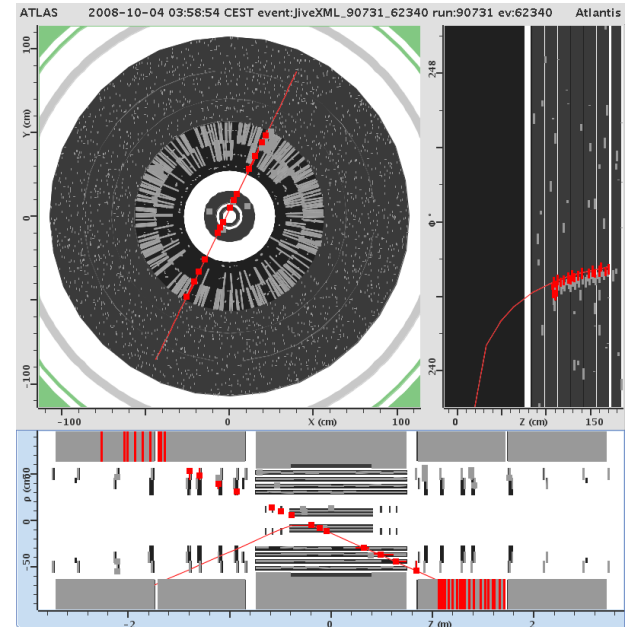

Barrel + End Cap SCT+ Pixel track

Statistics collected in 15 hours



Inner Detector Efficiency



measurements per possible hit vs. layer in the barrel

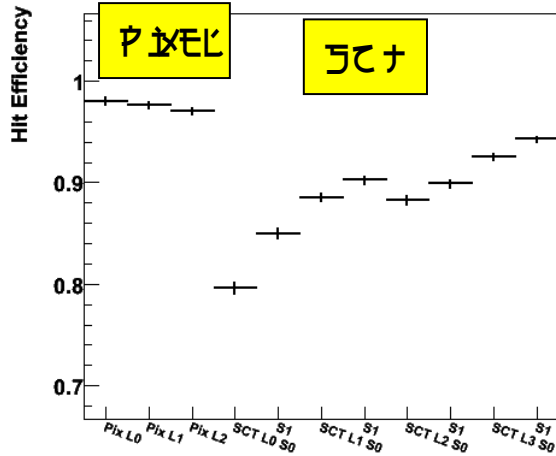

Ratio hits to total measurements vrs phi sector for TRT Barrel layer 0

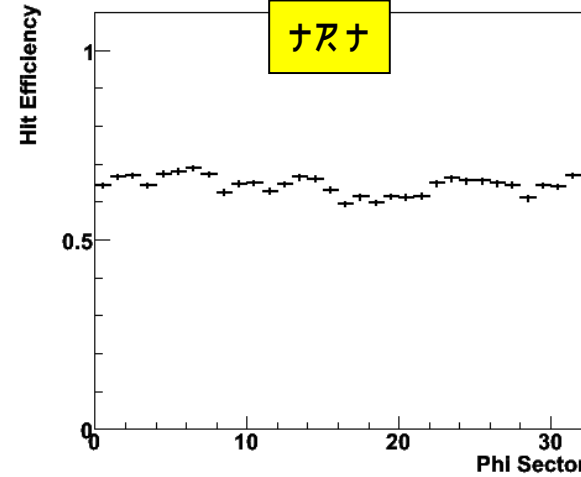

Run 90733, 1/physics_IDCosmic
/InnerDetector/IDAlignment/Tracks_NoTriggerSelection/HitEfficiencies/measurements_

Run 90733, 1/physics_IDCosmic
/InnerDetector/IDAlignment/Tracks_NoTriggerSelection/HitEfficiencies/hits_eff_vs_phi

Efficiency for hits on tracks

- Pixel efficiency looks good at first glance
- SCT efficiency under investigation
- TRT efficiency will improve with updated calibration
- ID (SCT+TRT) tracks angle correlation with Muon System (MDT) tracks is in agreement with Monte Carlo distribution

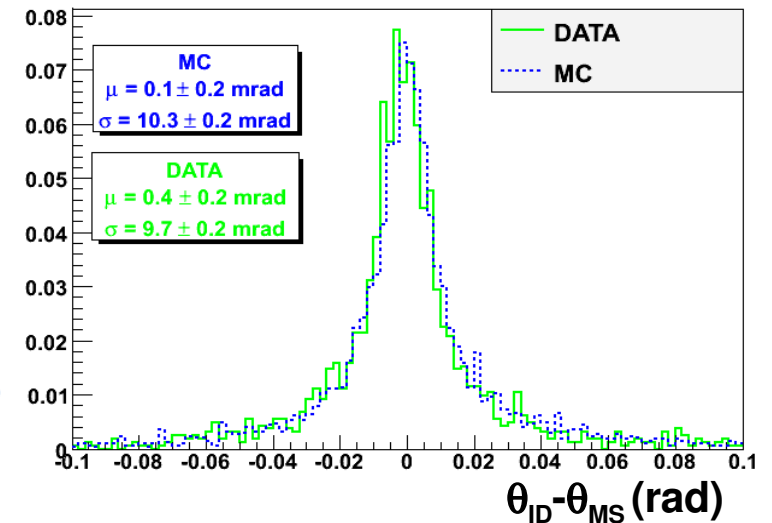

ID and MS track angle correlation



Inner Detector Alignment

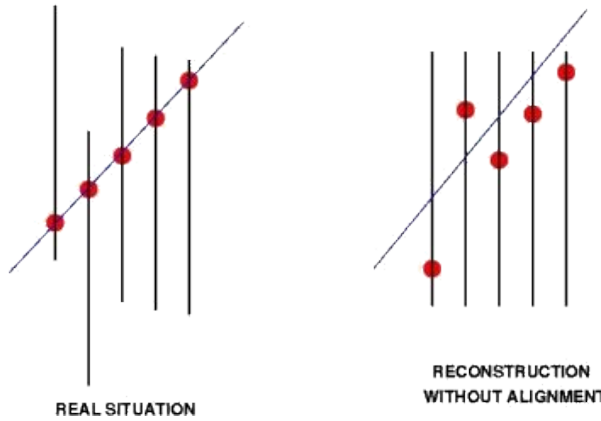

Deduce alignment corrections from track fit quality by minimizing residuals

$$\chi^2 = \sum_{\text{hits on tracks}} r^T V^{-1} r$$

Covariance matrix V residual vector r

At the moment used for cosmics:

- Global χ^2 algorithm
- Pixel-stand-alone algorithm

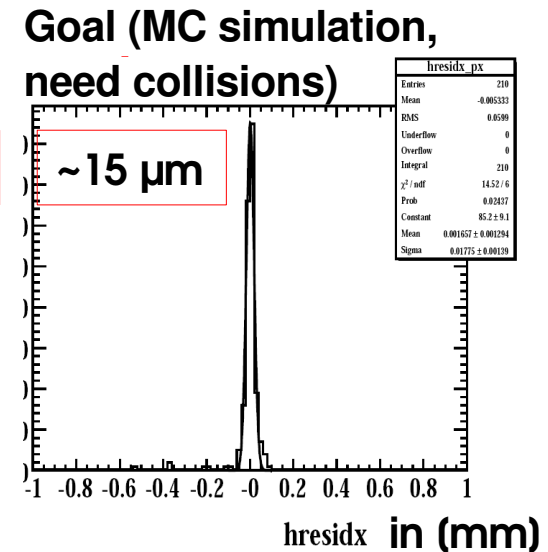
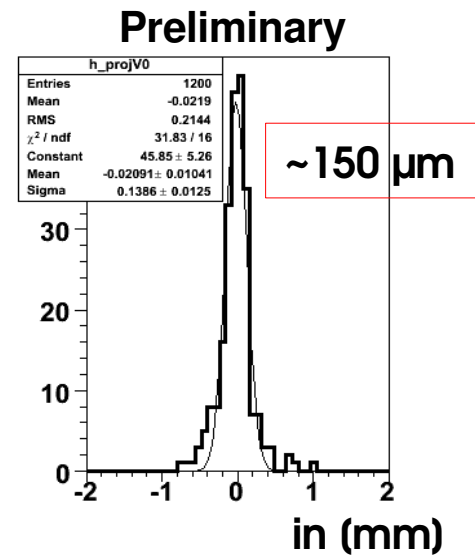
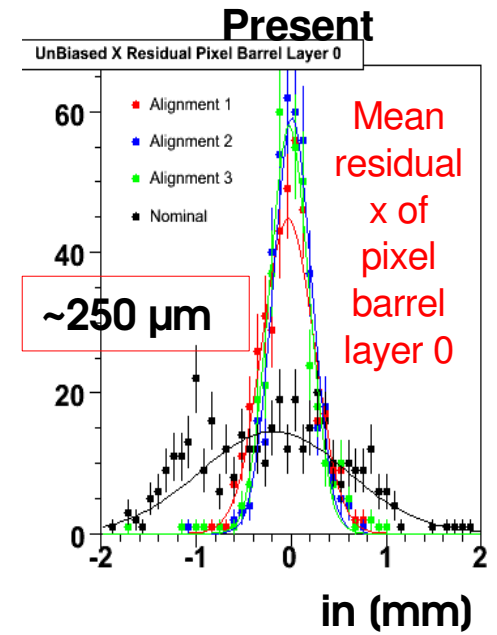
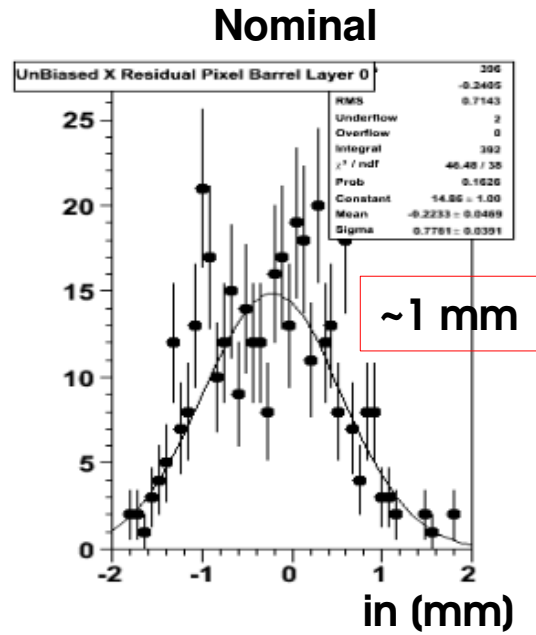



Inner Detector in Beam events

- **Splash events:**

- Tracking technically runs
- In the beginning SCT kept with low voltage settings and Pixels off for detector safety reasons

- **Beam Halo/Gas events:**

- SCT and TRT running correctly
- Non pointing (cosmic) track finder algorithm more efficient

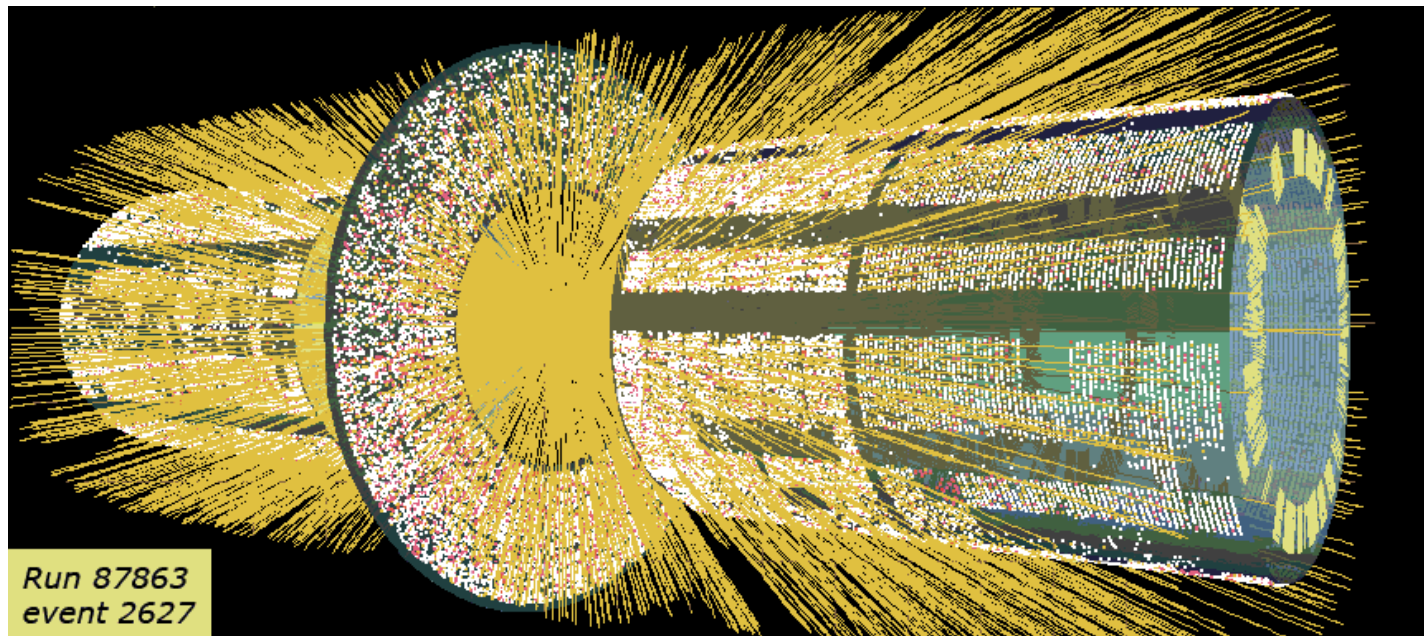

ID hits and track segment in a splash event

Calorimeter Commissioning

Calorimeter commissioning: 3 years

- LAr: Some channels require special corrections e.g. high voltage
- Tile: Cs source used to set HV and equalize PMT gains to $<1\%$ (at present 6% due to nominal Cs source intercalibration)
- Tile timing corrections: can intercalibrate to 0.5ns (goal is 5ns for first collisions)
- Effort is now more focused on performance
 - Long term stability
 - Prediction of the signal
 - **Finalize Calibration constants**

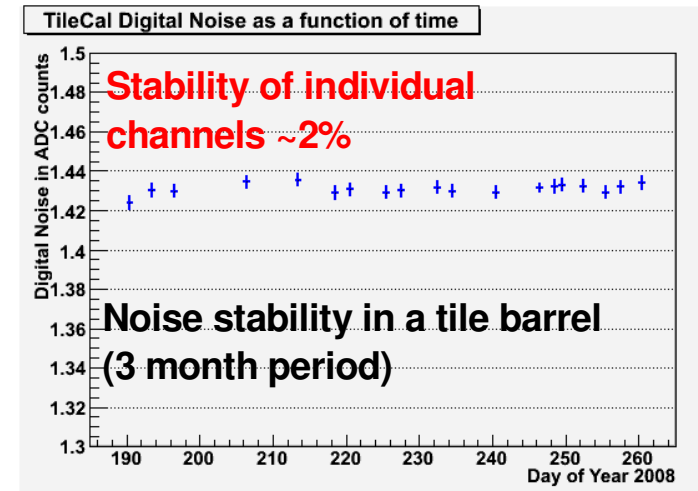
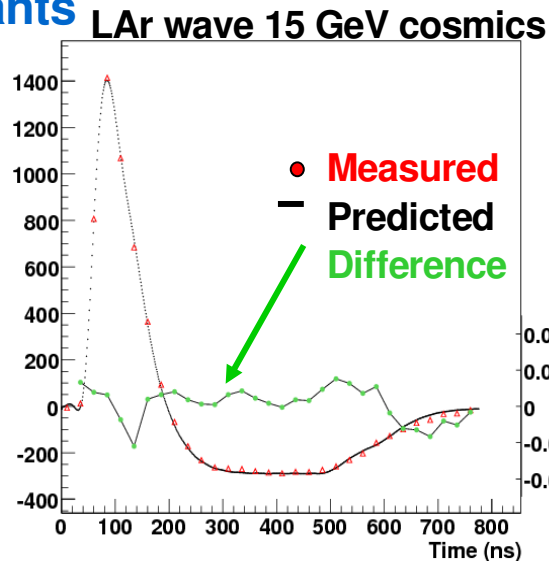
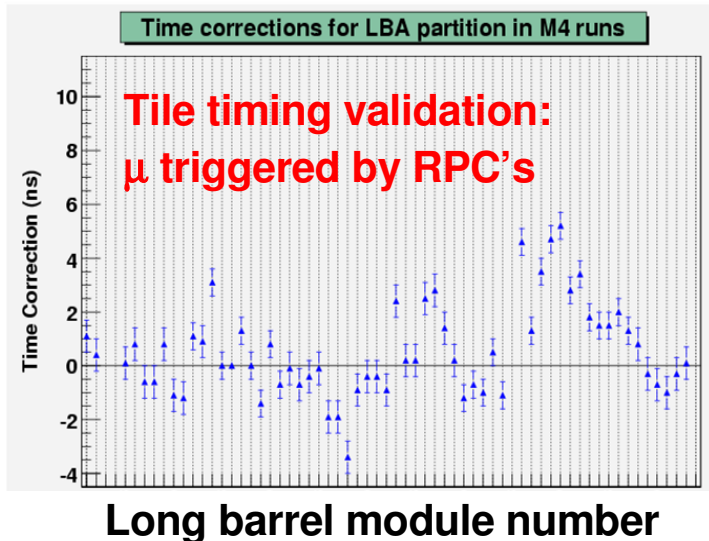
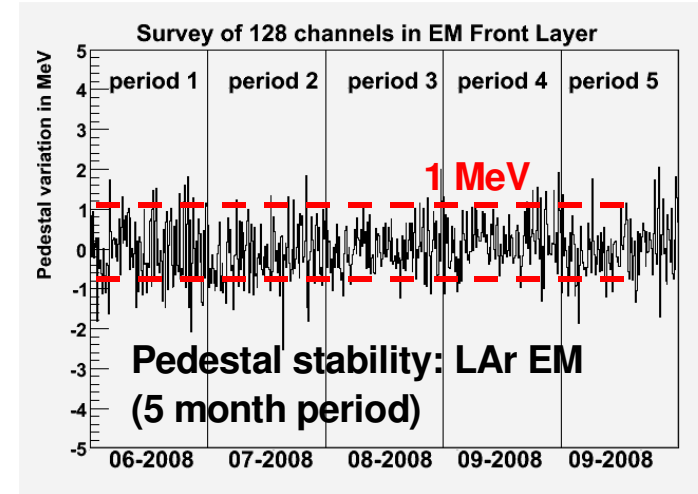



Calorimeter Performance



- **Energy reconstruction**
 - **LAr EM:** Reconstruct E with 3x3 calorimeter cells, comparison to Landau
 - ➔ energy η dependence agreement, though there is a 5% systematic uncertainty on the MC prediction
 - **TileCal:** energy loss by muons normalised by distance traveled in TileCal

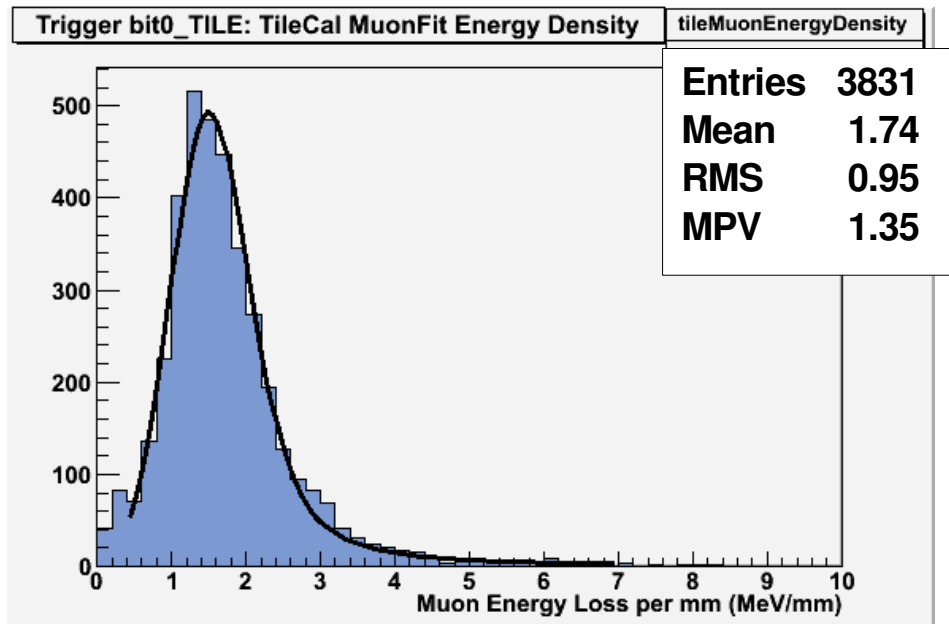

Energy loss of Muons in TileCal

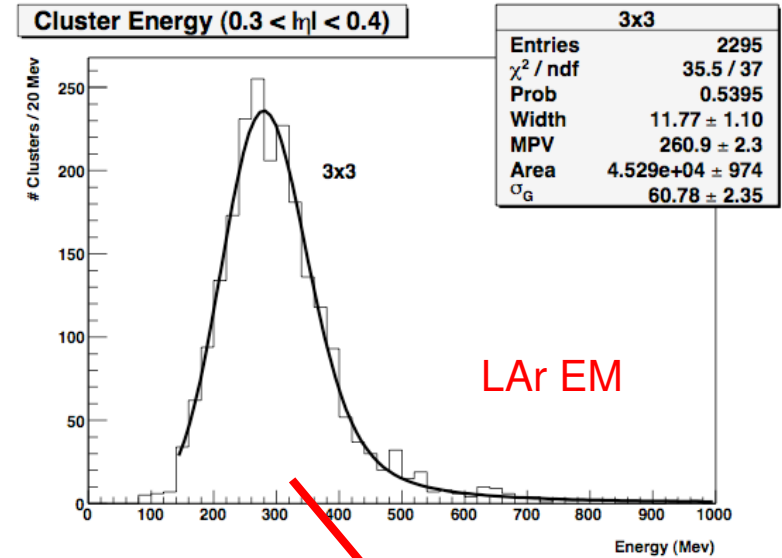

LAr EM

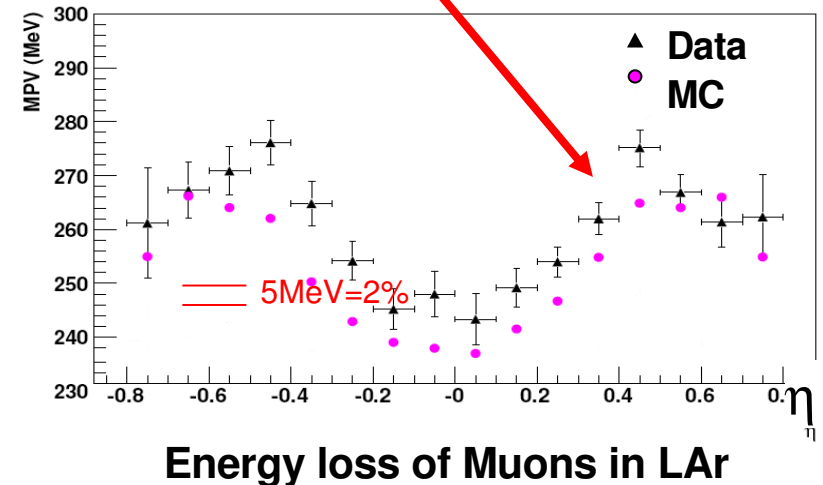



Calorimeter in Splash events

The events of Beam Splash on the collimator are the first kind of beam events recorded in Atlas.

- The total energy recorded in the Calorimeters for these events is **above 1000 TeV**.
- The width of the pulse shapes is consistent with the hypothesis of particles coming within 1-2 bunch crossing.

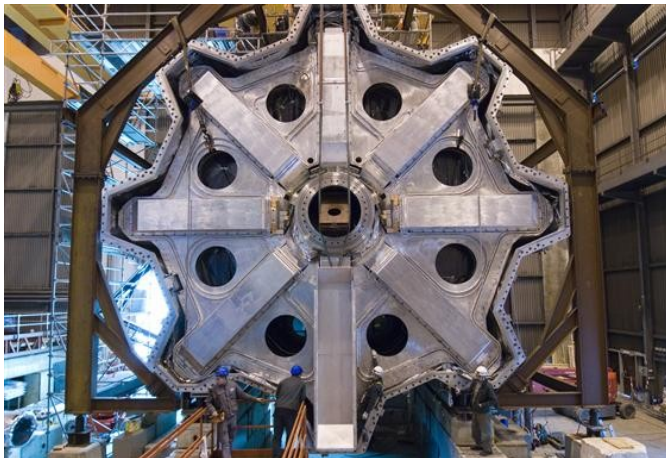
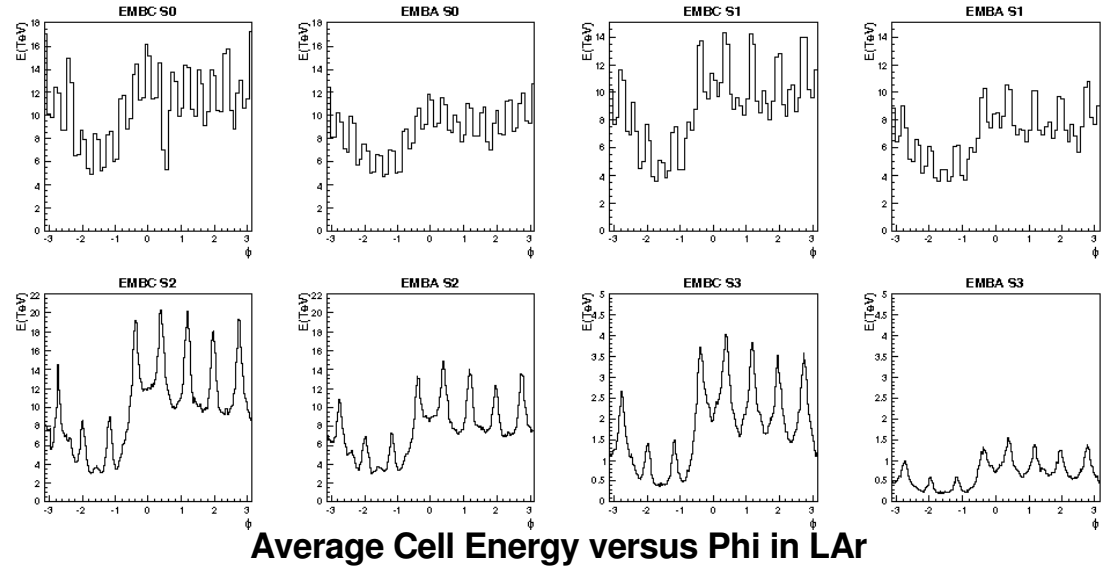

End Cap Toroid

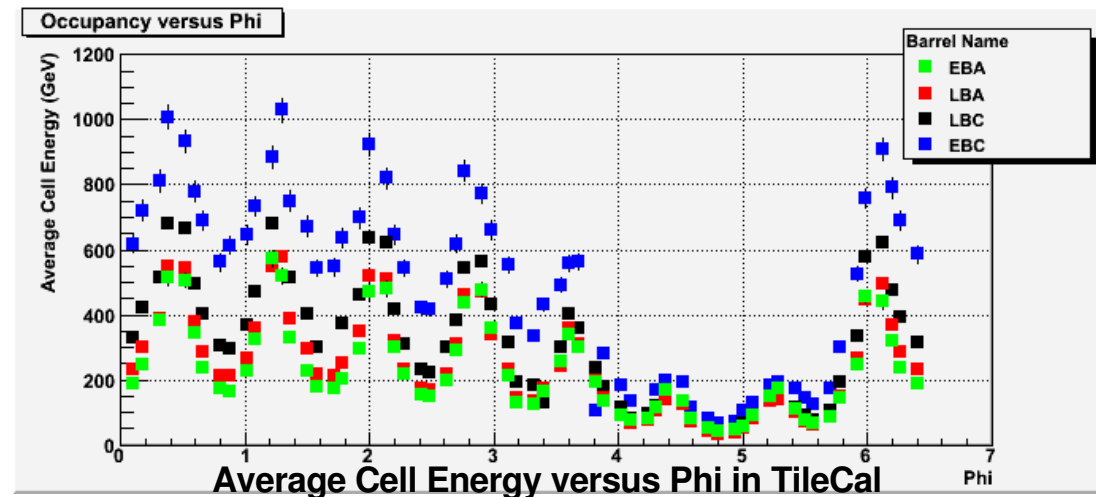

Splash events show an eight-fold structure and an up-down asymmetry, due to the EC toroid magnet and beam-line support material in front of it, also observed by other sub-detectors.

Beam Scraping Events

The events of Beam Scraping originate from the proton collisions due to the defocusing of the beam, before RF capture was activated.

- For these events the total energy recorded in TileCal is below 100 GeV, which corresponds to less than 10 muons per event crossing the detector horizontally.

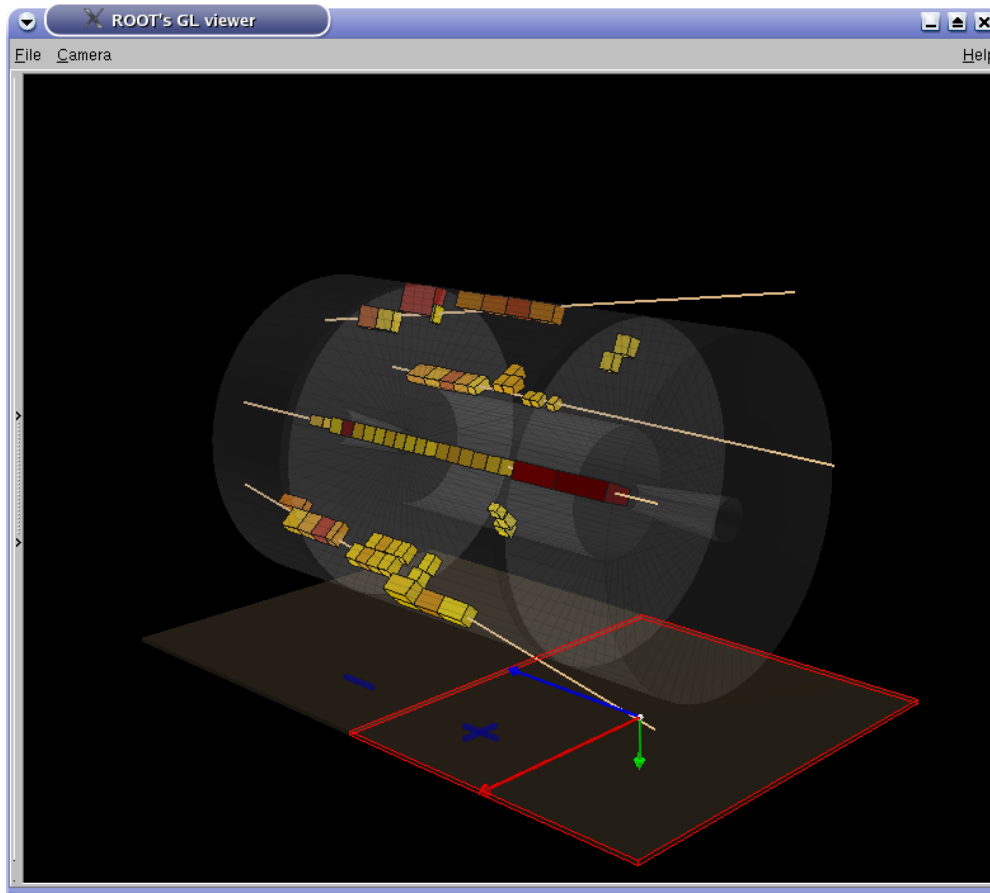

Beam scraping events in TileCal

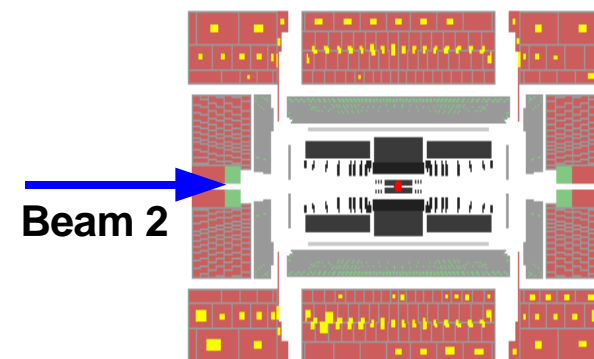
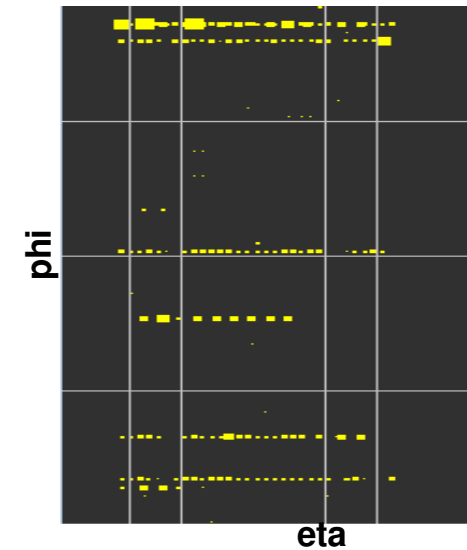



Beam Events: TileCal Timing

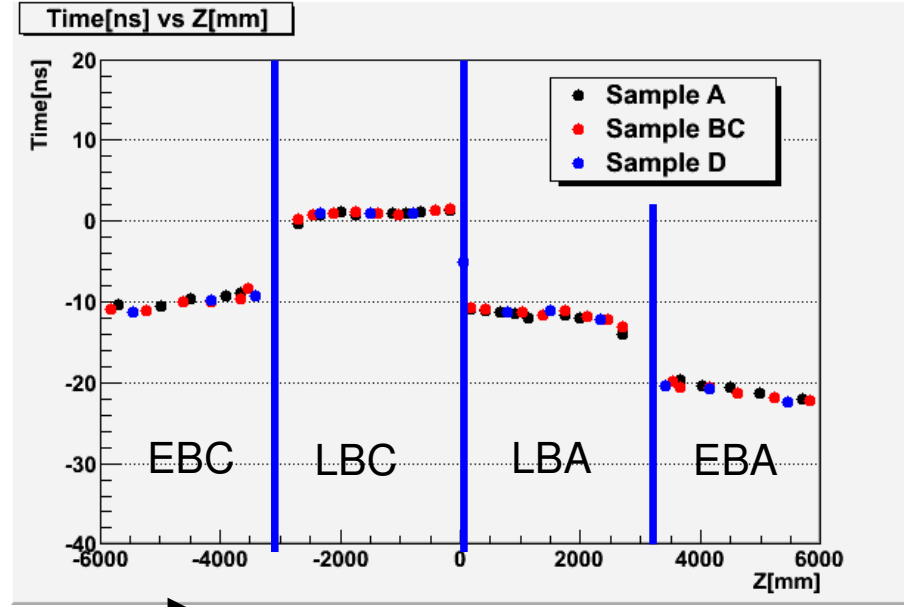
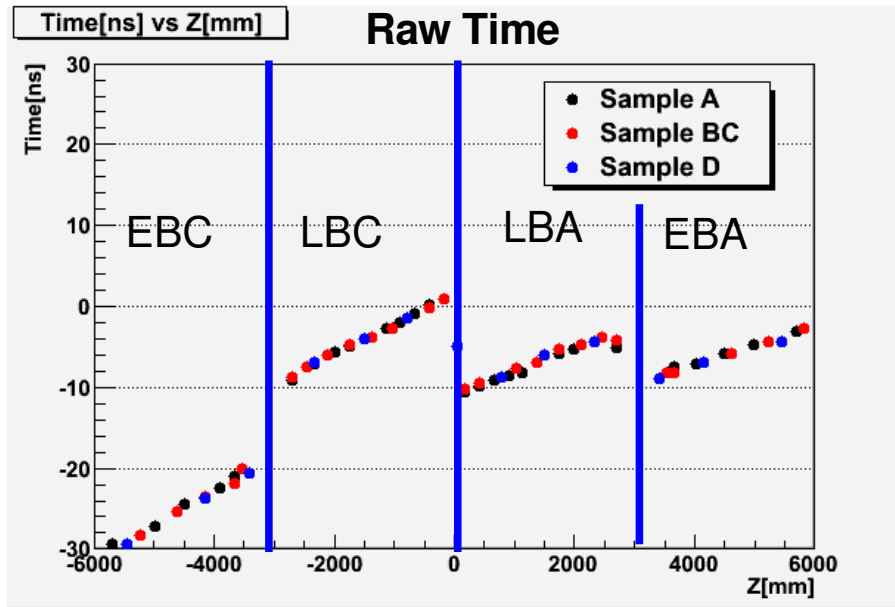

Time of Flight correction applied

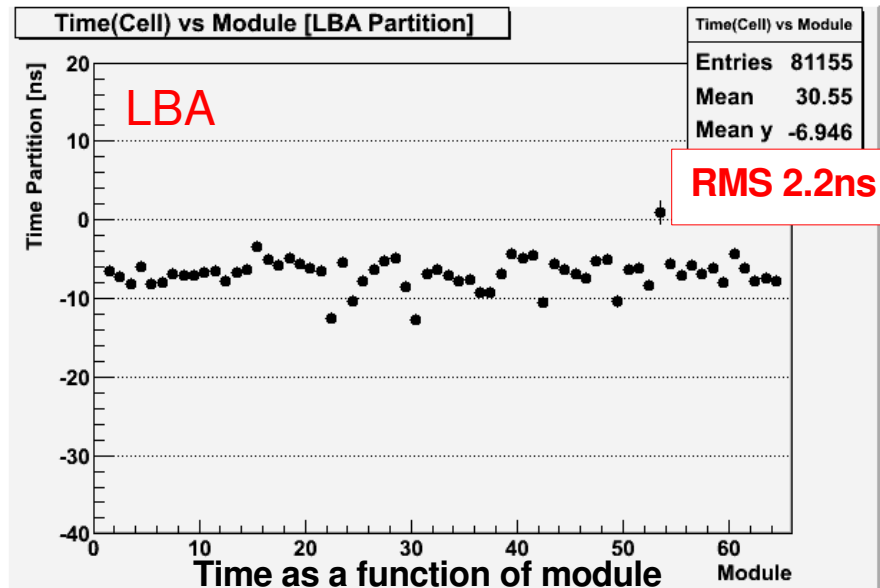

Time dispersion in each barrel is of the order of 2ns.

All off-sets between barrels well within 1 bunch crossing!



Beam Events: LAr Timing

Distribution of $\langle t_{\text{cell-tevt}} \rangle$ (one entry per cell EMB-C Layer2)

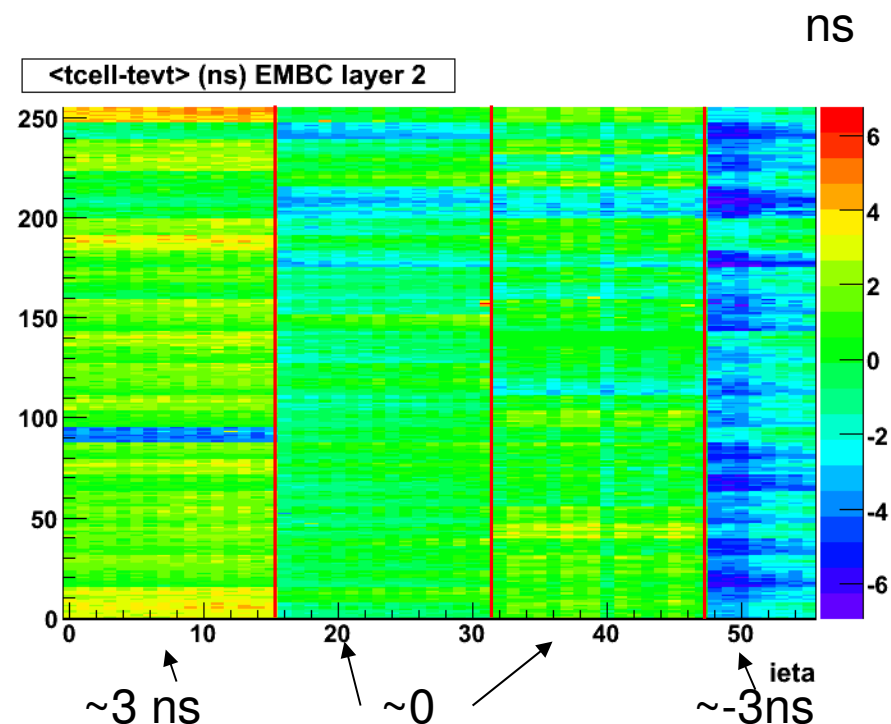
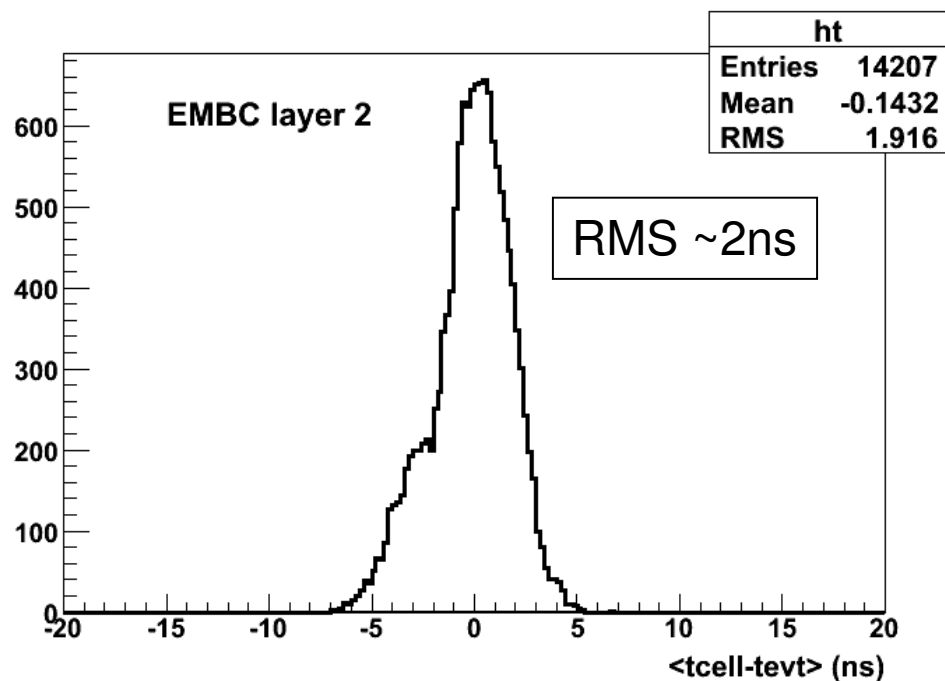

- Statistical accuracy of relative timing from splash events can be < 1 ns
- Time dispersion of ~ 3 ns



TileCal Energy response

- Beam Scraping events were analyzed to check the Cesium calibration and testbeam analysis.

- **Good agreement** of detector response to beam muons between the calorimeter's samples.
- Barrels responses compatible within 6%

dE/dz for muons is:

1.9 ± 0.2 MeV/mm

This value is in agreement with the muon energy loss per mm measured with cosmic muons:

$dE/dz = 1.7 \pm 0.3$ MeV/mm

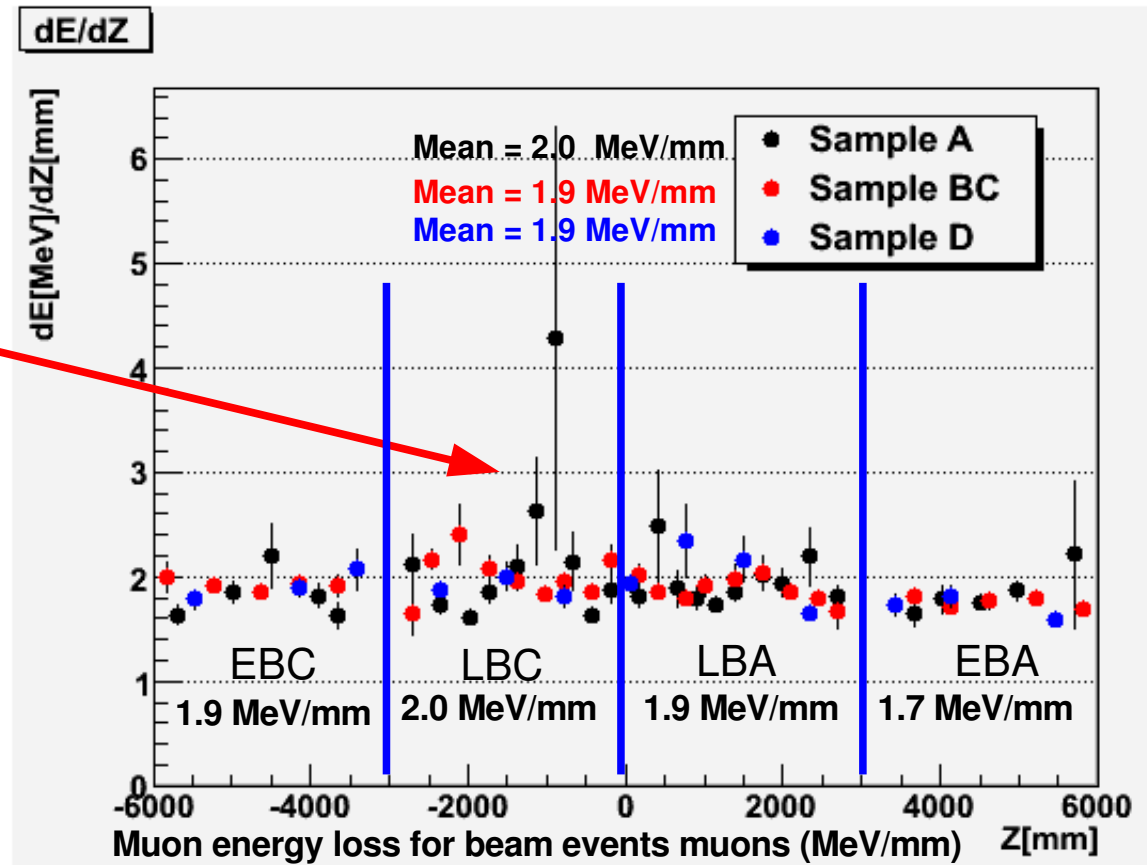

- And also **Good agreement** of the detector response between cosmic data and beam data



Muon Commissioning

MDT detect cosmic muons tracks very well

- ~6 hits per layer per track

Combined MS+ID (TRT+SCT) in March 2008

- difference in track (θ, ϕ) using ID (SCT+TRT) and muon (MDT) hits

August 2008 cosmics run with magnetic field "on":

- Correlation between momentum in ID (TRT only) and muon spectrometer

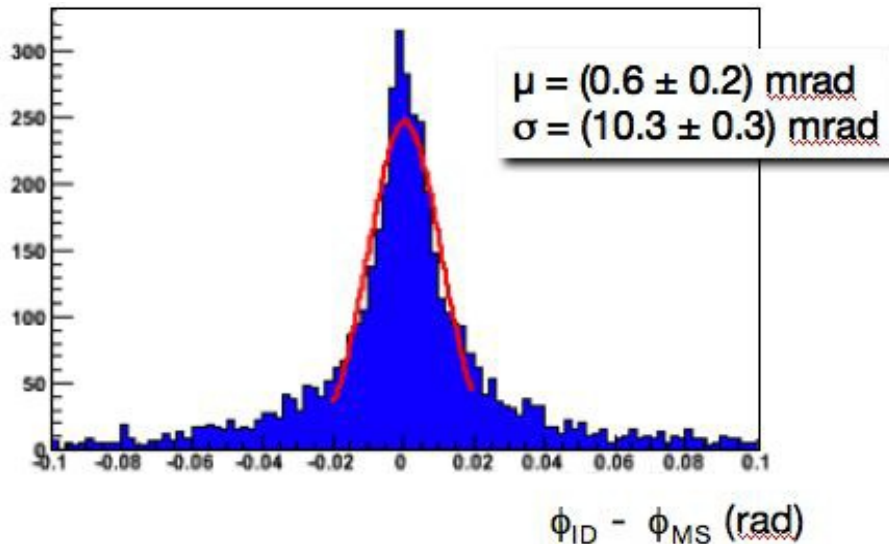
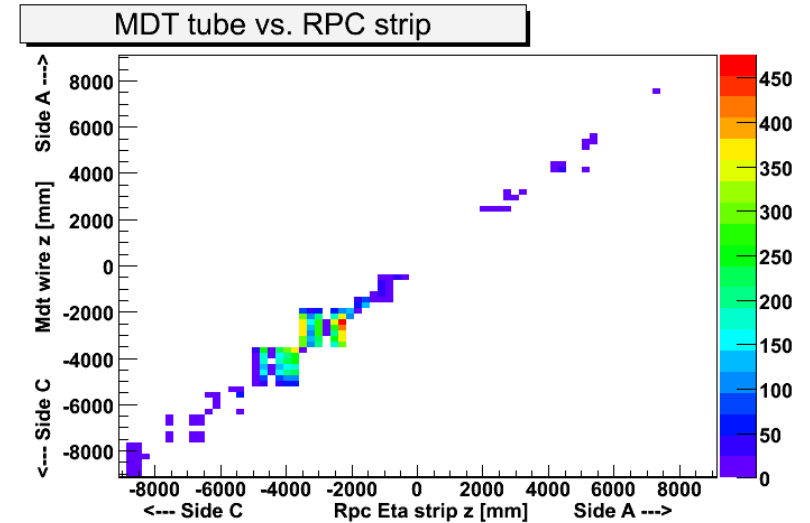

Angle correlation between ID and MS

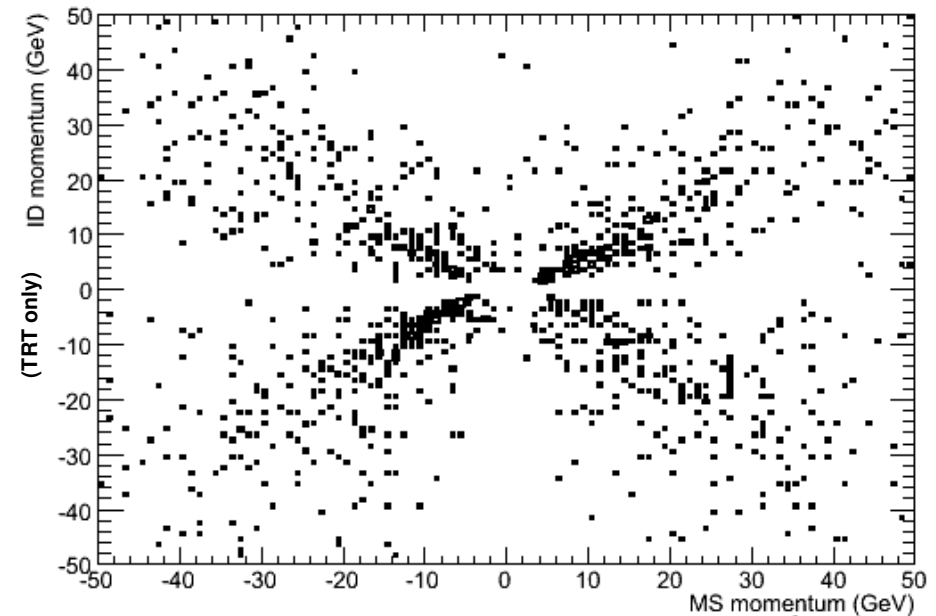

Track momentum correlation TRT and MS
'Wrong' sign for downward muons in upper side of the detector



Muons System Alignment

- **Goal:** 10% accuracy for a 1TeV muon track requires a resolution on the reconstructed sagitta of $50\mu\text{m}$. Intrinsic resolution of the muon chambers: $\sim 35\mu\text{m}$

- For needed sagitta accuracy: track-based alignment algorithms used in combination with optical system (~ 12000 optical sensors)

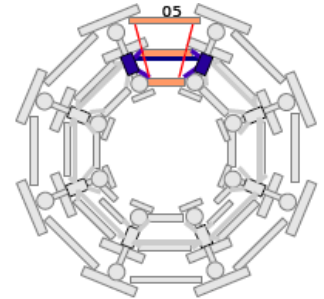

- **Geometer survey:** positioning accuracy of the 1200 MDT chambers: $\sim 5\text{mm}$
- Barrel alignment fit in sector 5 performed with cosmic events
- To achieve the desired $30\mu\text{m}$ accuracy for large and small sectors the track alignment algorithm needs about 100k of projective tracks with moment of 20 GeV.

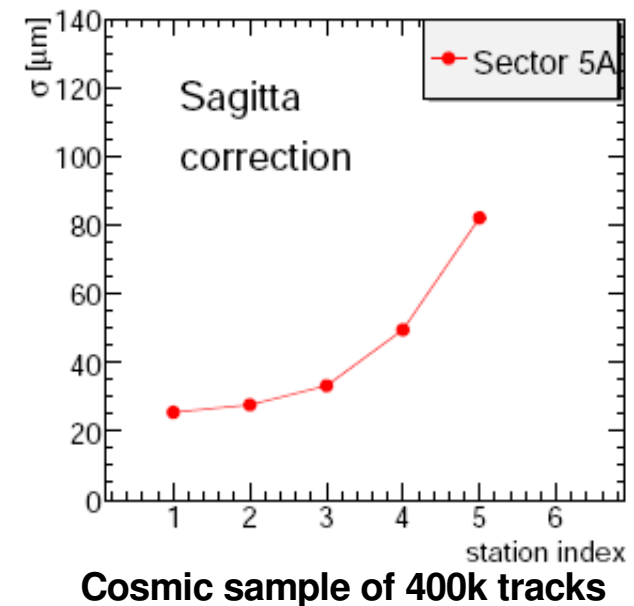
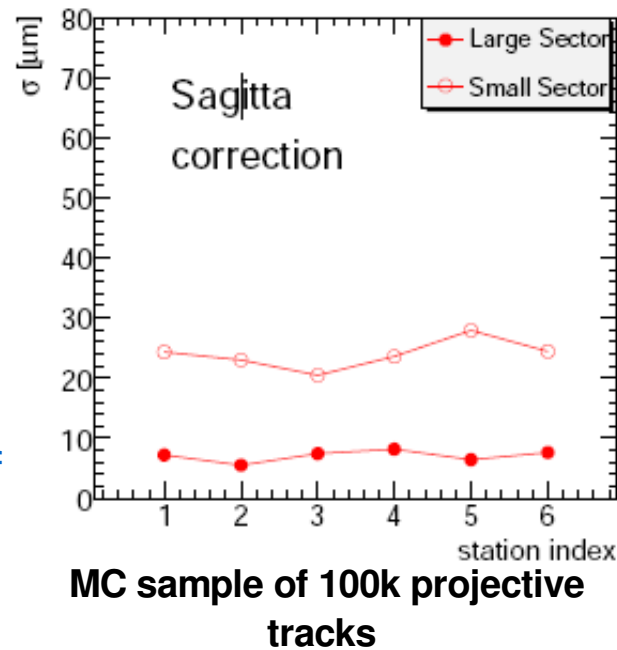



Atlas Remote Monitoring



• In 2008, after an initial period of experimentation, Atlas allowed the export of Point1 infrastructure to the outside network via NX server.

This allows the possibility of performing shifts from abroad for the systems interested in that.

- TileCal allowed the possibility of taking **remote Data Quality shifts** and the experience in 2008 was very positive.

It is particularly interesting for:

- People who cannot travel to CERN for commitments in their home institutes (e.g. Professors)
- People in a different time region, who can take CERN night shifts.

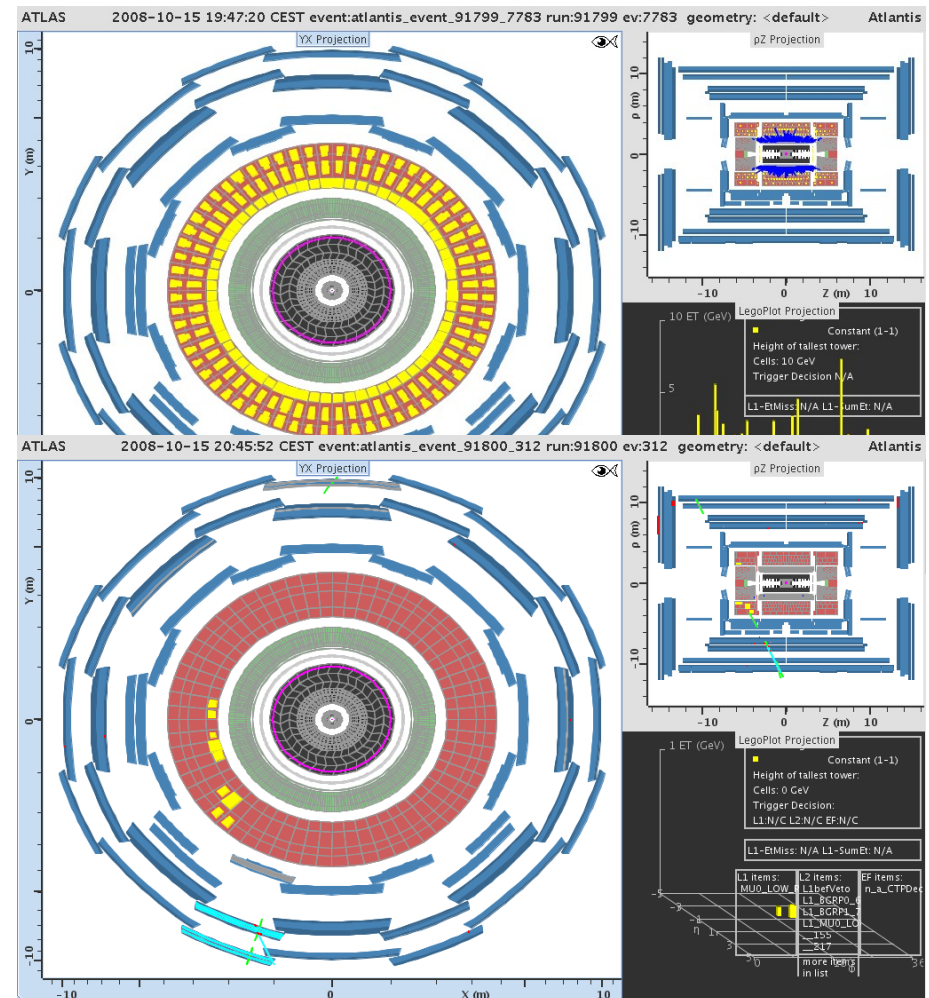



Atlas Remote Monitoring



Valencia TileCal group just finished to install in the lab a workstation for remote monitoring that can be used to take remote shifts

The screenshot shows the ATLAS TDAQ Software Graphical User Interface - Status Display. The interface is divided into several sections:

- Run Control:** Shows the RUN CONTROL STATE as **BOOTED**. It includes buttons for Shutdown, Boot, Terminate, Initialize, Unconfig, Config, Stop, Start, Pause, and Continue.
- Segment & Resource:** A tree view showing the status of various components, all marked as **BOOTED**. Components include TDAQpc-tdq-onl-19, Monitoringpc-tdq-onl-1, Pixel, SCT, TRT, BCM, ID, LArg, Tile, RPC, TGC, and MDT.
- Data Set Tags:** Shows the status of data set tags, including APPLICATION STATUS (UP), RUN CONTROL STATE (BOOTED), BUSY STATUS (FREE), and FAULT STATUS (OK).
- Run Parameter:** Shows the status of run parameters, including COMMAND (TERMINATE), Operational Monitoring (publish state, publish statistics), Debug Level Control (0), and Membership (IN).
- Log:** A scrollable log showing error messages: `igui_start STDERR: [10/16 17:31:48][CS.Commander.getDebugLevel] SEVERE: Cannot igui_start STDERR: [10/16 17:31:49][CS.Commander.getDebugLevel] SEVERE: Cannot igui_start STDERR: [10/16 17:31:49][CS.Commander.getDebugLevel] SEVERE: Cannot igui_start STDERR: [10/16 17:31:50][CS.Commander.getDebugLevel] SEVERE: Cannot igui_start STDERR: [10/16 17:31:50][CS.Commander.getDebugLevel] SEVERE: Cannot igui_start STDERR: [10/16 17:31:51][CS.Commander.getDebugLevel] SEVERE: Cannot`
- Recorded Events:** A table showing recorded events:

Time	Severity	Source	Message
17:31:45	WARNING	IGUI	INTERNAL SubscriptionNotFoundException while unsubscribing at IS server DF-L2SV-Segment-4-iss for subscription "L2SV"
17:31:45	WARNING	IGUI	INTERNAL SubscriptionNotFoundException while unsubscribing at IS server DF-L2SV-Segment-3-iss for subscription "L2SV"
17:31:35	WARNING	IGUI	INTERNAL SubscriptionNotFoundException while unsubscribing at IS server DF-L2SV-Segment-4-iss for subscription "L2SV"





Conclusions

- ATLAS has proved to be ready and in good shape for first beam data.
- Already 3 years of in-situ commissioning, but data has never been so useful for commissioning as first beam and recent cosmic data.
 - Most subsystems have joined the ATLAS combined cosmics runs. Latest system was pixels joining less than 2 months ago.
 - Essentially the entire detector has been fully tested with calibration and cosmic runs.
- ATLAS benefited only of 2 days of beam data in 2008 before LHC incidents stopped the beam commissioning program.
 - Even so, beam data was very useful for the commissioning of the detector
 - We look forward for first collisions in spring 2009.
- Current Priority is to establish initial calibration constants for early running
 - Already available preliminary alignments, energy scale calibrations and timing from both cosmics and first beam.